

advanced FLOW engineering Dynamic Air Scoop (DAS) Snorkel

Instruction Manual P/N: 55-21001

Make: Jeep	Model: Wrangler JL	Year: 2020-2025	Engine: L4-2.0L (t)
Make: Jeep	Model: Wrangler JL	Year: 2018-2025	Engine: L4-2.0L (t) Hybrid
Make: Jeep	Model: Wrangler JL	Year: 2018-2025	Engine: V6-3.6L
Make: Jeep	Model: Wrangler JL	Year: 2020-2023	Engine: V6-3.6L Hybrid
Make: Jeep	Model: Gladiator JT	Year: 2020-2025	Engine: V6-3.6L



- Please read the entire instruction manual before proceeding.
- Ensure all components listed are present.
- For technical support please call 951-493-7185.
- Ensure you have all necessary tools before proceeding.
- Do not attempt to work on your vehicle when the engine is hot.
- Retain factory parts for future use.

Label	Qty.	Description	Part Number
A	1	Tube, Rotomold Riser: 55-21001	05-5521001B1
B	1	Tube, Rotomold Runner: 55-21001	05-5521001B2
C	1	Tube, Rotomold Adapter: 55-21001	05-5521001B3
D	1	Coupling, Silicone Reducer (5" x 4.68") ID x 1.5" L	05-01784
E	1	Coupling, Silicone Elbow Rdr (4.20"x3.50") 66 Deg	05-01785
F	1	Bezel, Snorkel: 5.25" x 3.25", Black	05-01804B
G	1	Grille, Snorkel: Hex, 5.25" x 3.25", Black	05-01803
H	1	Clamp, 080 (3-1/2" - 5-1/2")	03-50011
J	1	Clamp, 072 (3" - 5")	03-50010
K	1	Clamp, 064 (3-9/16" - 4-1/2")	03-50006
M	1	Clamp, 056 (3-1/16" - 4 ")	03-50009
N	4	Screw, Btn Hd Socket: M6x1x12	03-50102
P	1	Plug, Sil: 0.69" Dia w/ Tab	03-50766
Q	2	Washers, Flat: M10 (Not shown)	03-50470

Installation will require the following tools:

Phillips and standard screw drivers, 8mm nut driver, 10mm sockets and driver, T-40 Torx Bit, 4mm Allen Bit, panel removal tool, 11mm open end wrench, hand saw, and file or sandpaper. Optional: Silicone.

Emissions Disclaimer: This product does not require a CARB EO#

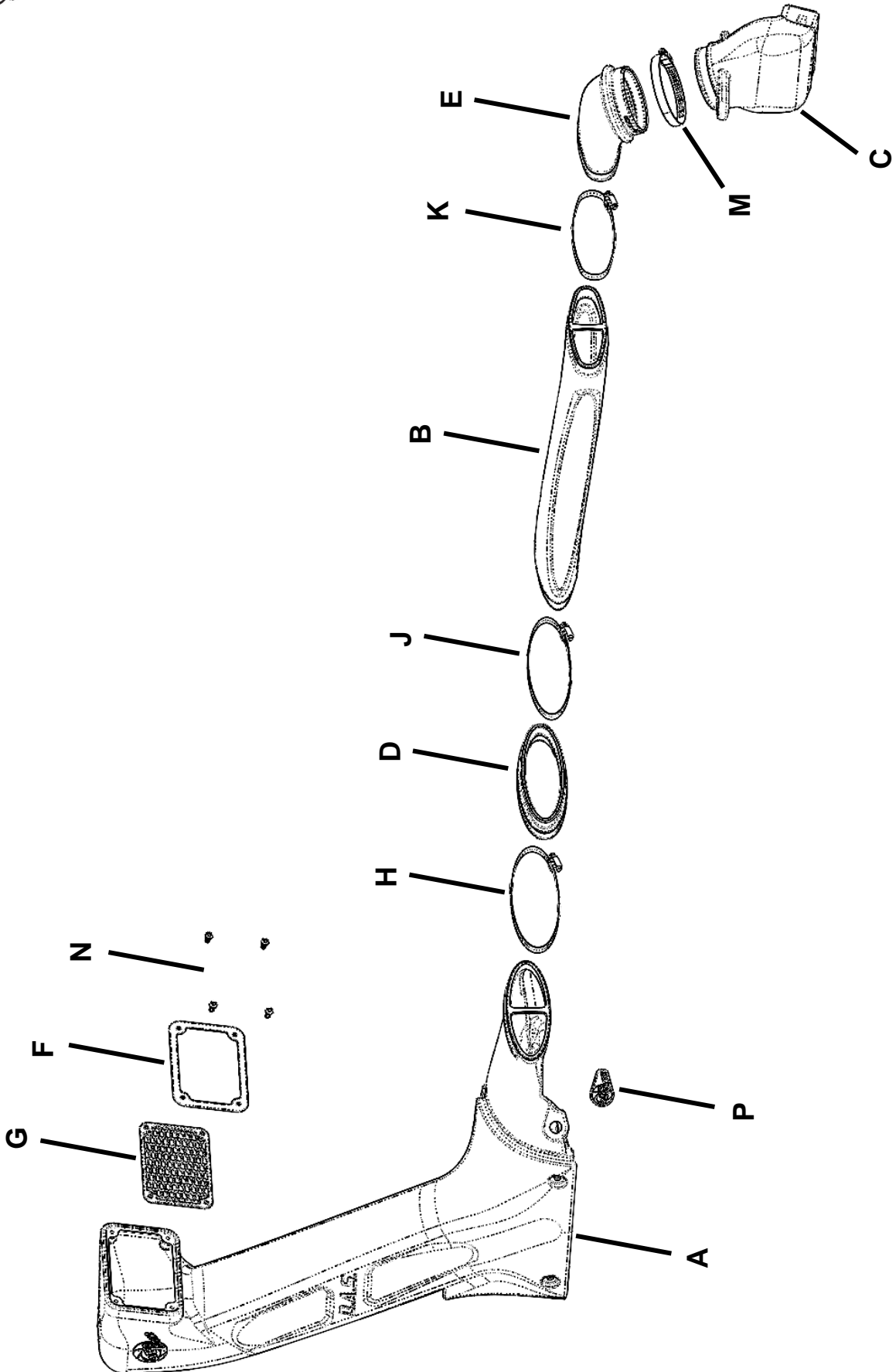



Figure A

Refer to Figure A for Steps 1-3

Step 1: Open the hood and fold it all the way back onto the windshield. Make sure to place a soft cloth between the hood and the windshield. Disconnect hood struts if equipped.

Step 2: Use a trim removal tool to remove the foam insulation from both the driver's side and passenger's side of the cowl area. There is one push clip holding each foam section in place. ①

Step 3: Remove the hood trim seal from the cowl support by pulling straight upward on it. ②

Note: The following photos were taken on a 2020 Jeep Wrangler L4-2.0L (t). Please note that the engine bay may look different than yours.

**Figure B****Refer to Figure B for Steps 4-6**

Step 4: Use a trim removal tool to remove the five (5) push clips from the top of the cowl support. (3)

Step 5: Use a 10mm socket and driver to remove the five (5) bolts from the cowl support. (4)

Step 6: Remove the cowl support from the vehicle. (5)

**Figure C****Refer to Figure C for Steps 7-8**

Step 7: Use a high contrast marker to mark out the area shown above to be cutout from the passenger's side of the cowl support.

Step 8: Use a hand saw to cut along the marked lines as shown. The plastic can be sanded down as needed to make a smooth surface after cutting is complete.

**Figure D****Refer to Figure D for Steps 9-11**

Step 9: Reinstall the cowl support and secure it into place using the five (5) push clips and five (5) bolts removed previously. (6)

Step 10: Reinstall the foam insulation on the driver's side of the cowl area. (7)

Step 11: Reinstall the trim seal onto the cowl support. (8)

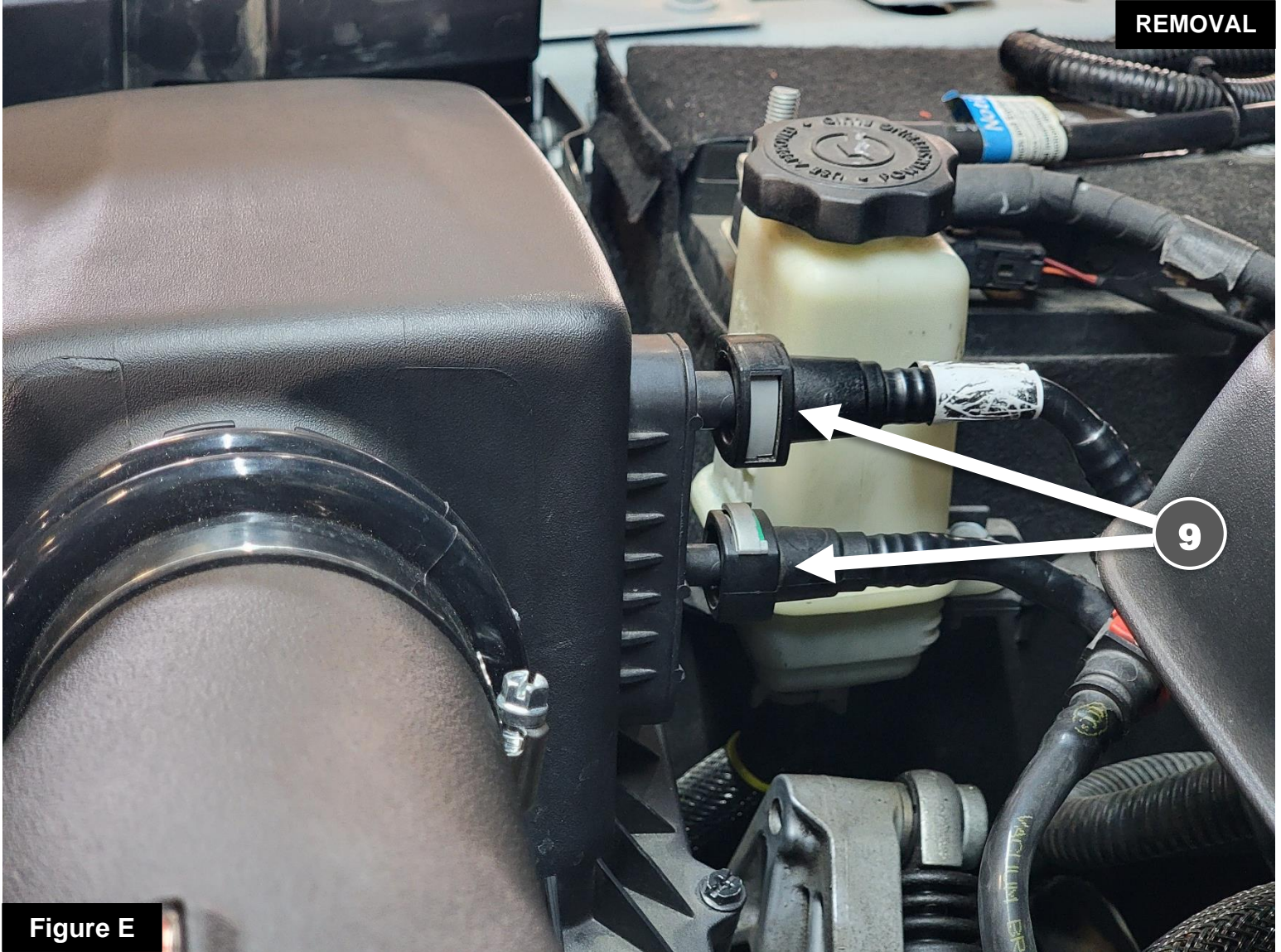
**Figure E****Refer to Figure E for Step 12****Note: For 2018-2023 vehicles with the L4-2.0L (t) engine only.**

Step 12: Unclip the two hard lines connected to the top of the intake housing by pushing the grey plastic tab inward and simultaneously pulling the tube backwards. ⑨

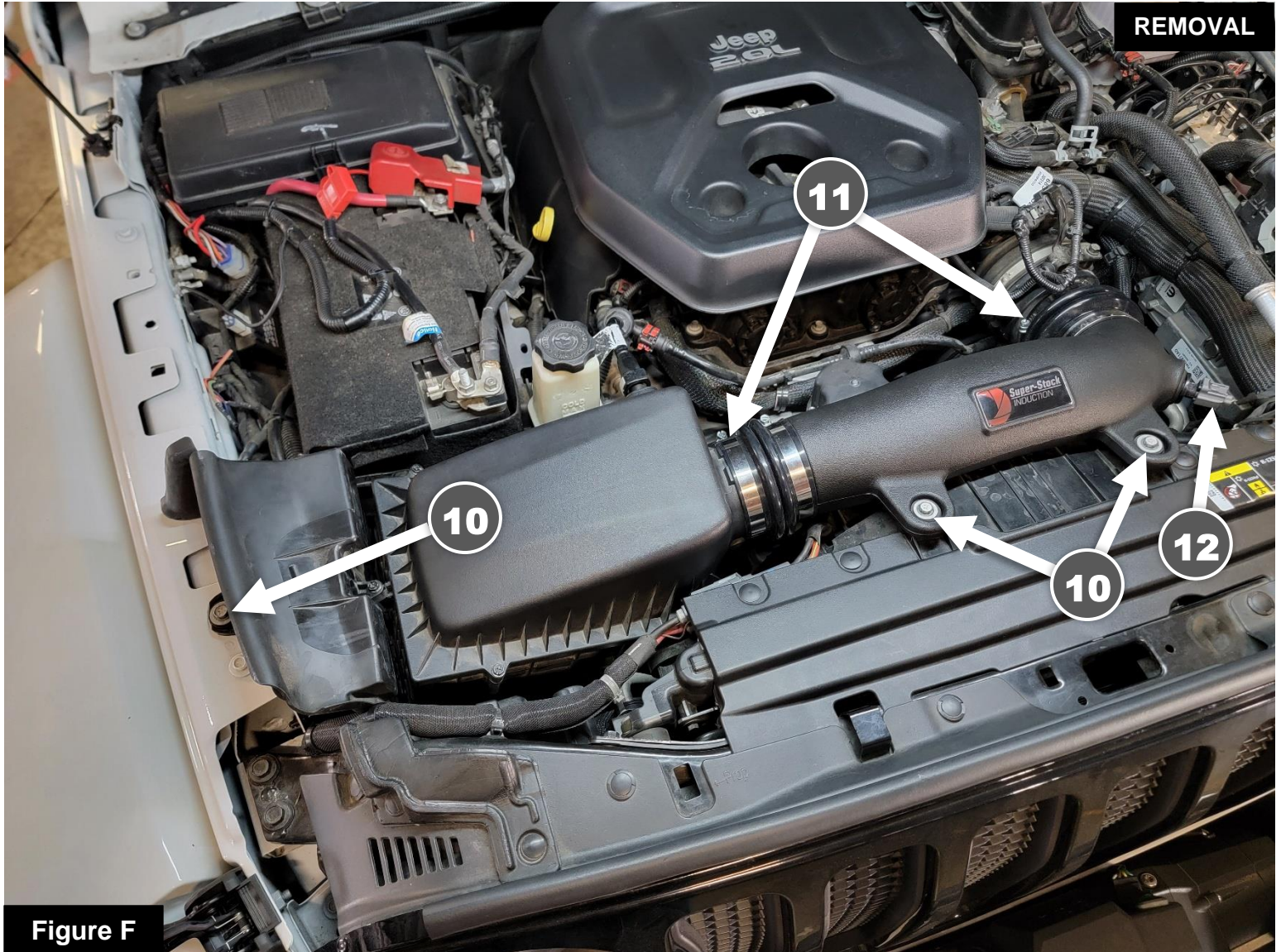

Figure F

Refer to Figure F for Steps 13-18

Step 13: Remove the three (3) bolts using a 10mm socket and driver. (10)

Step 14: Loosen the two (2) clamps at the air box and turbo inlet (or throttle body). (11)

Step 15: **For all V6-3.6L**, remove the CCV connection from the intake tube by pushing the grey plastic tab inward and simultaneously pulling the tube backwards (not shown).

Step 16: **For 2024+ L4-2.0L (t)**, remove the two (2) plastic tubes by pushing the grey plastic tabs inward and simultaneously pulling each tube backwards (not shown).

Step 17: Disconnect the air temperature sensor from the intake tube. (12)

Step 18: Remove the intake tube from the vehicle, then remove the intake housing by pulling it straight upwards. Make sure the grommets stay in place on the housing mounting plate.

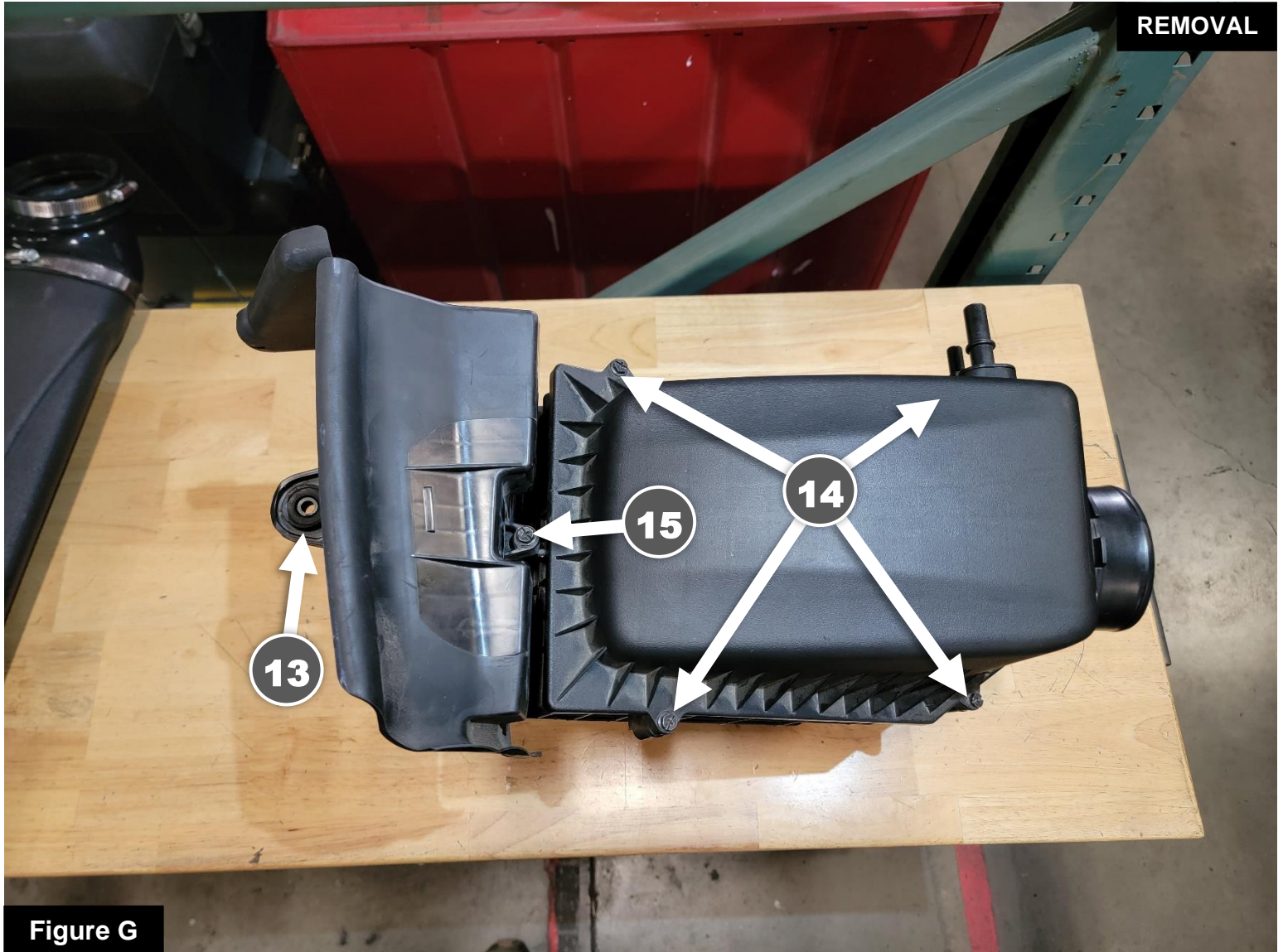
**Figure G****Refer to Figure G for Steps 19-22**

Step 19: Remove the metal sleeve and grommet from the stock intake inlet. (13)

Step 20: Use an 8mm socket or a Phillips screwdriver to remove the top of the air box from the lower half of the air box. (14)

Step 21: Remove the air filter from the bottom of the air box.

Step 22: Remove the screw securing the stock air inlet to the intake housing using a 10mm socket or Phillips screwdriver. (15)

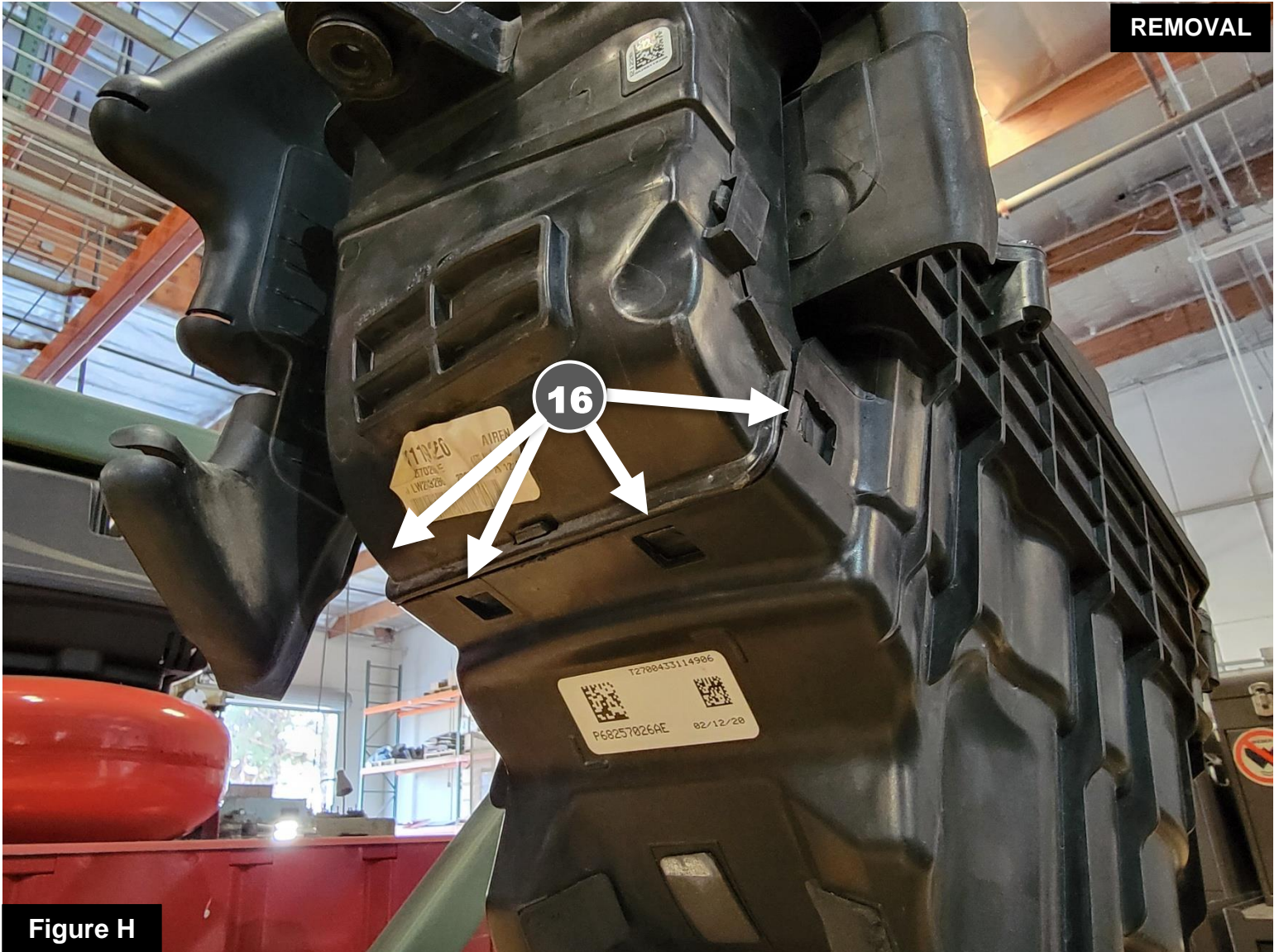
**Figure H****Refer to Figure H for Step 23**

Step 23: Disconnect the stock air inlet from the intake housing using a slim plastic trim removal tool (or similar). Carefully work your way around the air inlet and be sure not to break any of the clips on the stock intake housing. ①6

**Figure I****Refer to Figure I for Step 24-27**

IMPORTANT NOTE!!! To make the snorkel watertight, add a silicone sealant to the entire interface between the aFe POWER air inlet and the factory air box. Allow for proper time to dry before handling the components. The drains at the mounting pegs would also need to be sealed up, and a drain with a valve would need to be added to allow for proper sealing and draining (not included).

Step 24: Install the new aFe POWER air inlet to the airbox and secure it using the factory screw and an 8mm socket or Phillips screwdriver. (17)

Step 25: Reinstall the air filter into the lower half of the airbox.

Step 26: Reinstall the top of the air box using the factory screws and an 8mm socket or Phillips screwdriver.

Step 27: Install the rubber grommet and metal sleeve into the mounting tab on the aFe POWER air inlet. (18)

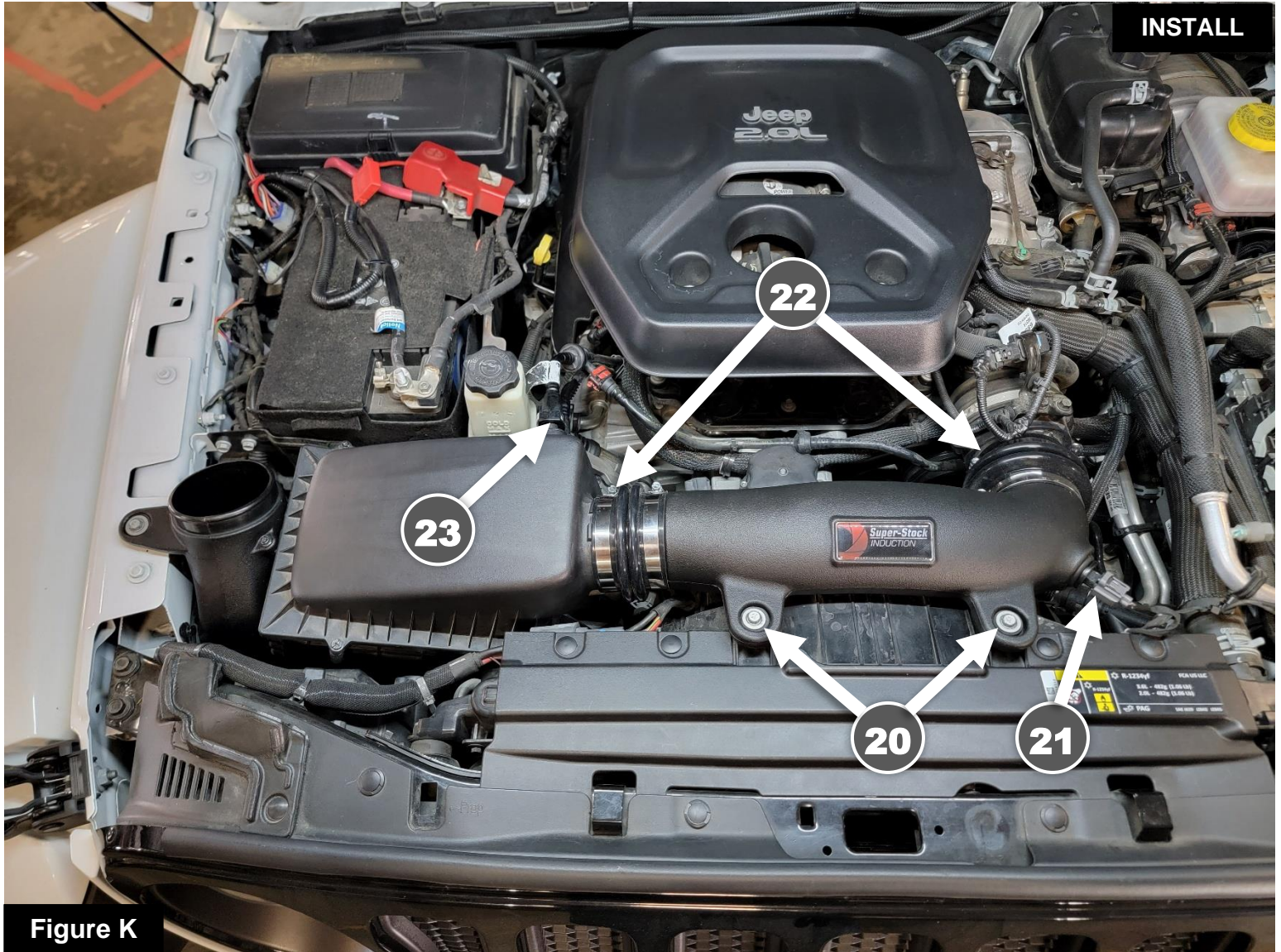

Figure J

Refer to Figure J for Steps 28-29

Step 28: Reinstall the air box and aFe POWER inlet assembly back into the vehicle.

Step 29: Secure the air box with the stock screw using a 10mm socket and driver. (19)



INSTALL

Figure K

Refer to Figure K for Steps 30-33

Step 30: Reinstall the intake tube into the vehicle and secure it in place with the two (2) bolts using a 10mm socket and driver. (20)

Step 31: Reconnect the air temperature sensor connector to the tube. (21)

Step 32: Tighten the two (2) clamps at the air box and the turbo inlet (or throttle body). (22)

Step 33: Reconnect any hard lines to the intake tube or housing that were disconnected previously. (23)

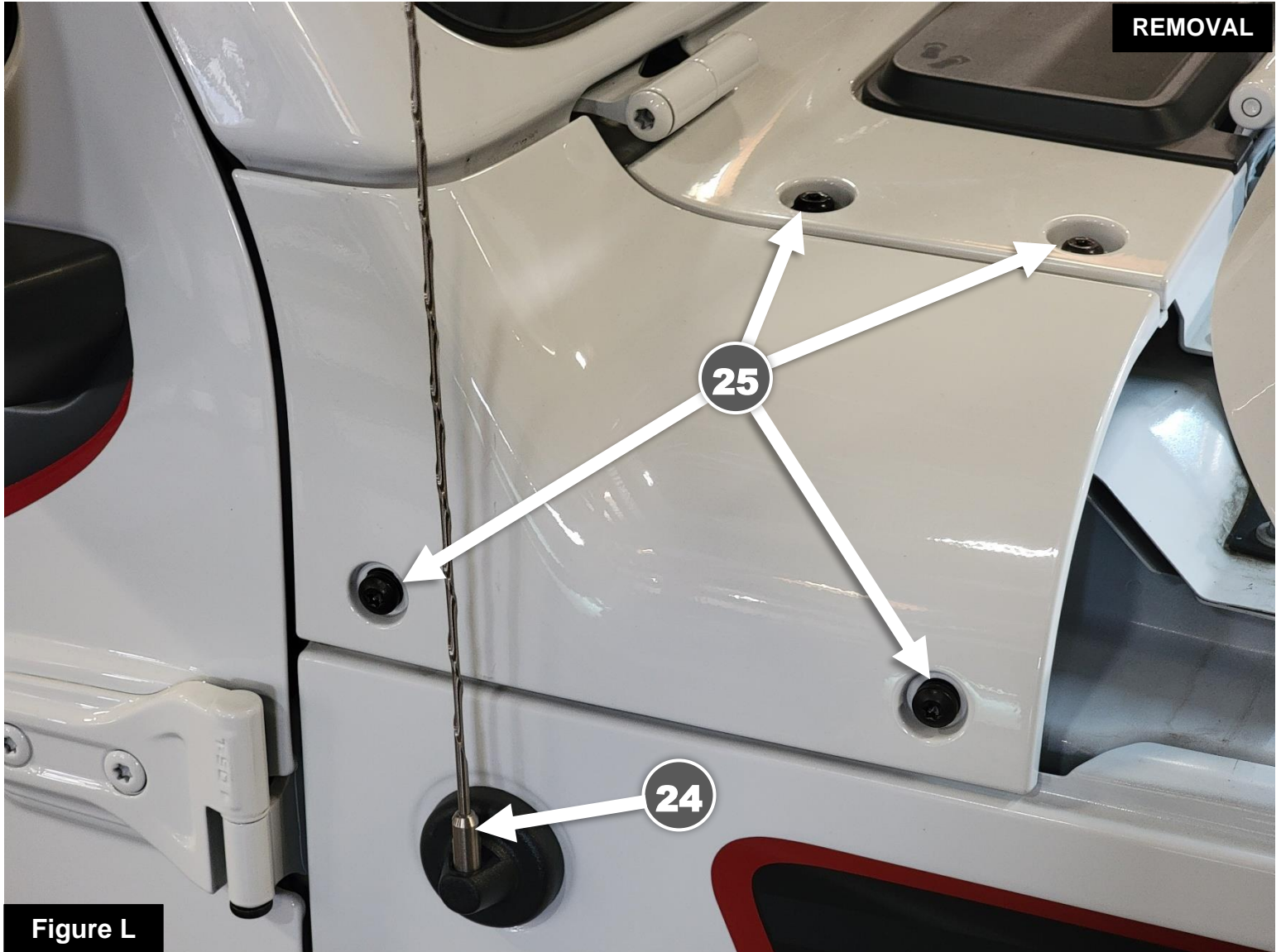

Figure L

Refer to Figure L for Step 34-36

Step 34: Tilt the hood forward and rest it on its prop rod (or reconnect hood struts if equipped).

Step 35: **2018-2023 vehicles only**, using an 11mm open end wrench, remove the stock antenna from the vehicle. (24)

Step 36: Using a T40 Torx bit, remove the four (4) screws from the cowl cover and remove the cover. (25)

**Figure M**

Refer to Figure M for Steps 37-38

Step 37: Clean up any dirt and debris from behind the cowl cover to prepare for the snorkel install.

Step 38: The windshield drain hose can get stiff on older vehicles. If the hose gets in the way of the installation, it can be trimmed back as needed. (26)

**Figure N****Refer to Figure N for Step 39**

Step 39: Install the grille and bezel into place on the aFe POWER snorkel and secure them into place using the (4) four stainless steel screws provided. Tighten using a 4mm allen wrench, and do not overtighten.

②⑦

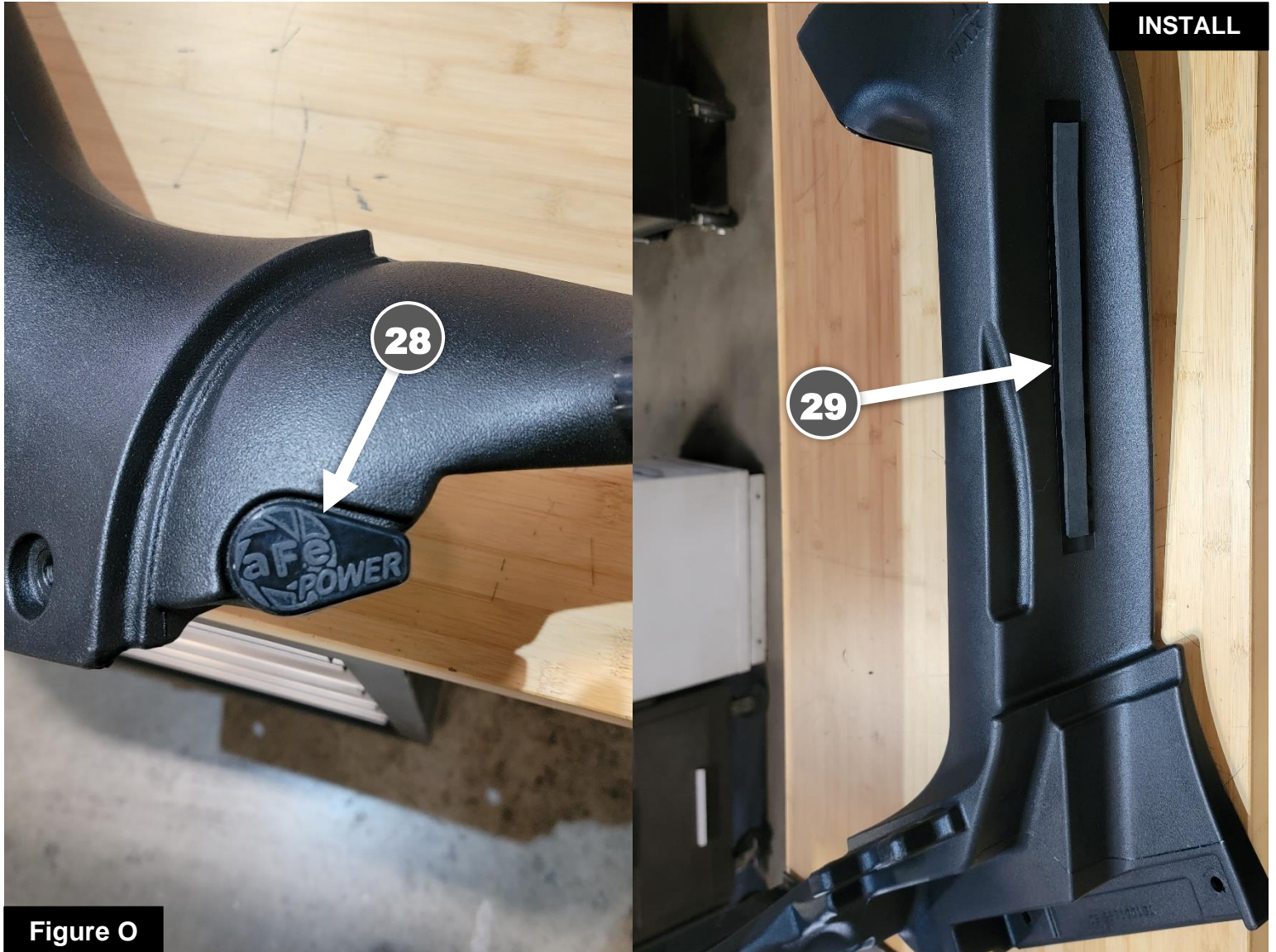

Figure O

Refer to Figure O for Steps 40-41

Step 40: Install the silicone drain plug into the hole on the bottom of the snorkel as shown. (28)

Step 41: Verify that the foam strip is properly installed on the back of the snorkel riser section as shown. (29)

Note: The plug can be used to seal up the snorkel during water crossings as needed. During normal driving where you may experience frequent heavy rainfall, the plug can be removed to allow the drainage of any water that may enter the grille.



Refer to Figure P for Steps 42-44

Step 42: Install the aFe POWER snorkel by sliding it straight in from the side of the vehicle. (30)

Step 43: Secure the snorkel using the factory hardware. If the snorkel feels loose with the factory screws tightened, place the thicker washers under the screws on the upper cowl side as needed. (31)

Step 44: **2018-2023 vehicles only**, Reinstall the antenna and tighten with an 11mm open end wrench. (32)

**Figure Q****Refer to Figure Q for Step 11**

IMPORTANT NOTE!!! To make the snorkel watertight, add a silicone sealant to the entire interface between the aFe POWER tube and couplers. Allow for proper time to dry before handling the components.

Step 45: Assemble the runner tube section with the couplers and clamps preinstalled as shown. Notice the part number on the tube is facing upward in this photo. Clamps will need to be installed on the bottom, so they do not interfere with the hood liner. (33)

Step 46: It may help to preshape the clamps into an elliptical shape before installing them onto the couplers.

Step 47: Tighten the two clamps at the intake tube and leave the other two clamps loose for now. (34)

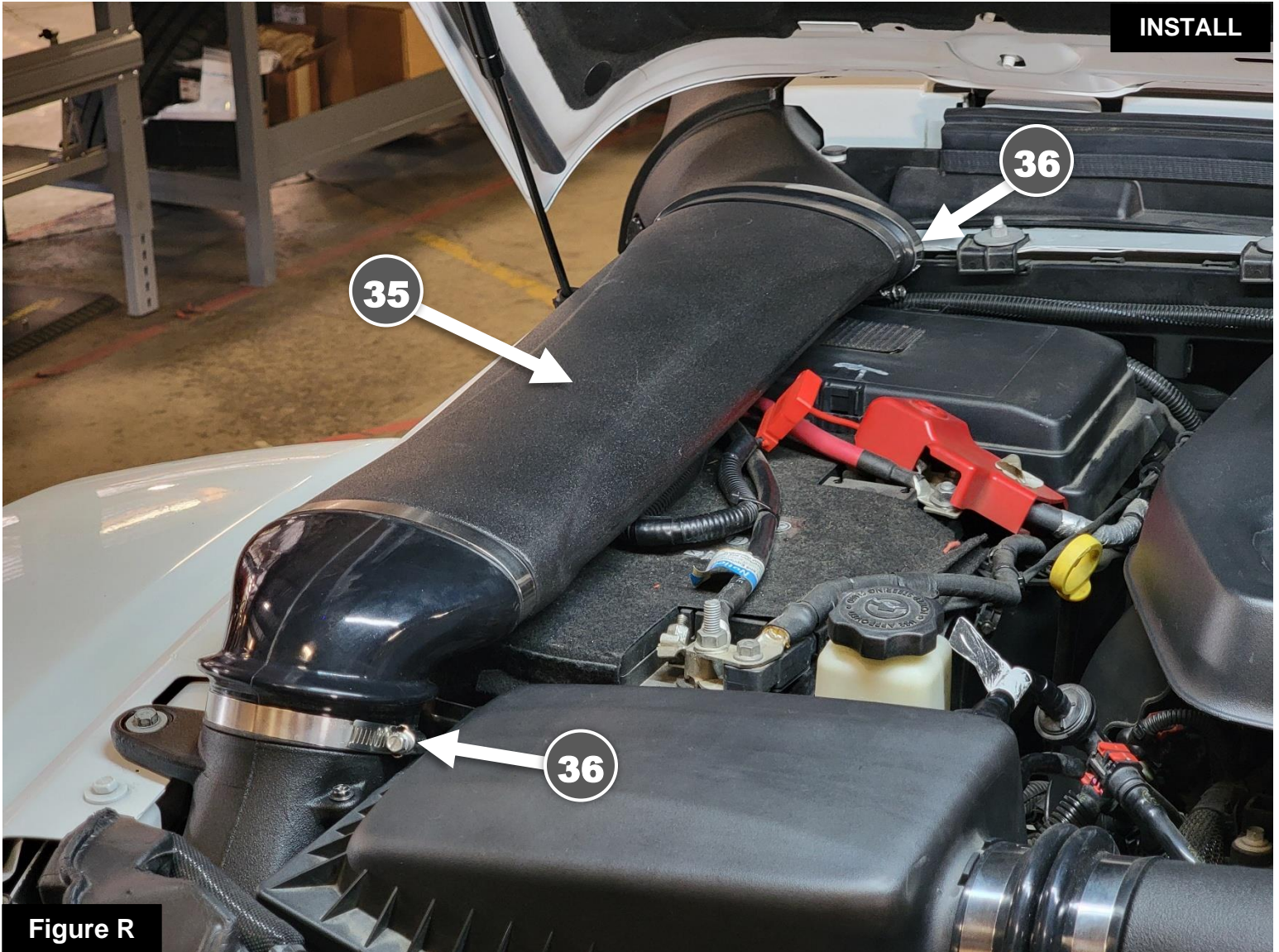
**Figure R****Refer to Figure R for Steps 48-49**

IMPORTANT NOTE!!! To make the snorkel watertight, add a silicone sealant to the entire interface between the aFe POWER couplers and mating components. Allow for proper time to dry before handling the components.

Step 48: Install the runner tube section with couplers and clamps into the vehicle as shown. (35)

Step 49: Tighten the remaining (2) two clamps at the riser section and the air inlet. (36)

Optional: If the intent of installing the snorkel is for clean air only, and serviceability is favored over watertight seal, then the clamp at the riser and the clamp at the air inlet (36) can be omitted. This will allow for quick access to the fuse box and/or battery.



Figure S

Refer to Figure S for Step 50

Step 50: Verify everything is tight and all connections are reattached at this time.



Figure T

Refer to Figure T for Steps 51-52

Step 51: Close the hood and verify that there is no interference between the snorkel and the hood liner.

Step 52: Your installation is now complete!



advanced FLOW engineering, inc.

Corona, CA 92879

<https://afepower.com/contact>

P/N: 55-21001