



**DOWNLOAD THE LATEST
INSTALL MANUALS AT
www.bddiesel.com**



BD Dodge Cummins Cab&Chassis Exhaust Manifold

| | |
|----------------|--|
| 1045967 | 2007.5-2012 Dodge 6.7L Cab&Chassis |
| 1046067 | 2007.5-2012 Dodge 6.7L Cab&Chassis Complete Kit |

Please read all instructions before installation

| Common Kit Contents – 1045967 & 1046067 | | |
|---|--|---|
| Manifold | 1453149 | 1462431 |
|  |  |  |
| Manifold Qty: 1 | Fitting; 1/8NPT to Port Qty: 1 | Stud; M10-1.5 Short Qty: 2 |
| 1462430 | 1200208 | 1462441 |
|  |  |  |
| Stud; M10-1.5 Long Qty: 3 | Plug; 1/8" NPT Hex Qty: 2 | Nut; M10-1.5 Qty: 9 |





| Additional Kit Contents – 1046067 Only** | | | |
|---|--|---|-----------------------------|
| 1405900 | 1405902 | 5260648 | |
|  |  |  | |
| Manifold Gasket 6-Pack Qty: 1 | EGR Gasket Qty: 1 | Turbo Gasket Qty: 1 | |
| 1405937 | FK-1045982 | | |
|  |  | | |
| Bolt Spacers Qty: 12 | M10x60 Qty: 12 | M10x35 Qty: 2 | M10 Washer Qty: 2 |

Table of Contents

- Kit Contents 2
- Table of Contents..... 3
- Installation..... 3
 - Removal 3
 - Installation 9

Installation

Disconnect both vehicle batteries before installation for safety, drain coolant and setup on a hoist.

Removal

1. Remove the intake housing bolt (1).

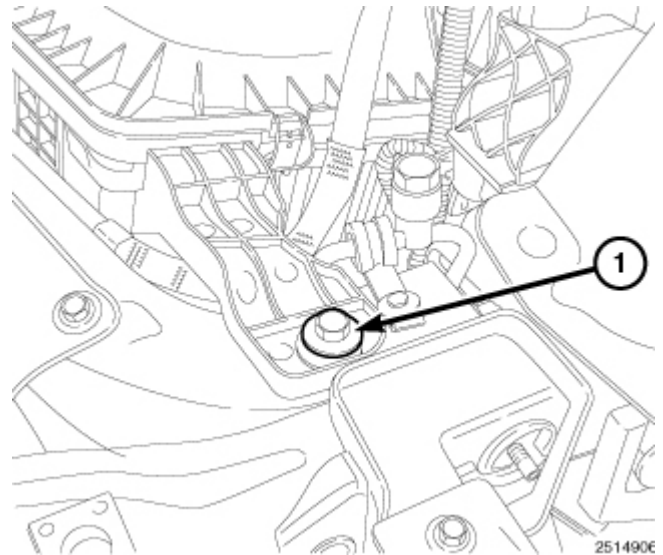

2. Disconnect the Mass Air Flow (MAF) (3) sensor.
3. Disconnect the TBAP (2) sensor.
4. Loosen clamp (4) and disconnect the intake air tube (5) from the air cleaner body (1).
5. List and remove air cleaner body (1).

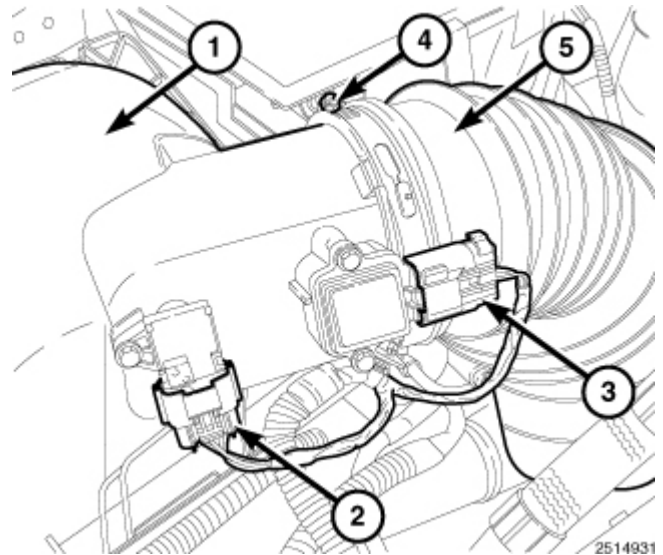

6. Disconnect the breather hose (3).
7. Loosen the clamp (1) and remove the outlet (2) tube from turbocharger.

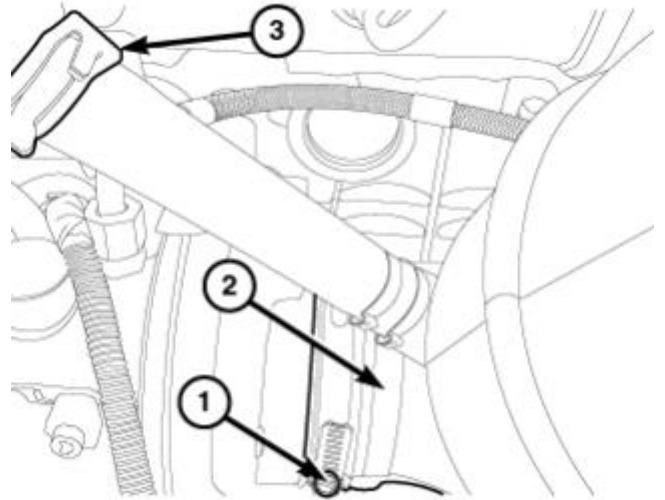

2423891

8. Remove the four bolts (1) and the engine cover (2).

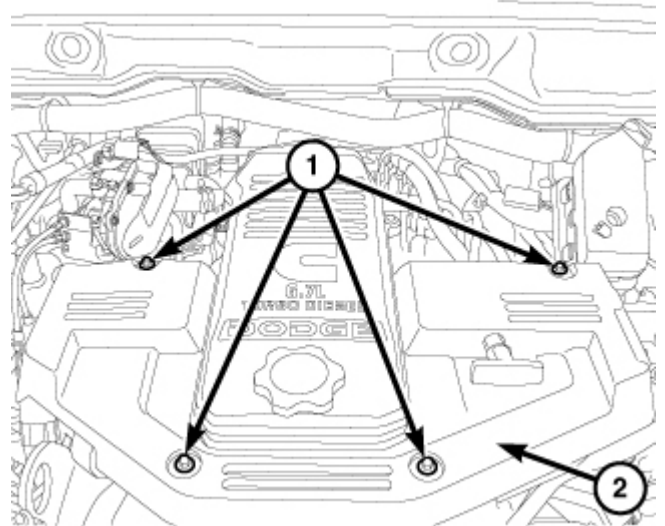

2423158

9. Disconnect EGR Temperature sensor harness connector (4).
10. Loosen and remove the two clamps (1) and (3) at ends of the EGR crossover Tube.
11. Remove the "P" clamp mounting bolt (5) at center of EGR Crossover tube.
12. Remove the EGR crossover Tube (2).

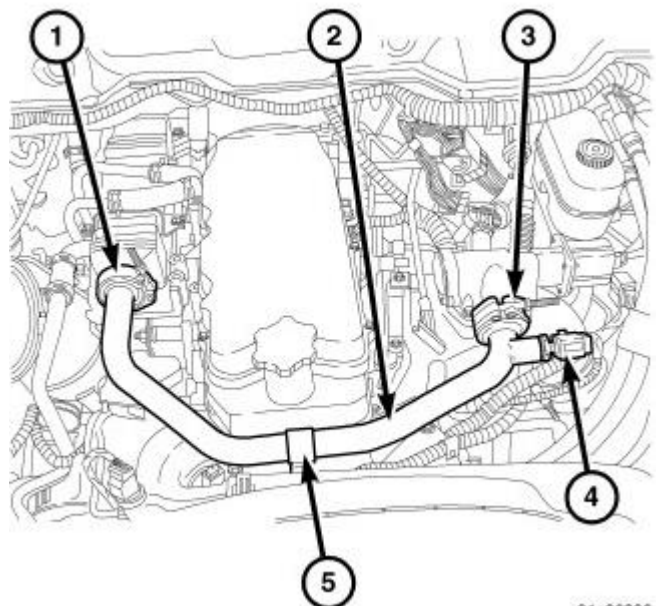

81a96966

13. If equipped, remove the retaining nut and position aside the transmission fill tube from the EGR cooler.

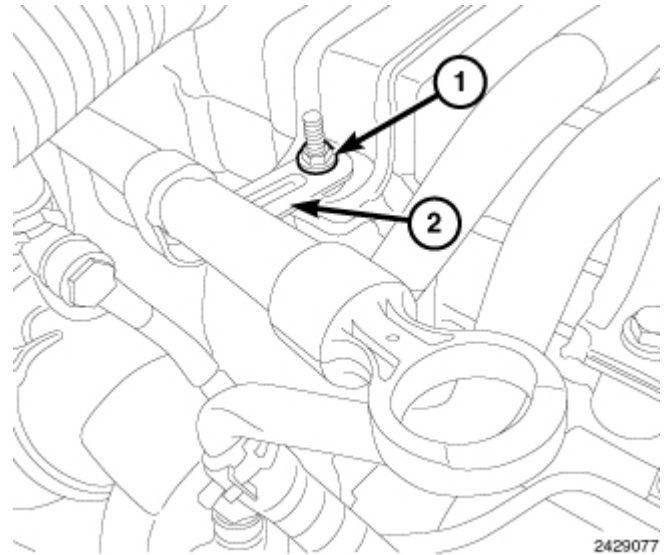

14. As illustrated, using a suitable pair of channel lock pliers, remove the forward coolant tube (2) from EGR cooler.

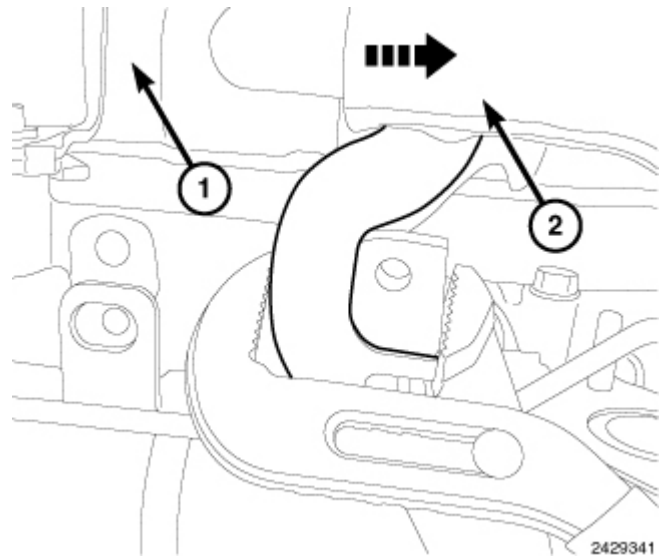

15. Disconnect breather hose (1), remove the bolt (3), and remove the breather tube (2)

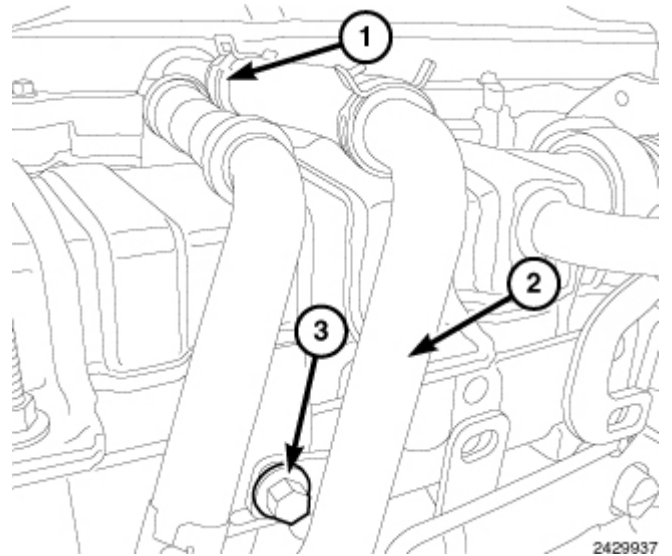

16. Remove the bolt (2) and remove the rear coolant tube from connection (1) and (4).
17. Remove the EGR cooler mount bolts (3).

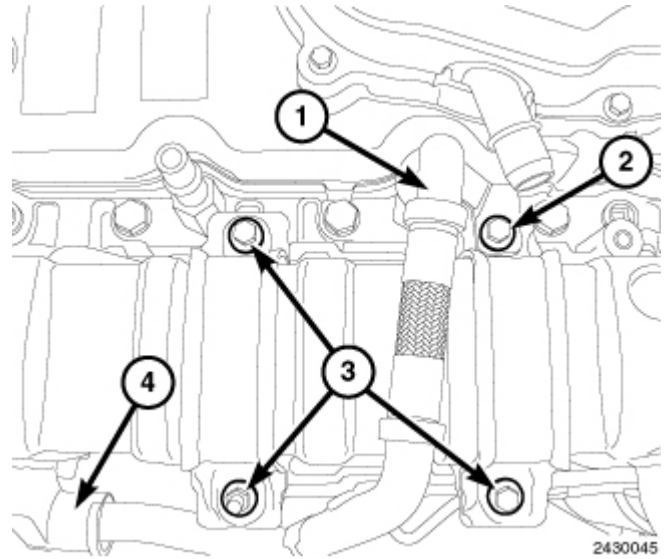

18. Remove the EGR cooler flange nuts (1).
19. Remove the EFR cooler.
20. If required, remove the EGR cooler mounting support.

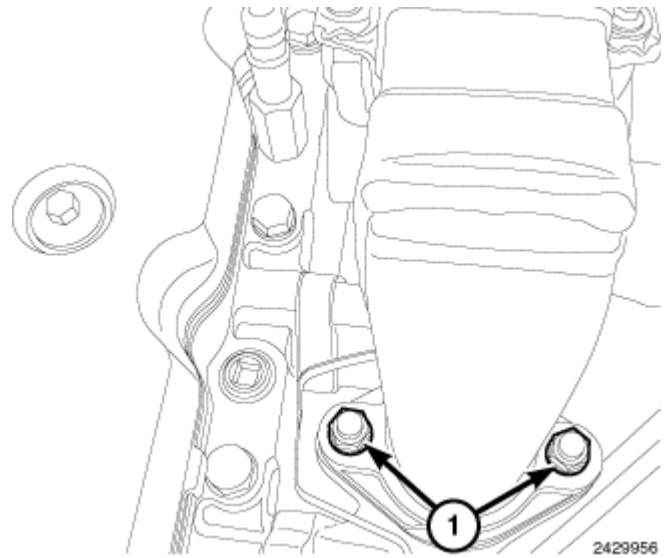

21. Remove the delta-P line bracket cap-screw nuts and remove the delta-P line from the exhaust manifold and thermostat housing.
22. Remove the heat shield and noise panel (if equipped) from the exhaust manifold

23. Loosen the clamp (1) and remove the charge air tube (2) from the turbocharger outlet.

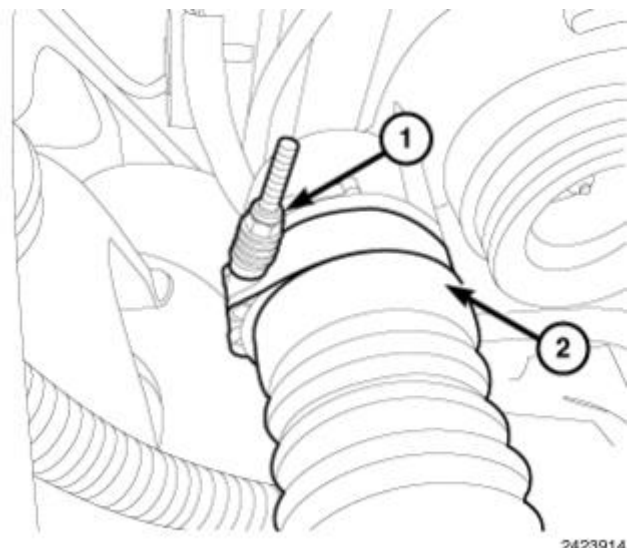

- 24. Disconnect the turbocharger speed sensor wire harness connector.
- 25. Disconnect the turbocharger actuator wire harness connector.
- 26. Remove the turbocharger oil pressure line (3).
- 27. Remove the turbocharger coolant lines at engine block and turbocharger.

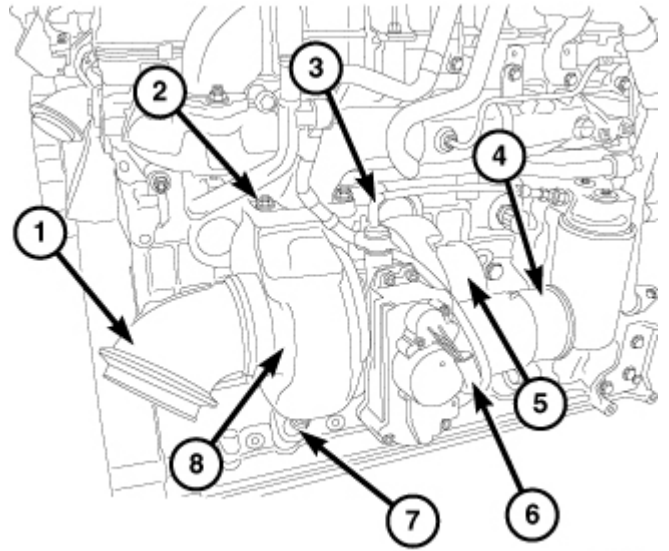

1283861

- 28. Remove the right-side wheelhouse splash shield.
- 29. Install the engine support fixture tool 8434B.
- 30. Remove the right-hand side engine mount. (NOTE: engine mount does not need to fully removed, just repositioned).

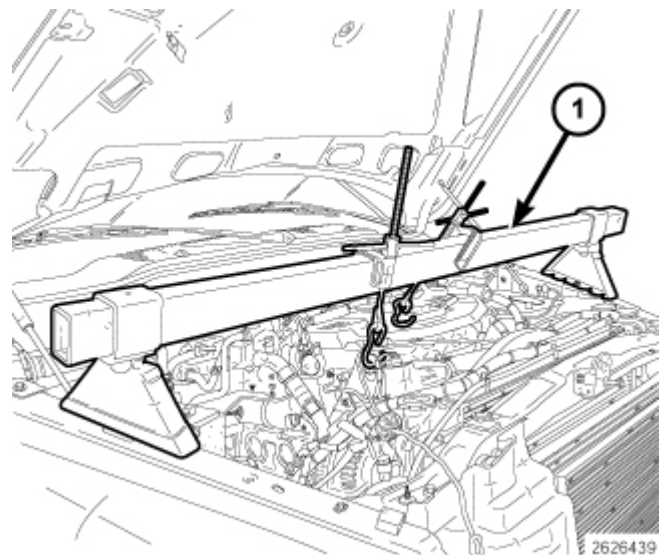

2626439

- 31. Raise and support the vehicle.
- 32. Remove the exhaust steady rest bracket from transmission.
- 33. Remove the V-band clamp (1) from the turbocharger exhaust outlet.

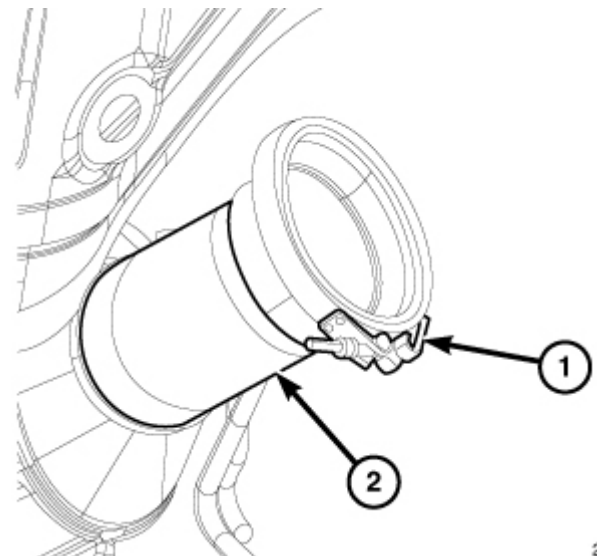

2592481

34. Remove the turbocharger drain tube (2) from the turbocharger and cylinder block.
35. Lower the vehicle.
36. Remove and position aside the grid heater relay from battery tray.
37. Using Tool 9866, remove the turbocharger to exhaust manifold mounting nuts.
38. Remove the turbocharger from the vehicle by lifting from top of the engine compartment.

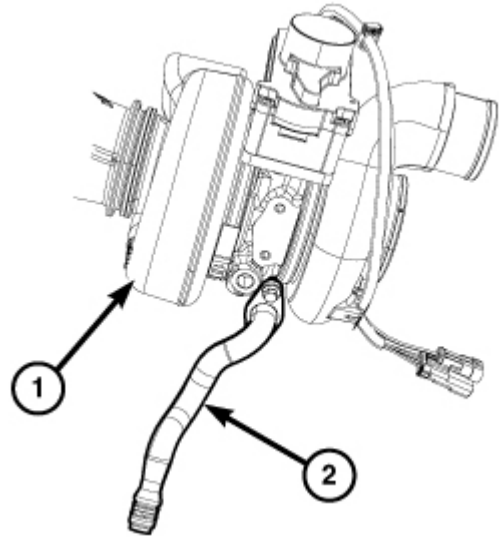

2595525

39. Remove the two (2) rear exhaust manifold cap-screw lock plates.
40. Remove the Cab heater tubing/bracket from the exhaust manifold stud.
41. Remove the exhaust manifold.

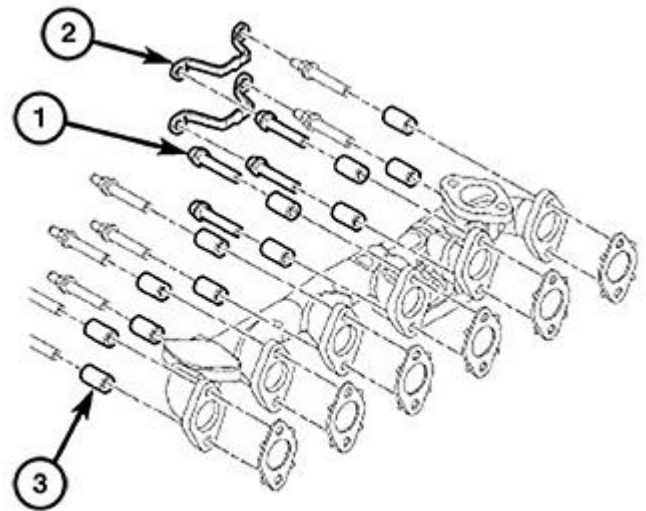

81af5a81

Installation

1. Referring to the following picture to know the location of studs and fittings on in respect to the manifold.

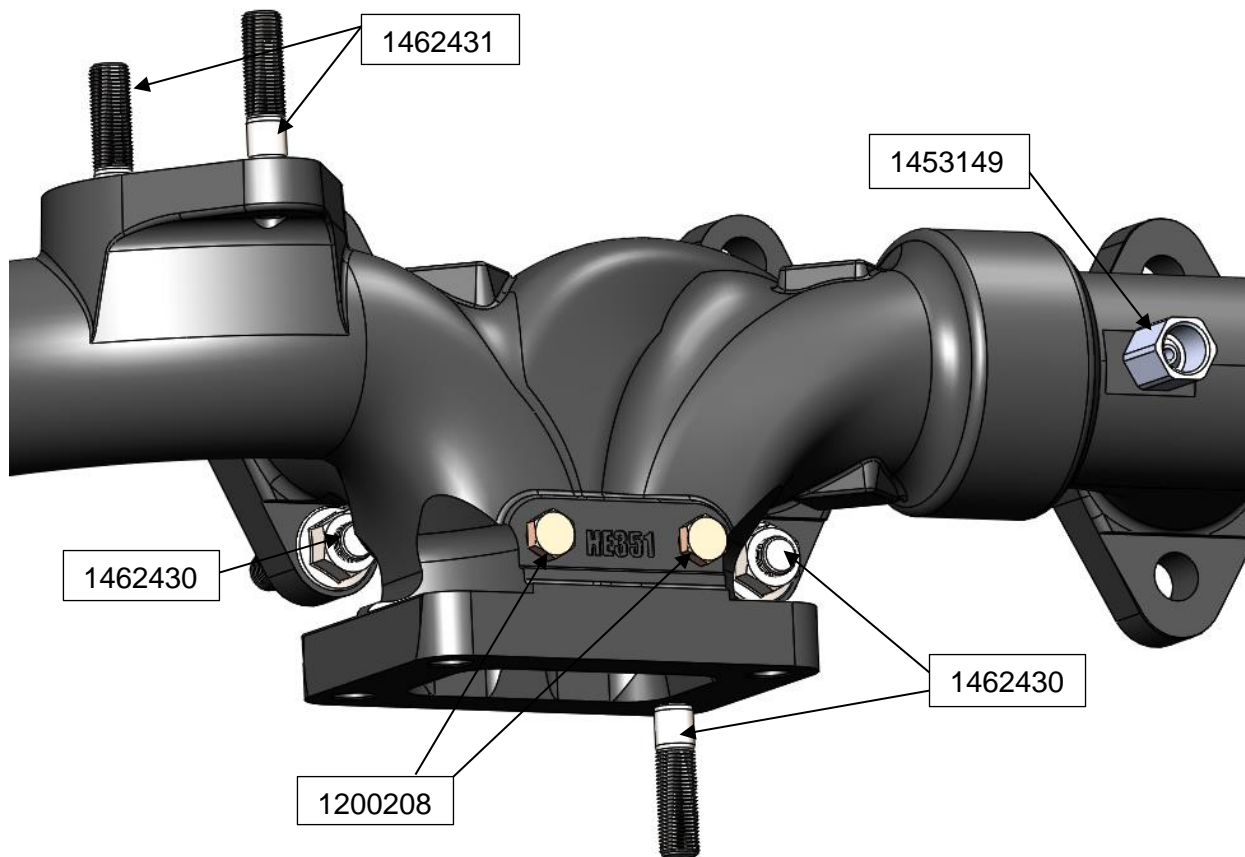

2. Clean the cylinder head exhaust port gasket surfaces.
3. Clean the turbo mounting flange on the turbocharger.
4. Install exhaust manifold with one factory bolts and the 1462430 studs to hold in place
5. Using the supplied studs, insert studs at the lower mount of exhaust of cylinders 4 and 5. Lift the manifold into place and use these studs as support. Don't forget to install gaskets.
6. Insert a factory bolt at the lower threaded mount of cylinder 2 with gasket. Keep this bolt loose.
7. Use the supplied M10 nuts on the stud installed earlier. It will be a challenge but can be done. A box end wrench will fit on the nut.

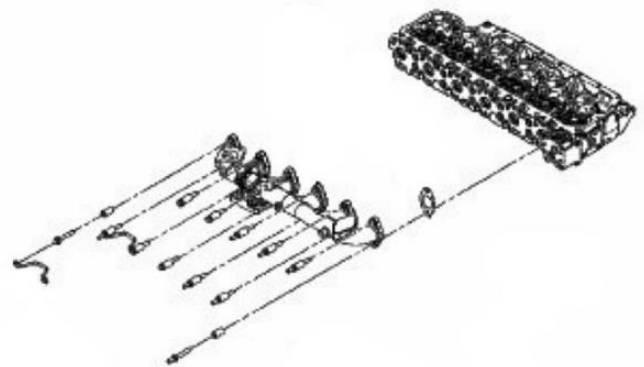

8. The five exhaust manifold cap screws with studs are used at No. 1 and No. 2 cylinder locations for the heat shield mounting and one on the rear lower corner of manifold.
9. Install the remaining bolts and spacers with gaskets.
10. Starting from the center and moving in a pattern outward, tighten the exhaust manifold bolts to **43 Nm (32ft-lbs)**.

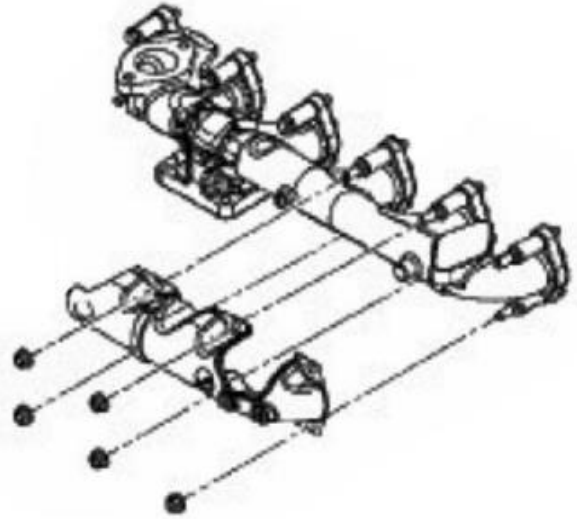

11. Install the exhaust manifold cap-screw lock plates.
 12. Install the exhaust manifold heat shields/noise panel. Tighten the mounting nuts to **24Nm (18ft-lbs)**.
 13. Install the turbocharger. Tighten turbo flange studs to **43Nm (32ft-lbs)**.
Important! Improper turbo flange torque can lead to exhaust leak and gasket failure, causing flange damage.
 14. Attach the mounting tabs and start the delta-P tube to the exhaust manifold and thermostat cap-screws.
 15. Tighten the delta-P line bracket nut to **24Nm (18ft-lbs)**.
 16. Tighten the delta-P line bolt to **10Nm (89in-lbs)**.
 17. Tighten the delta-P flare nut to **10Nm (89in-lbs)**, into the 1453149 fitting installed on the manifold.
 18. Install the EGR cooler.
 19. Install the air filter housing.
 20. Filter the coolant as per factory specifications.
 21. Connect the battery negative cables.
- Start engine and check for leaks.