



***DOWNLOAD THE LATEST
INSTALL MANUALS AT
www.bddiesel.com***



BD Dodge Cummins Cab & Chassis Exhaust Manifold

1045968	2013-2018 Dodge 6.7L Cab & Chassis
1046068	2013-18 Dodge 6.7L C&C Complete Kit

Please read all instructions before installation

Common Kit Contents – 1045968 & 1046068

Manifold	1453149	1462431
		
Manifold Qty: 1	Fitting; 1/8NPT to Port Qty: 1	Stud; M10-1.5 Short Qty: 2
1462430	1200208	1462441
		
Stud; M10-1.5 Long Qty: 3	Plug; 1/8" NPT Hex Qty: 2	Nut; M10-1.5 Qty: 9

Additional Kit Contents – 1046068 Only**





1405900	1405904	5260648
		
Manifold Gasket 6-Pack Qty: 1	EGR Gasket Qty: 1	Turbo Gasket Qty: 1
1405937	FK-1045982	
		
Bolt Spacers Qty: 12	M10x60 Qty: 12	M10x35 Qty: 2
		M10 Washer Qty: 2

Table of Contents

- Kit Contents 2
- Table of Contents..... 3
- Installation..... 3
 - Removal 3
 - Installation 10

Installation

Disconnect both vehicle batteries before installation for safety, drain coolant and setup on a hoist.

Removal

1. Remove the intake housing bolt.
2. Disconnect the Mass Air Flow (MAF) (3) sensor.
3. Disconnect the TBAP (2) sensor.
4. Loosen clamp (4) and disconnect the intake air tube (5) from the air cleaner body (1).
5. List and remove air cleaner body (1).

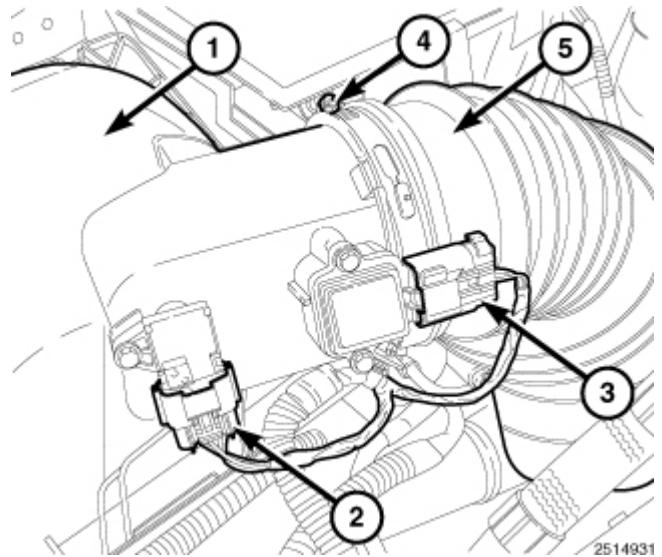

2514931

6. Disconnect the breather hose (3).
7. Loosen the clamp (1) and remove the outlet (2) tube from turbocharger.
8. Remove the four bolts and the engine cover.

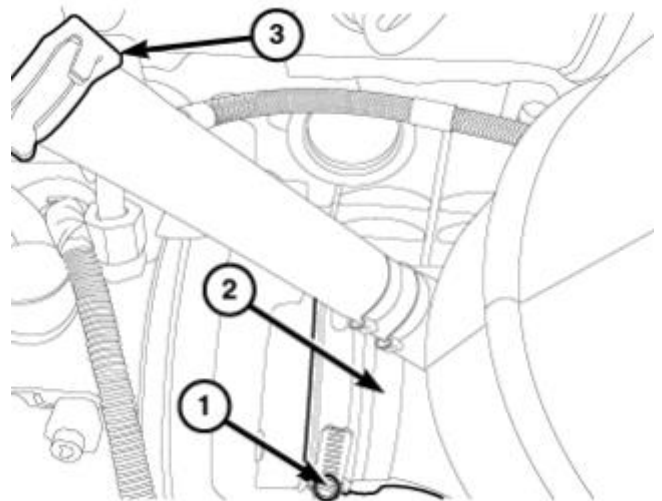

2423891

9. Disconnect the coolant bottle hose (4).
10. Remove the banjo bolt (2) securing coolant hoses.

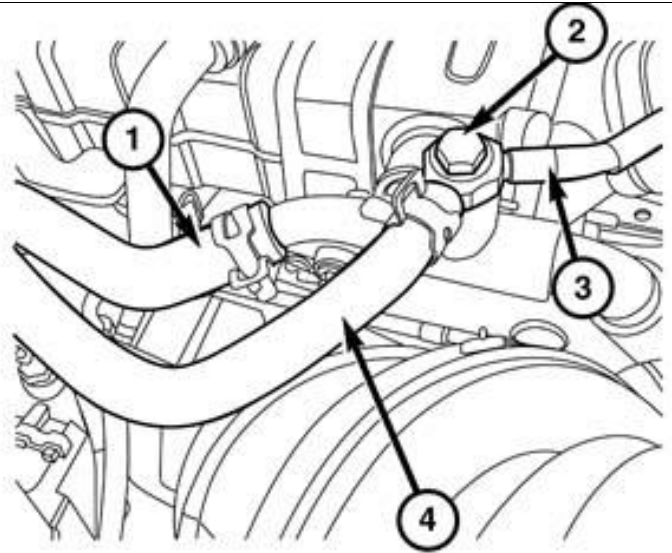

11. Remove the bolts (2) and the EGR crossover tube (3) at the EGR cooler (1).

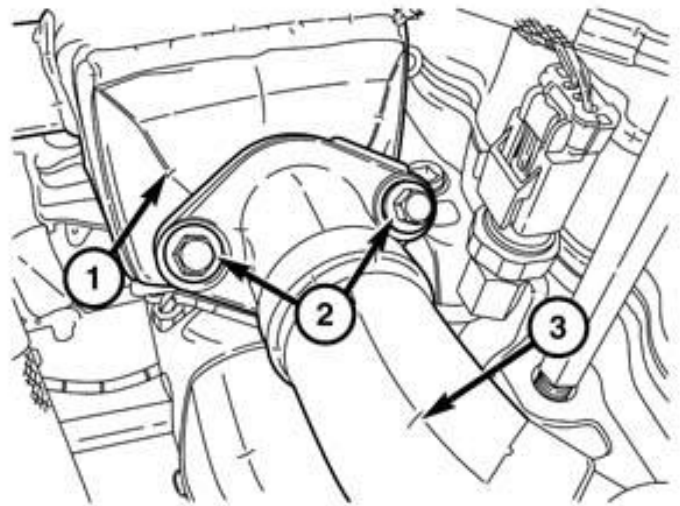

091174896

12. Disconnect the breather hose (1), remove the bolt (3), and the breather tube (2).

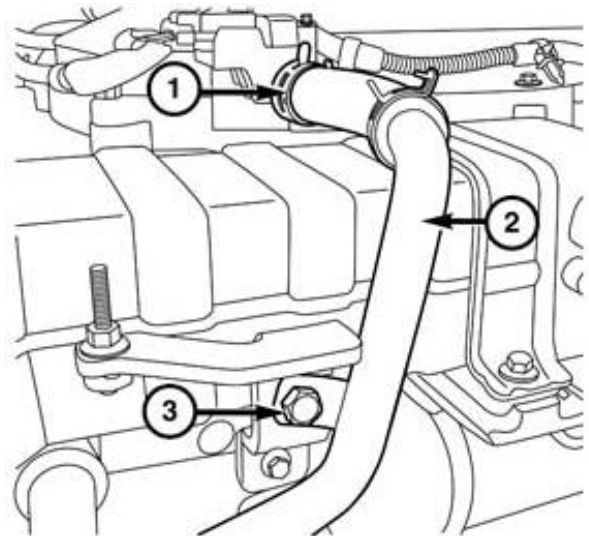

0709003096

13. Remove the bolt (2), and the front coolant outlet tube (1) from connection.

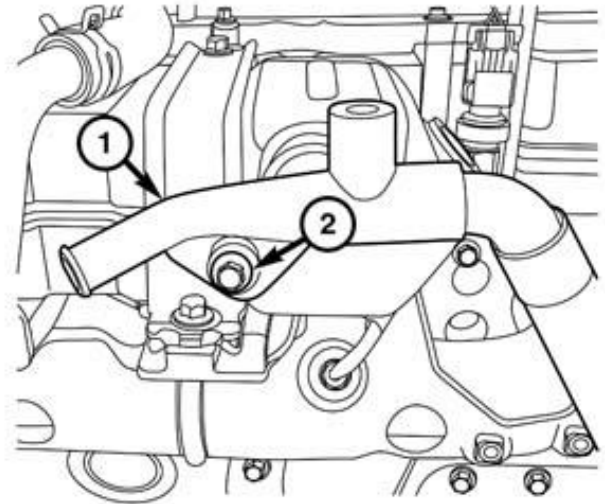

14. Remove the exhaust pressure sensor wire harness connector.
15. Remove the bolt (2) securing the exhaust pressure sensor tube to cylinder head.
16. Remove fitting (3) and the exhaust pressure sensor tube (1).

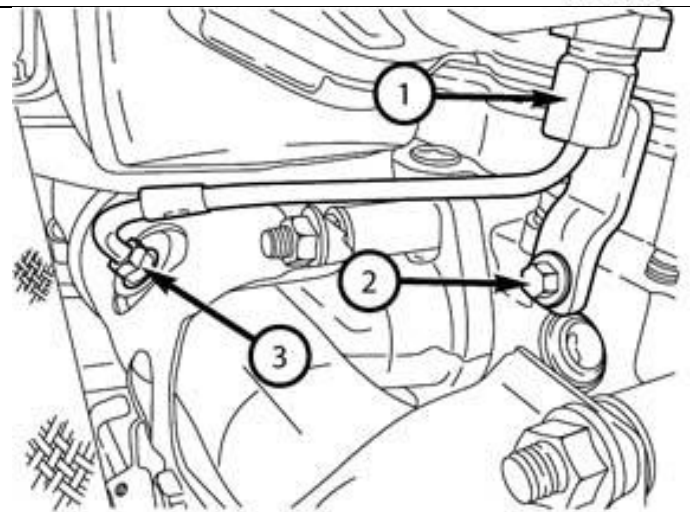

17. Remove the bolt (1), and the rear coolant inlet tube (2) from connection.

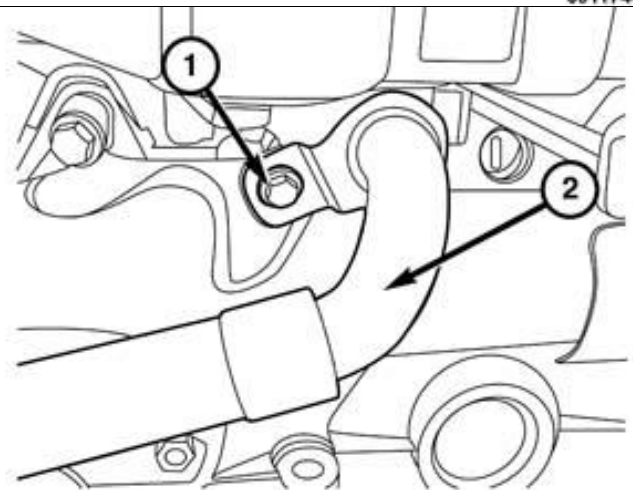

- 18. Remove the EGR cooler mount bolts (1).

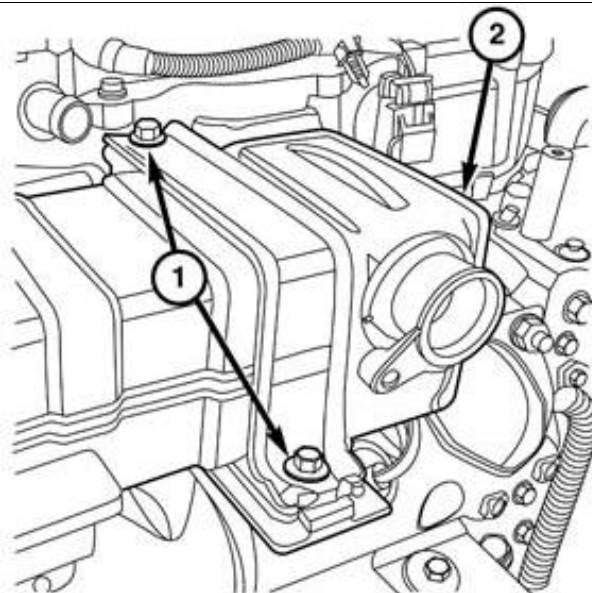

0709003097

- 19. Remove nuts (3) and the EGR cooler.

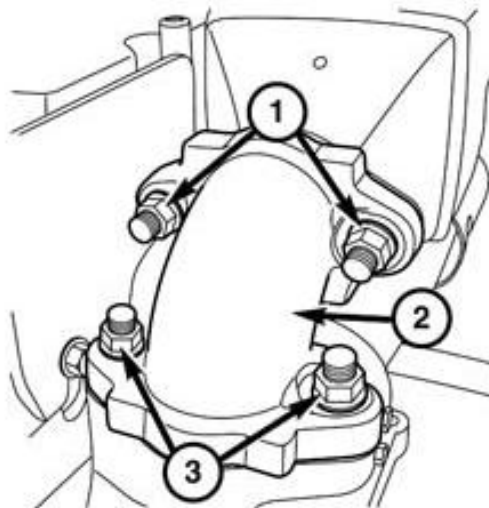

0913002104

20. If required, remove the bolt (2) and the rear EGR cooler inlet tube (1).

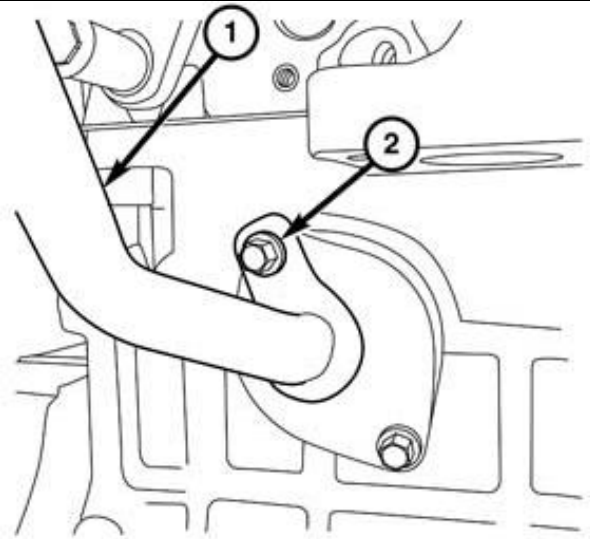

21. If required, remove the lower bolt (2) and the front EGR cooler outlet tube (1).

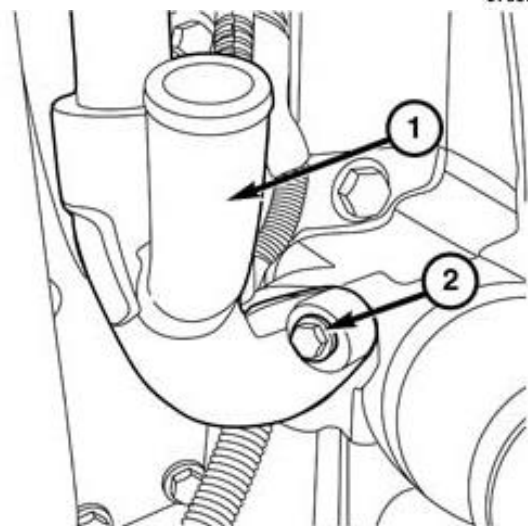

22. Remove the heat shield and noise panel (if equipped) from the exhaust manifold.

23. Loosen the clamp (1) and remove the charge air tube (2) from the turbocharger outlet.

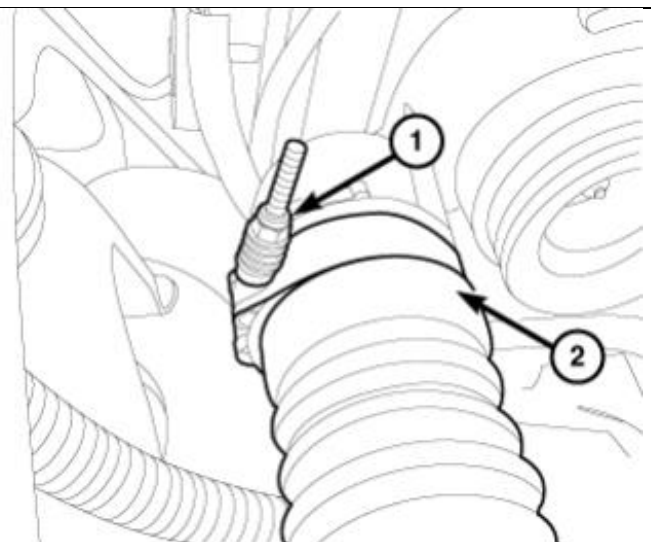

- 24. Disconnect the turbocharger speed sensor wire harness connector.
- 25. Disconnect the turbocharger actuator wire harness connector.
- 26. Remove the turbocharger oil pressure line (3).
- 27. Remove the turbocharger coolant lines at engine block and turbocharger.

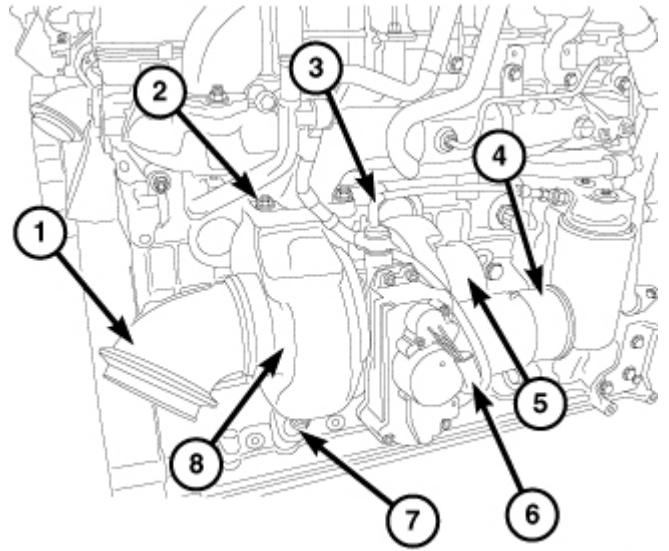

1283861

- 28. Remove the right-side wheelhouse splash shield.
- 29. Install the engine support fixture tool 8434B.
- 30. Remove the right-hand side engine mount. (NOTE: engine mount does not need to fully removed, just repositioned).

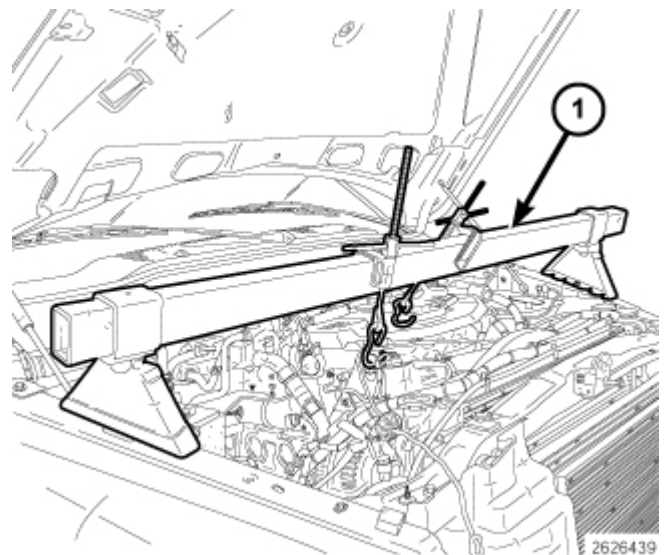

2626439

- 31. Raise and support the vehicle.
- 32. Remove the exhaust steady rest bracket from transmission.
- 33. Remove the V-band clamp (1) from the turbocharger exhaust outlet.

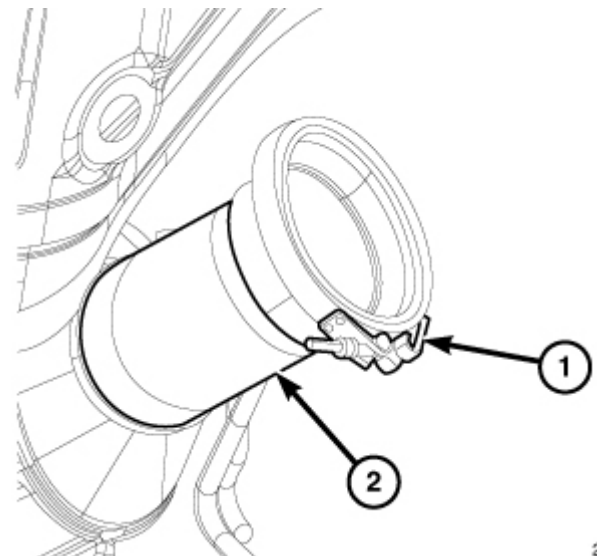

2592481

34. Remove the turbocharger drain tube (2) from the turbocharger and cylinder block.
35. Lower the vehicle.
36. Remove and position aside the grid heater relay from battery tray.
37. Using Tool 9866, remove the turbocharger to exhaust manifold mounting nuts.
38. Remove the turbocharger from the vehicle by lifting from top of the engine compartment.

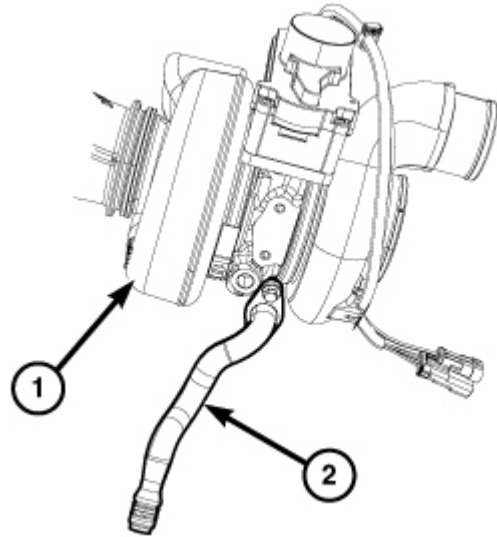

2595525

39. Remove the two (2) rear exhaust manifold cap-screw lock plates.
40. Remove the Cab heater tubing/bracket from the exhaust manifold stud.
41. Remove the exhaust manifold.

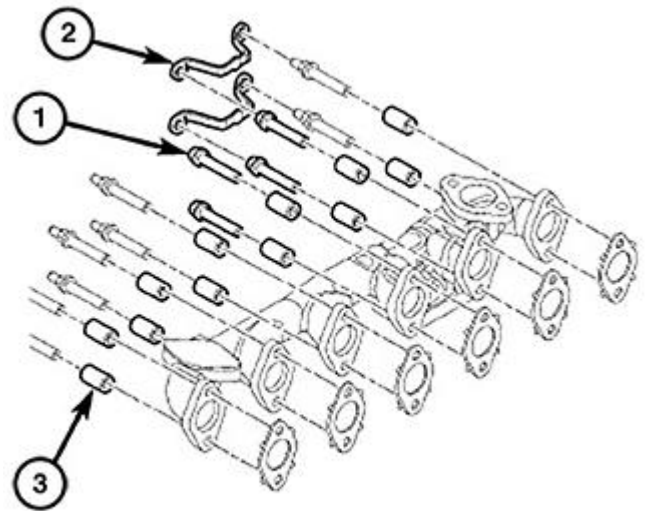

81af5a81

Installation

1. Referring to the following picture to know the location of studs and fittings on in respect to the manifold.

NOTE: EGR Bracket **MUST** be installed prior to the installation of the manifold, the EGR Bracket will not slide into position if this is not done.

1045968- 13-18 C&C Manifold

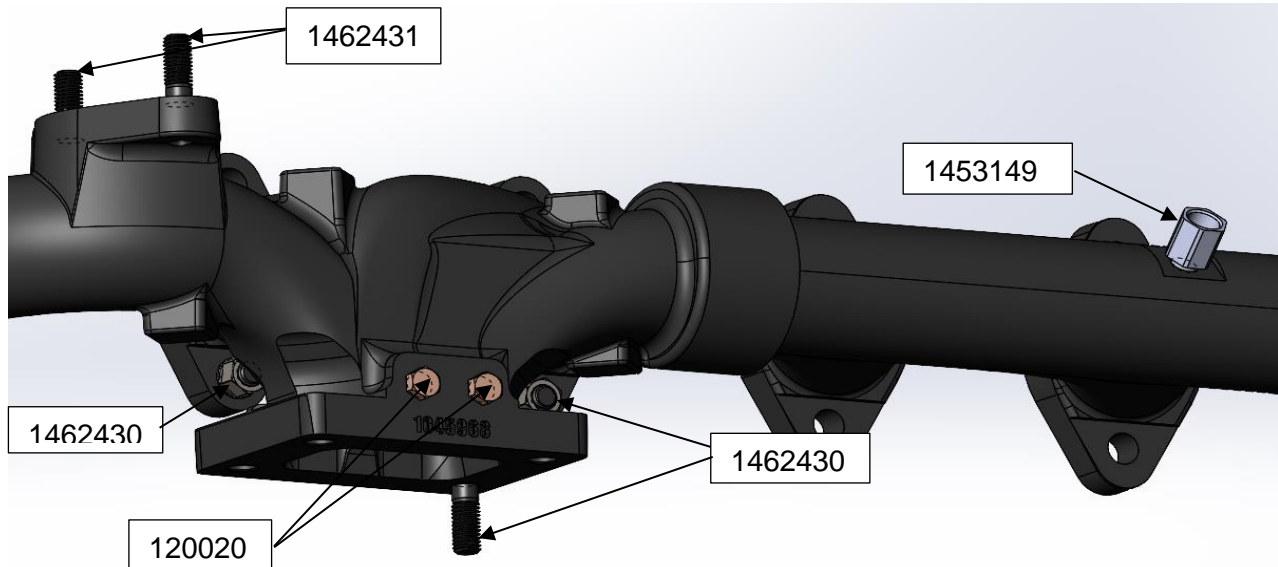

2. Clean the cylinder head exhaust port gasket surfaces.
3. Clean the turbo mounting flange on the turbocharger.
4. Install exhaust manifold with one factory bolts and the 1462430 studs to hold in place
5. Using the supplied studs, insert the studs at the lower mount of exhaust of cylinders 4 and 5. Lift the manifold into place and use these studs as support. Don't forget to install gaskets.
6. Insert a factory bolt at the lower threaded mount of cylinder 2 with gasket. Keep this bolt loose.
7. Use the supplied M10 nuts on the studs installed earlier. It will be a challenge but can be done. A box end wrench will fit on the nut.

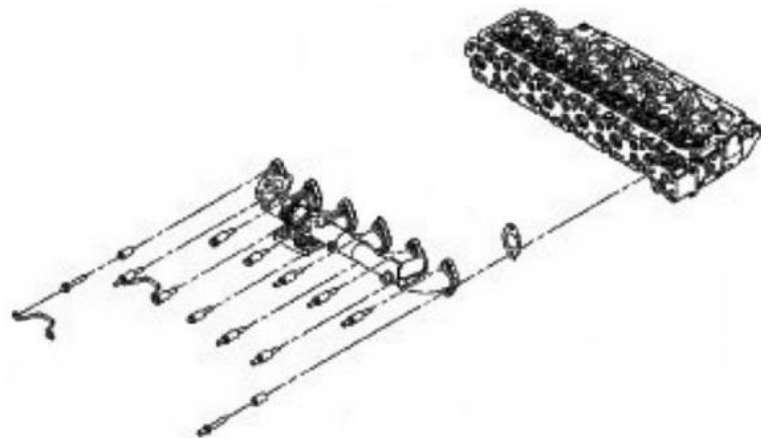

8. The five exhaust manifold cap screws with studs are used at No. 1 and No. 2 cylinder locations for the heat shield mounting and one on the rear lower corner of manifold.
9. Install the remaining bolts and spacers with gaskets.
10. Starting from the center and moving in a pattern outward, tighten the exhaust manifold bolts to 43 Nm (32ft-lbs).

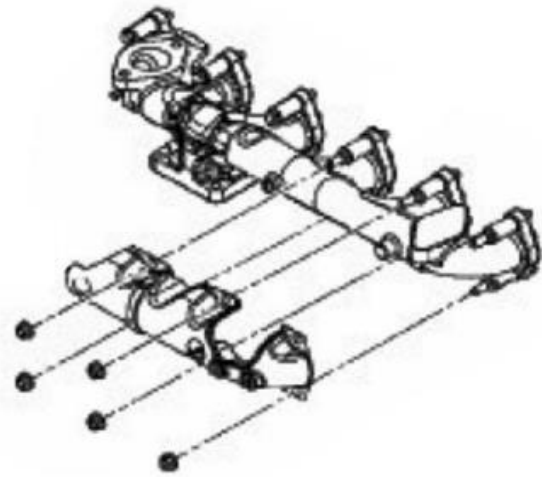

RE-INSTALLATION PROCESS IS REMOVAL BUT REVERSED

11. Install the exhaust manifold cap-screw lock plates.
12. Install the exhaust manifold heat shields/noise panel. Tighten the mounting nuts to 24Nm (18ft-lbs).
13. Install the turbocharger. Torque nuts to 43Nm (32ft-lbs)
Important! Improper torque can lead to gasket failure and flange damage!
14. Attach the mounting tabs and start the exhaust pressure sensor tube to the exhaust manifold and thermostat cap-screws.
15. Tighten the exhaust pressure sensor tube bracket nut to 24Nm (18ft-lbs).
16. Tighten the exhaust pressure sensor tube line bolt to 10Nm (89in-lbs).
17. Tighten the exhaust pressure sensor tube flare nut to 10Nm (89in-lbs), into the 1453149 fitting installed on the manifold.
18. Install the EGR cooler.
19. Install the air filter housing.
20. Filter the coolant as per factory specifications.
21. Connect the battery negative cables.

Start engine and check for leaks.
