



# INSTALLATION INSTRUCTIONS

## AUTOMATIC TRANSMISSION FILTER KIT

### PART # 13090

Please read these instructions completely before starting the installation.

#### KIT CONTENTS

QTY.	DESCRIPTION	QTY.	DESCRIPTION
1	Filter Mount	2	3/8" NPT x 3/8" Barb Fittings
1	Oil Filter	1	Insta-dapt Adapter
3	#14 Sheet Metal Screws	4	Hose Clamp
4ft	11/32" OEM Spec Hose	1	3/4-16 Filter Nipple

#### TOOLS NEEDED

Standard Screw Driver	Drill
or 5/16" Nut Driver	3/16" Drill Bit
5/8" Open End Wrench	Teflon Tape
3/4" Open End Wrench	Marker
Razor Knife	

### INSTALLATION

#### Filter Mount

- Choose a convenient location for the Filter Mount, making sure there is enough space for future servicing of the oil filter.  
Suggested Locations: Firewall, Radiator Support, Fender well
- Take the 3/4-16 Filter Nipple supplied and install onto the Filter Mount, making sure the shorter end of threads is towards the Filter Mount. (See Diagram #1)
- Using the filter mount as a template, mark and drill three 3/16" holes.
- Using the #14 Sheet Metal Screws provided, install the Filter Mount onto the vehicle.
- Identify the 3/8" NPT x 3/8" Barb Fittings, using Teflon Tape or suitable Sealant install the two 3/8" NPT x 3/8" Barb Fittings onto the Filter Mount.
- Apply a light coat of oil onto the o-ring of the oil filter and install on the filter mount.

#### Locate Transmission Lines

- Find the two transmission oil lines that run from the transmission to the radiator, usually steel lines connected to the bottom radiator tank or on a cross-flow radiator the passenger side tank.
- Determine the supply line to the transmission. Warm up vehicle & feel the trans lines, the warmer of the two lines will be the supply line.

#### Hose Connections

- Disconnect the supply transmission cooler line from the radiator.
  - Take the supplied Insta-dapt Adapter fitting and install onto radiator using the appropriate Male or Female end. (See Diagram #2)
- Note:** The Insta-dapt fitting has a 1/2"-20 Thread and fits most vehicles with 5/16" transmission cooler lines. For vehicles that are not compatible with the Insta-dapt Adapter, please reference the Radiator Adapter Fitting Guide or go to [www.derale.com](http://www.derale.com) for alternative radiator fitting options.
- Using the supplied Hose and Hose Clamps, Connect both ends of the Hose to the 3/8" NPT x 3/8" Barb Fittings now installed on the Filter Mount forming a loop.
  - Carefully route the looped Hose to the desired locations.
  - Cut and attach the Hose coming from the IN on the Filter Mount to the supply line coming from the Transmission.
  - Cut and attach the Hose coming from the OUT on the Filter Mount to the Insta-dapt Adapter now attached to the Radiator.

**Warning:** When routing hoses, be sure to keep all hoses away from sharp edges, moving parts and hot engine components. Hoses should be routed carefully and should not be bent in less than a 3" radius.

**Important:** A kinked hose will restrict flow and could cause transmission failure.

**Note:** Filter element should be replaced every 25,000 miles or whenever the transmission is serviced. Order Derale replacement filter element part #13092.

#### SYSTEM CHECK

- Start the vehicle and quickly check all connections for leaks.
- With the vehicle in neutral, check the transmission fluid level.
- Add fluid as needed.
- Drive vehicle making sure transmission is warm, then recheck fluid level.

**Warning:** Installation of accessories should only be undertaken by those with mechanical knowledge and are familiar with working on vehicles. Always use eye protection (goggles, safety glasses or shield). Park the vehicle in a well lit area, on level ground and apply the parking brake. Only work on a cold vehicle that has been sitting overnight, failure to do so will result in severe burns and injury. Before starting the vehicle, make sure no tools or any other items are left under hood that could interfere with or be drawn into moving parts of the engine. Failure to follow instructions can lead to severe damage and personal injury.

#### Diagram #1

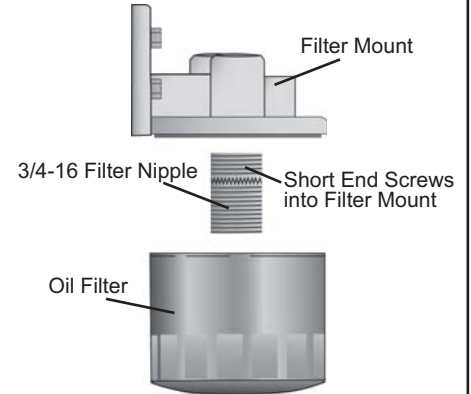

#### Diagram #2

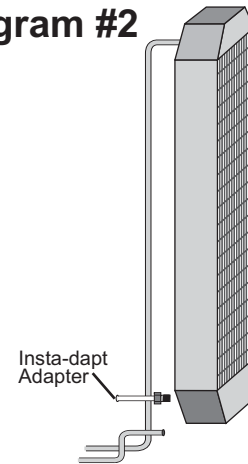

#### Diagram #3

