

Firestone

AIRIDE

riderite.com

INSTALLATION INSTRUCTIONS

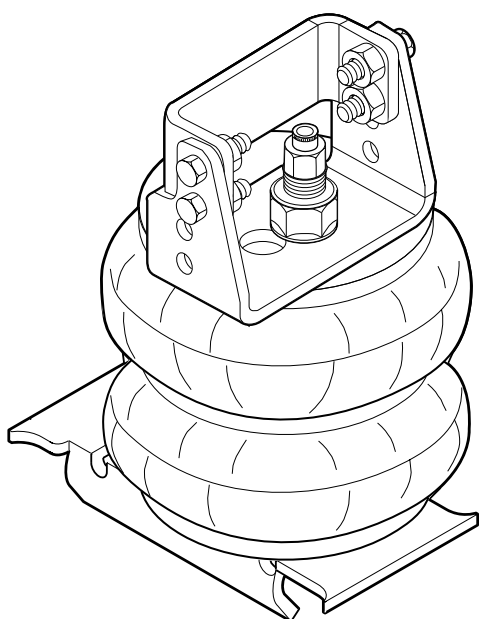

SECTION 1 - AIR SPRING

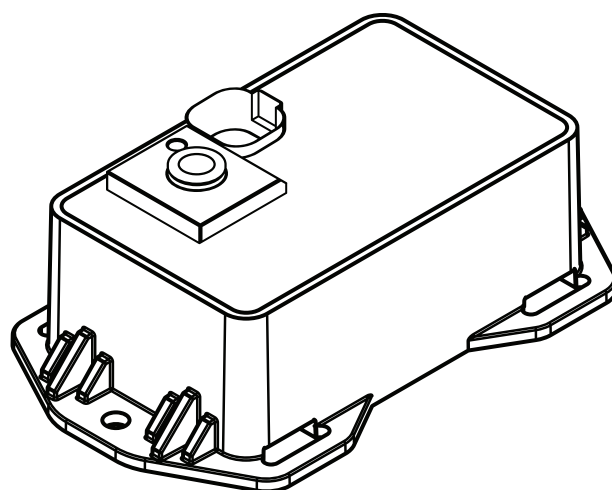

SECTION 2 - AIR ACCESSORY



riderite.com

INSTALLATION INSTRUCTIONS

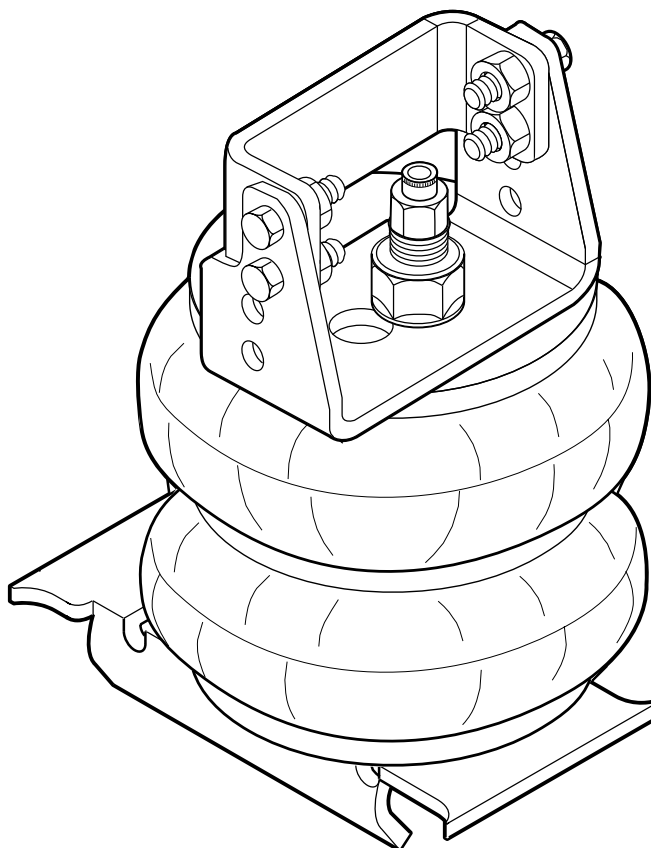

Firestone

*World's Number 1
Air Spring.*



FIRESTONE INDUSTRIAL PRODUCTS COMPANY

! IMPORTANT

PLEASE DON'T HURT YOURSELF, YOUR KIT OR YOUR VEHICLE. TAKE A MINUTE TO READ THIS IMPORTANT INFORMATION.

This kit is to be used on a **pickup truck only**, and **DOES NOT INCREASE YOUR VEHICLE'S MAXIMUM LOAD**.

SAFE INSTALLATION

Please take all safety precautions during installation. A hydraulic jack can fail, and if that happens, you can be seriously hurt, or worse, if you are relying on it to hold up the vehicle. If you use a hydraulic jack, secure jack stands in the appropriate locations and chock any tires still touching the ground.

Wear safety glasses or goggles. Your eyes may be lower than some parts and pieces, and you don't want to lose an eye.

Remove the possibility of any electrical issues by disconnecting the negative battery cable.

KIT CLEARANCE

There must be a minimum of 1/2" clearance around all installed components when the Air Springs are inflated and under a load. The Air Springs must flex and expand during operation, so the clearance keeps the kit from rubbing against parts of the vehicle.

VEHICLE GVWR

NEVER exceed the maximum load recommended by the vehicle manufacturer (GVWR). The GVWR can be found in your vehicle's owner's manual or on the data plate on the driver's side door. Consult your local dealership for additional GVWR specifications.

INFLATING THE AIR SPRINGS

When inflating Air Springs, add air pressure in small quantities, checking air pressure frequently. The Air Springs have much less air volume than a tire, so they inflate much more quickly.

PRESSURE TO LOAD

The Air Springs will support approximately 50 lbs. of load for each PSI of inflation pressure (per pair). For example, 50 PSI of inflation pressure will support a load of 2500 lbs. per pair of Air Springs.

APPROPRIATE AIR PRESSURE

For best ride, use only enough air pressure in the Air Springs to level the vehicle when viewed from the side (front to rear). This will vary, depending on the load, location of the load, condition of the existing suspension, and personal preference.

OPTIONAL T-FITTING

This kit includes Inflation Valves and Air Line Tube for each Air Spring, allowing you to compensate for unbalanced loads. If you prefer a single Inflation Valve system to provide equal pressure to both Air Springs, your dealer can supply the optional "T" fitting (Part # 3025 or WRI-760-3461 retail pack).



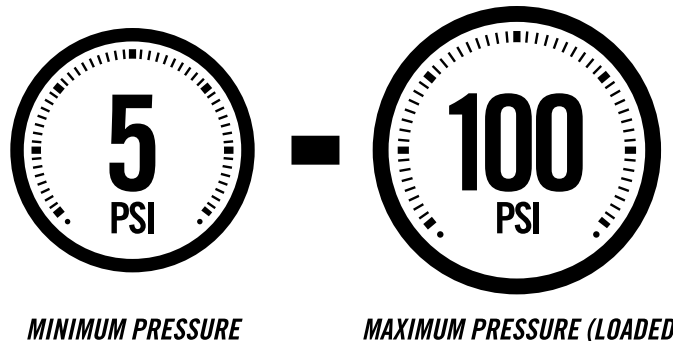

ONCE INSTALLED SUCCESSFULLY, FOLLOW THESE PRESSURE REQUIREMENTS FOR THE AIR SPRINGS:



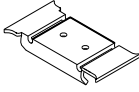
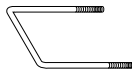
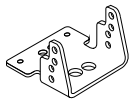
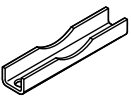

PARTS

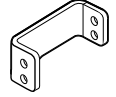
Compare the parts below to your kit. Assure you have all pieces, and organize them for an easier installation.

MAIN KIT CONTENTS

PART # 6401	 x2 AIR SPRING	PART # 5370	 x2 LOWER BRACKET	PART # 3292	 x2 BAIL CLAMP
PART # 5757	 x2 UPPER BRACKET	PART # 5181	 x2 AXLE STRAP BRACKET	PART # 1004	 x1 HEAT SHIELD
PART # 5758	 x2 UPPER BRACE	PART # 9415	 x1 AIR LINE TUBE (22 FEET)		







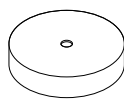



A24-760-7560 INFLATION VALVE BRACKET KIT

PART # 9483	 x1 NO-DRILL INFLATION VALVE BRACKET	PART # 9488	 x2 LARGE NYLON TIE
-------------	---	-------------	---

A24-760-7562 SPACER PACK

PART # 5336	 x2 AIR SPRING SPACER (see page 5 for important details).
-------------	---

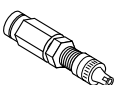
A21-760-2299 HARDWARE PACK

PT # 3150	 x2 3/8" - 16 x 2" FLANGE BOLT	PT # 3067	 x12 3/8" - 16 FLANGE LOCK NUT	PT # 3293	 x4 M10 - 1.50 x 30mm FLAT HEAD BOLT
PT # 3069	 x2 3/8" - 16 x 3/4" FLANGE BOLT	PT # 3295	 x2 3/4" - 16 HEX NUT	PT # 0070	 x8 3/8" - 16 x 1" HEX HEAD BOLT
PT # 3064	 x2 3/4" INTERNAL TOOTH LOCK WASHER	PT # 3033	 x4 5/16" FLAT WASHER	PT # 9036	 x6 RED NYLON TIE
PT # 3032	 x2 INFLATION VALVE AND VALVE CAP ASSEMBLY	PT # 3046	 x2 AIR FITTING	PT # 0899	 x2 THERMAL SLEEVE

CONTENTS AND OVERVIEW

PAGE 4	REMOVE JOUNCE BUMPER & SELECT LOWER BRACKET ORIENTATION
PAGE 5	FASTEN AIR SPRING TO LOWER BRACKET
PAGE 6	UPPER BRACKET ASSEMBLY & INSTALLATION
PAGE 7	AIR SPRING ASSEMBLY INSTALLATION
PAGE 8	AXLE STRAP BRACKET INSTALLATION
PAGE 9	HEAT SHIELD & PASSENGER SIDE
PAGE 10	AIR LINE TUBE & INFLATION VALVE INSTALLATION
PAGE 11	INSTALL & ROUTE AIR LINE TUBE
PAGE 12	CHECKING THE SYSTEM
PAGE 13	FIXING AN AIR LEAK
PAGE 14	FINISHING THE INSTALLATION

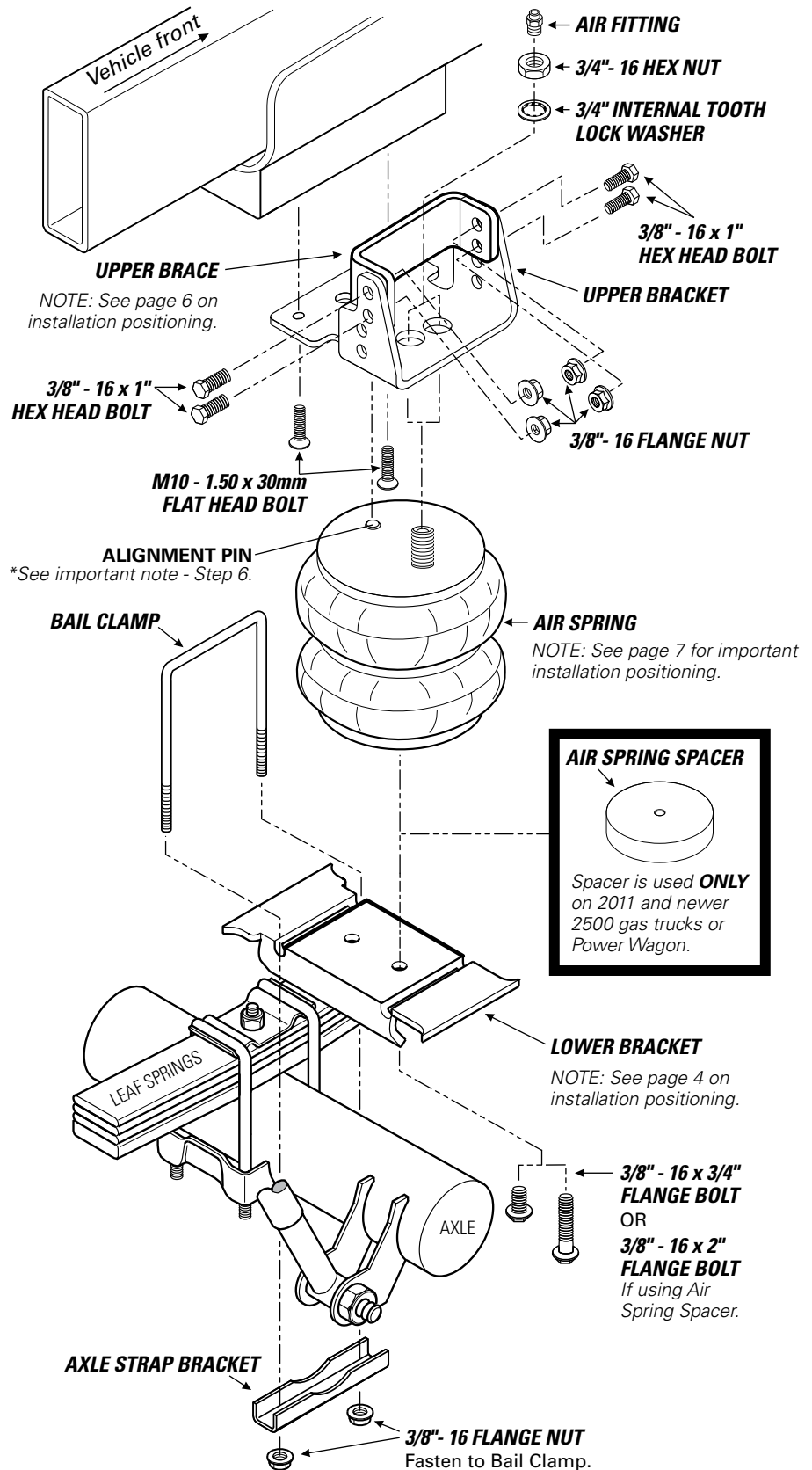

REMOVE EXISTING JOUNCE BUMPER

1



START THE INSTALLATION ON THE LEFT SIDE OF THE VEHICLE WHEN FACING FORWARD.

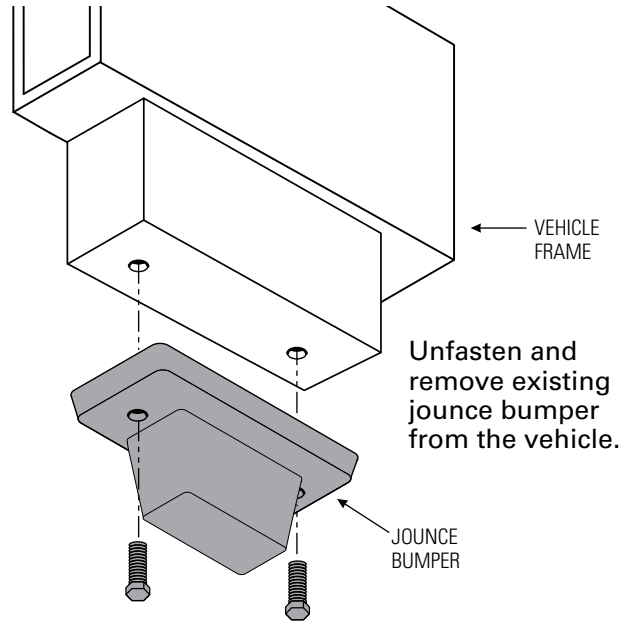

DETERMINE LOWER BRACKET ORIENTATION

2

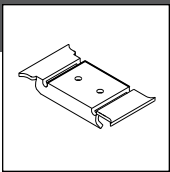

THE ORIENTATION OF THE BRACKET IS IMPORTANT. NOTE THE DIFFERENCE AND USE THE CORRECT SIDE FOR YOUR VEHICLE.

LOWER BRACKET ORIENTATION

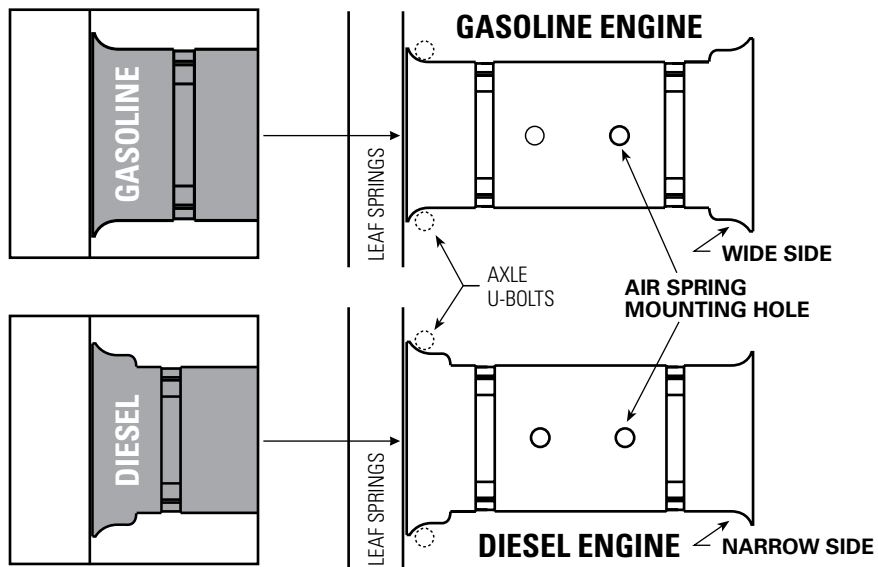

3

FASTEN AIR SPRING TO LOWER BRACKET

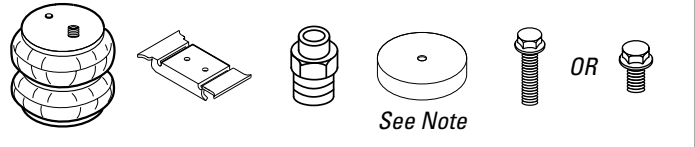

1 Install the Air Fitting into the Combo Stud on the top of the Air Spring.

2 Use the notes below to determine if you need to use the Air Spring Spacer.

3 Install the Air Spring to the Lower Bracket, using the fastener selected below.

4 Do not fully tighten the fastener at this stage.

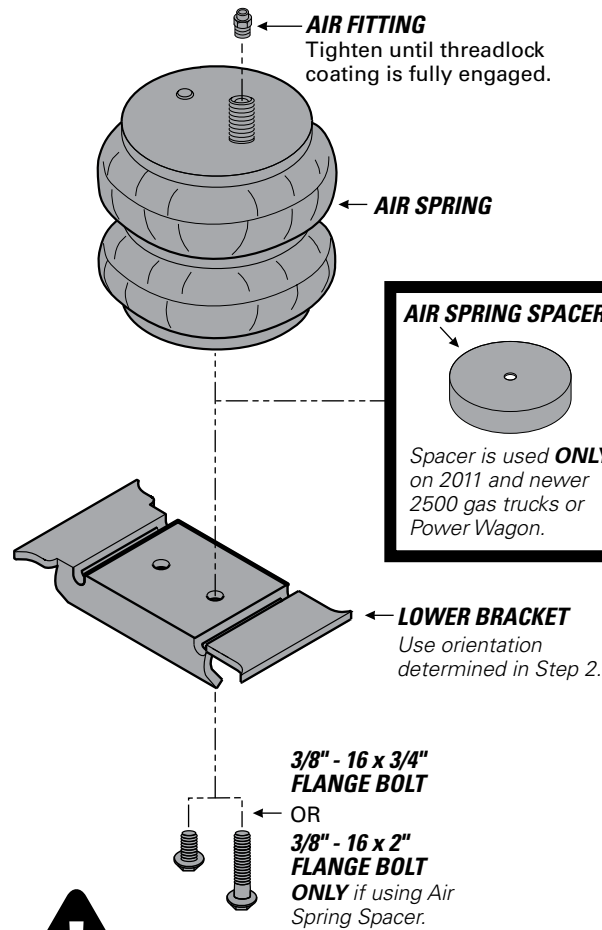

THE AIR SPRING SPACER SHOULD ONLY BE USED ON 2011 AND NEWER 2500 GAS TRUCKS OR POWER WAGON. **USING THE AIR SPRING SPACER ON ANY OTHER VEHICLES WILL VOID THE WARRANTY.**



DO NOT FULLY TIGHTEN THE BOLT AT THIS STAGE. TORQUE TO SPEC IN STAGE 6.

ASSEMBLE THE UPPER BRACKET AND UPPER BRACE

4

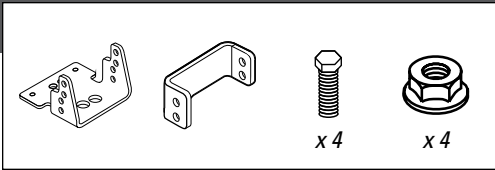

1 Determine bolt holes in Upper Bracket and Upper Brace for your vehicle.

2 2WD uses the lower holes marked "2WD." 4WD uses the upper holes marked "4WD."

3 Align holes in both brackets and secure with fasteners, as shown in the 2WD installation.

2WD INSTALLATION

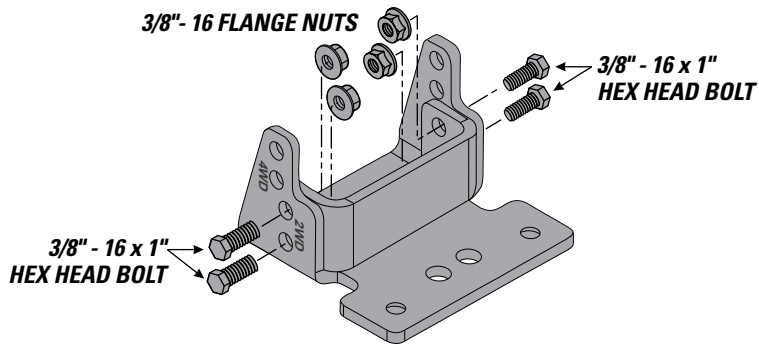

4WD INSTALLATION

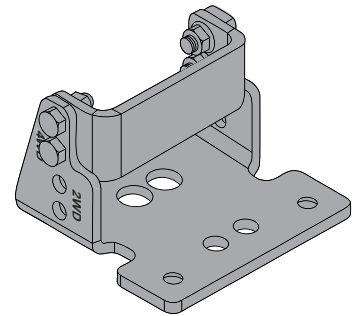

INSTALL THE UPPER BRACKET ASSEMBLY

5

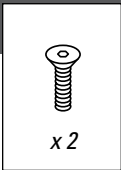

MAKE SURE THE UPPER BRACKET ASSEMBLY IS FASTENED TIGHTLY TO THE VEHICLE FRAME.

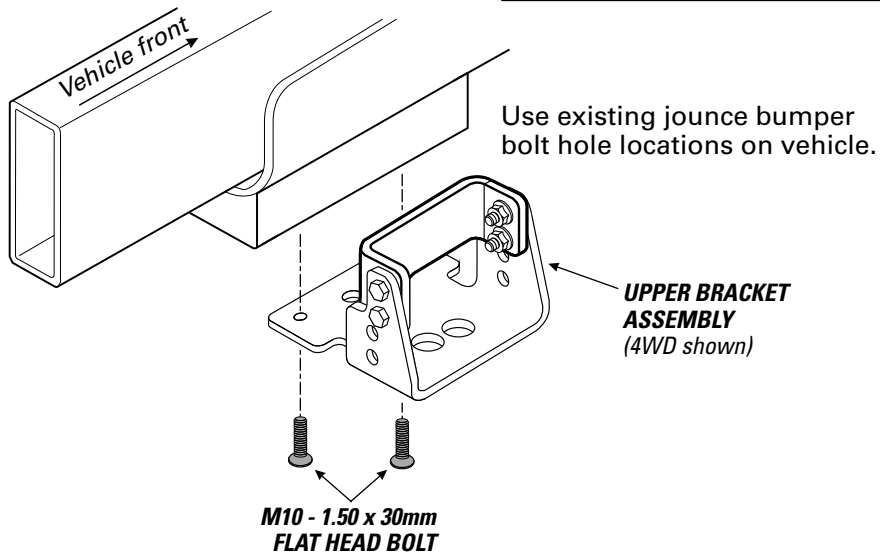

6

INSTALL AIR SPRING ASSEMBLY

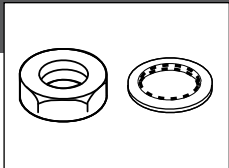

INSTALLING THE RIGHT SIDE? REMEMBER STEP 8 FIRST!

- 1** Follow guidelines below to dry fit assembly. Make alignment marks as shown.
- 2** Remove assembly and match alignment marks you made.
- 3** Fully tighten the bolt selected in Step 3 to fasten the Air Spring to the Lower Bracket.
- 4** Install assembly and follow the guidelines.

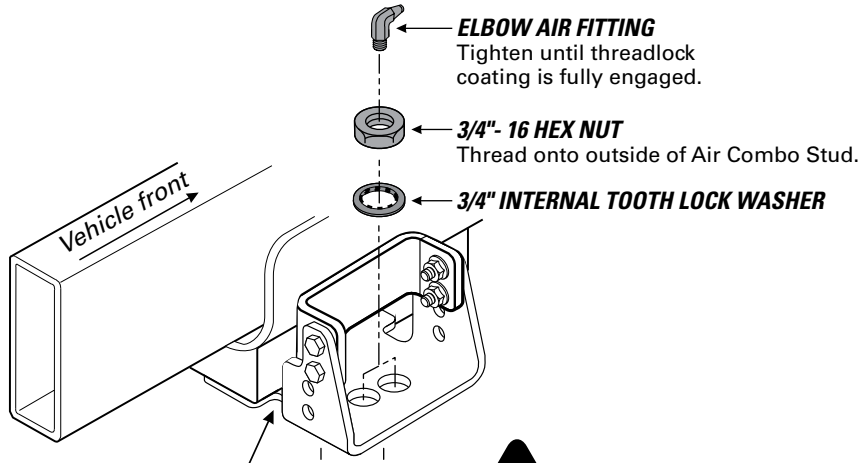

VIEW FROM BELOW

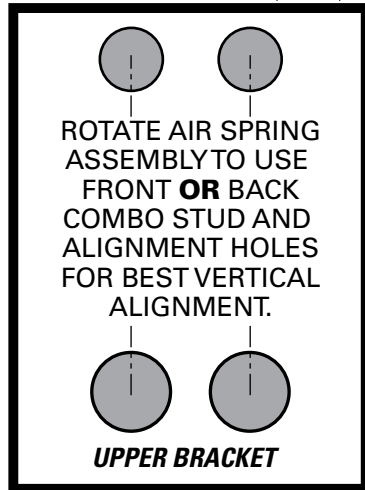

ALIGNMENT PIN ON AIR SPRINGS MUST BE FULLY SEAT INTO ONE OF THE ALIGNMENT HOLES IN THE UPPER BRACKET. FAILURE TO DO SO WILL CAUSE IT TO BE PUSHED INTO THE BEAD PLATE, CREATING AN AIR LEAK, AND RESULTING IN AN AIR SPRING FAILURE THAT IS **NOT WARRANTABLE. THE ALIGNMENT PIN CANNOT HOLD 2,500 LBS! IT IS USED FOR ALIGNMENT ONLY!**

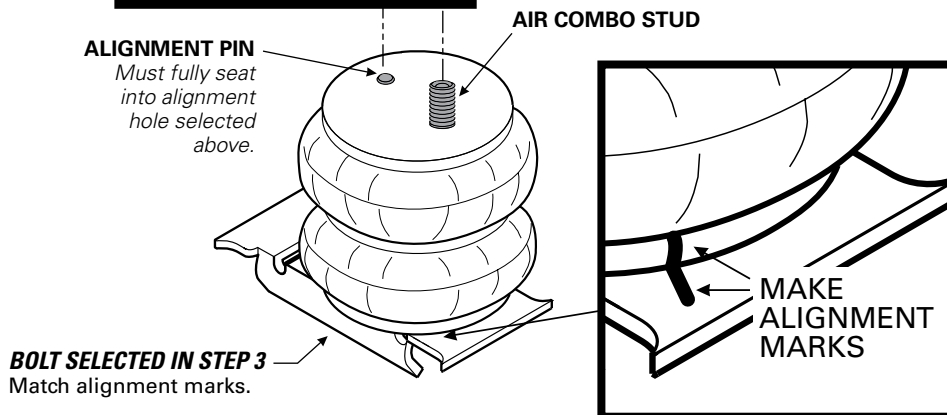

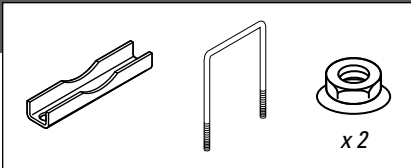

1 Assure that Lower Bracket is tight against the leaf spring stack on the vehicle.

2 Install the Bail Clamp over the Lower Bracket, assuring that the Bail Clamp is positioned into the Lower Bracket notches, as shown.

3 Alternate tightening of the 3/8"-16 Flange Nuts to draw Axle Strap Bracket evenly around the axle.

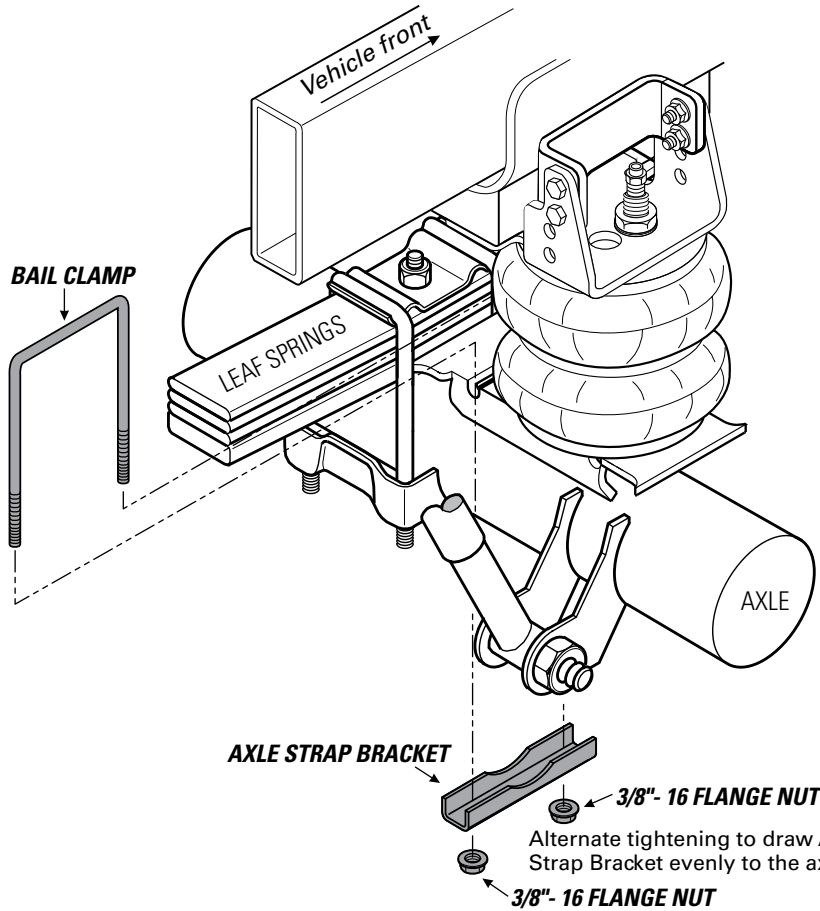

BAIL CLAMP INSTALLED

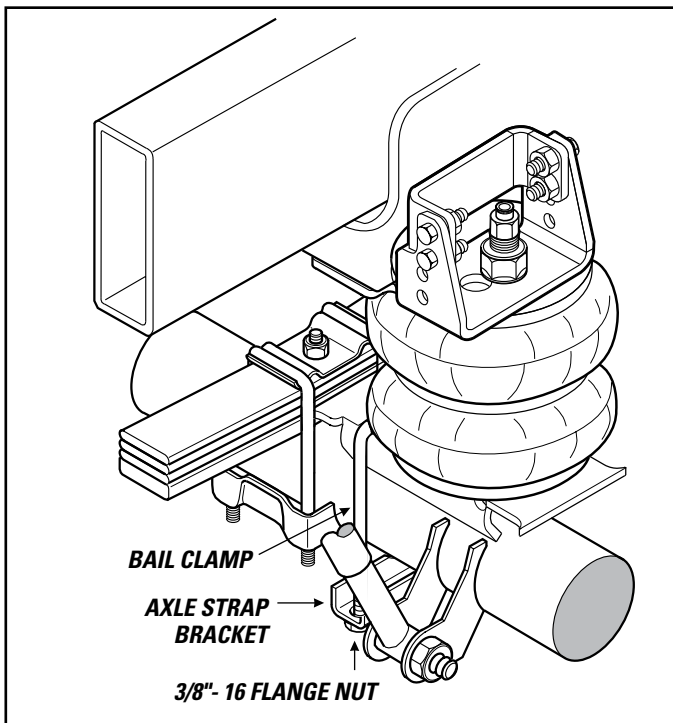

USE YOUR HAND TO CHECK FOR THE PROPER CLEARANCE AROUND THE AIR SPRING. IF YOUR HAND DOES NOT FIT BETWEEN THE AIR SPRING AND OTHER COMPONENTS, IT WILL RUB!



AWESOME! You're done with the left side. The right side installation is the same, with the addition of this step. Go complete Steps 1-5 for the right side, then complete this step before continuing to Step 6.



RIGHT SIDE INSTALLATION MUST INCLUDE HEAT SHIELD!

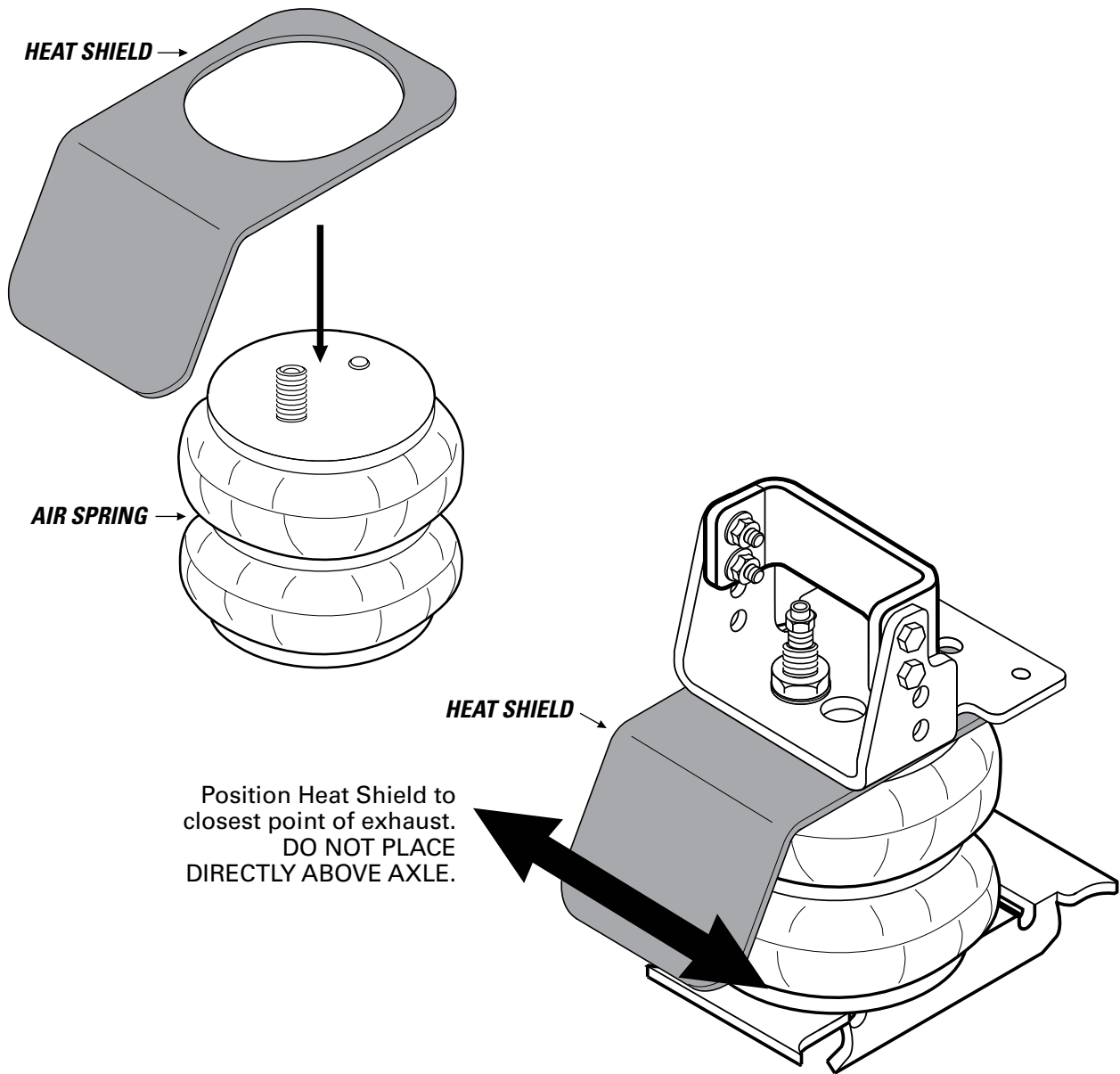

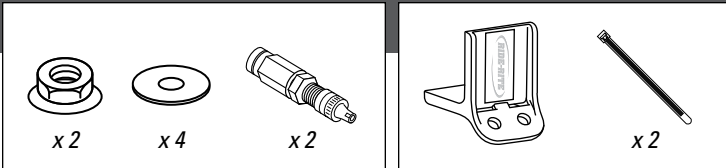

IF USING THE OPTIONAL NO-DRILL INFLATION VALVE BRACKET, CHOOSE OPTION 1. IF DRILLING, CHOOSE OPTION 2. **INFLATION VALVES MUST BE ACCESSIBLE BY AN AIR CHUCK.**

1 Secure the Air Inflation Valve Bracket to a protected, secure location. **PROCEED TO STEP 3.**

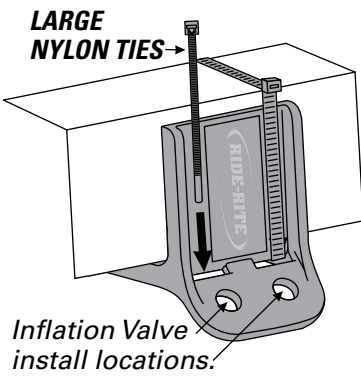

2 Select a protected location to install the Inflation Valves, such as the bumper or the body of the vehicle.

Drill two 5/16" holes for Inflation Valve install locations.

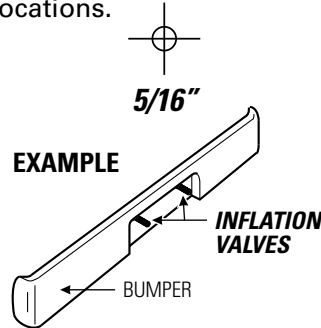

3 Install Inflation Valve assembly as shown.

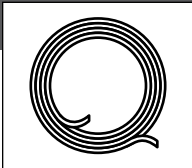
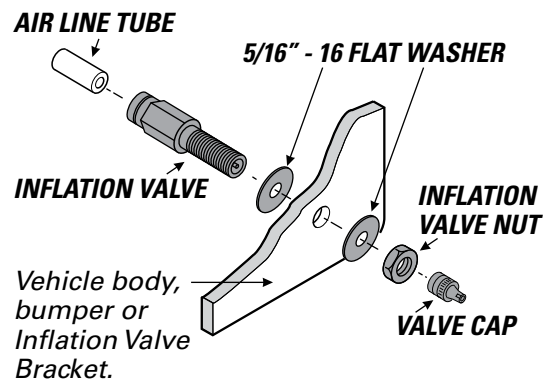

1 Match Air Line Tube ends.

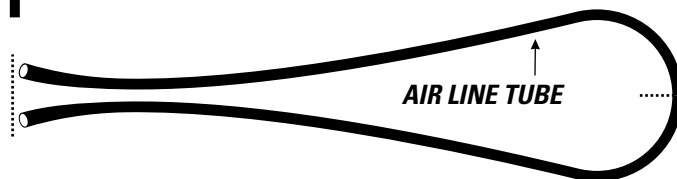

2 Find center of Air Line Tube, make a square cut with tube cutter or sharp utility knife.

DO

Make sure the cut is as square as possible. Use a tube cutter or sharp utility knife.

DON'T

Fold or kink the Air Line Tube. Cut the Air Line Tube at an angle. Use pliers, scissors, snips, saws, or side cutters.

PROPER AND IMPROPER CUTS IN THE AIR LINE TUBE

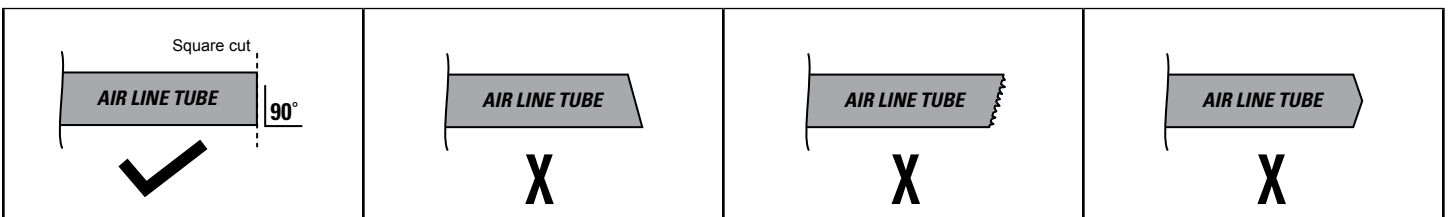

11

INSTALLING AIR LINE TUBE INTO AIR FITTINGS AND INFLATION VALVE

1 Insert end of Air Line Tube into Air Fitting.

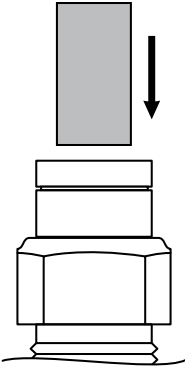

2 Push Air Line Tube into Air Fitting as far as possible.

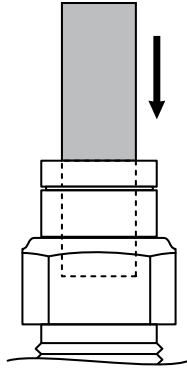

3 Gently pull on the Air Line Tube to check for a secure fit.

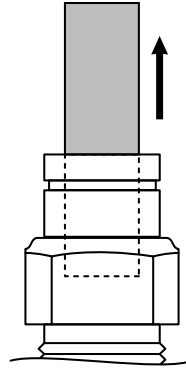

4 To remove, push down collar and gently pull Air Line Tube away.

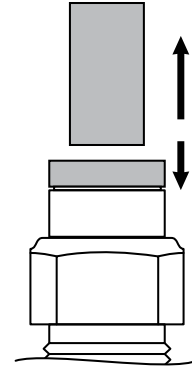

Removal Tip: Use a 1/4", 5/16", or 6mm open-ended wrench to push the collar down.

12

ROUTE AND SECURE AIR LINE TUBES

Air Line Tube routes will vary, depending on your truck, and requires you to choose the best path from the Air Springs to the Inflation Valves. Use the instructions below to help you choose.

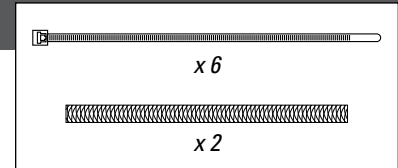

DO

Select routes protected from heat, debris, and sharp edges.
Use Thermal Shields near heat sources.
Use Nylon Ties to secure the Air Line Tube.

DON'T

Bend or sharply curve Air Line Tubes.
Leave Air Line Tube exposed to sharp edges.
Use unnecessary lengths of Air Line Tube.
Route Air Line Tube near moving parts.
Let Air Line tube hang unsecured from vehicle.
Scar Air Line Tube while routing.

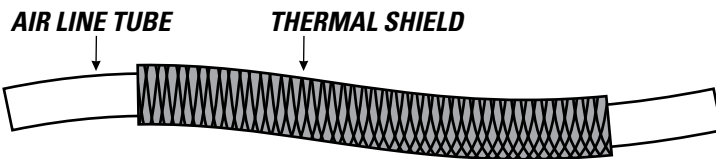

USE SUPPLIED THERMAL SHIELDS WHEN AIR LINE TUBE RUNS **WITHIN 6 INCHES** OF HEAT SOURCES.

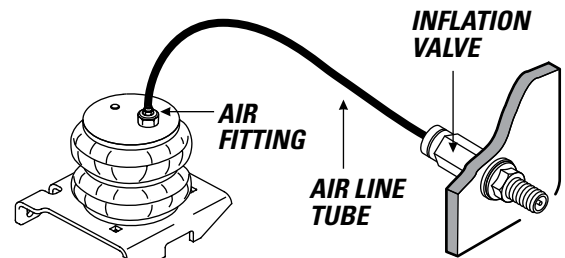

- 1** Place an air chuck onto the Inflation Valve and fill the system to **70 PSI**.

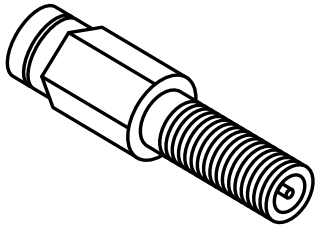

AIR SPRINGS INFLATE QUICKLY. CHECK AIR PRESSURE WHILE INFLATING.

- 2** Spray fittings with soap and water mixture.



- 3** Observe bubbles.

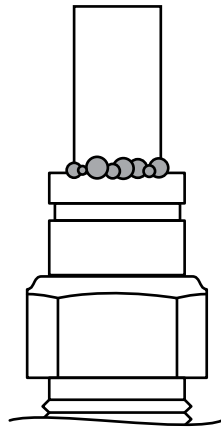

**SMALL SOAP BUBBLES
THAT DO NOT EXPAND**

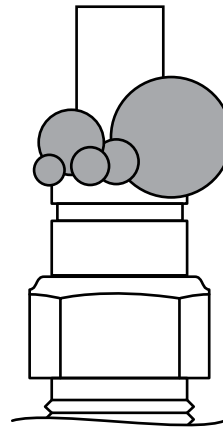

**SOAP BUBBLES
THAT EXPAND**



NO LEAKS?

Congratulations! Continue to Step 15 to finish installation. Review the Operating Instructions.

LEAK?

Bummer. Continue to Step 14 to fix the leak.

14

FIXING AN AIR LEAK

- 1 Press the air valve on end of Inflation Valve to release all air pressure.

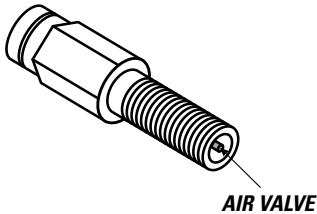

EXHAUST ALL AIR FROM THE SYSTEM PRIOR TO RELEASING AIR LINE TUBES FROM AIR FITTINGS.

LEAK AT AIR LINE TUBE AND AIR FITTING

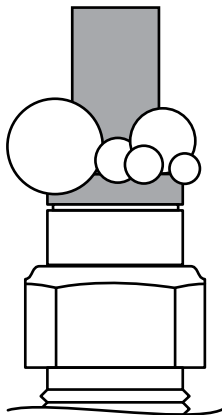

Release Air Line Tube (see page 11). Review proper cuts and procedures in Step 10. Repeat Steps 11 and 13.

LEAK AT BASE OF AIR FITTING ON AIR SPRING

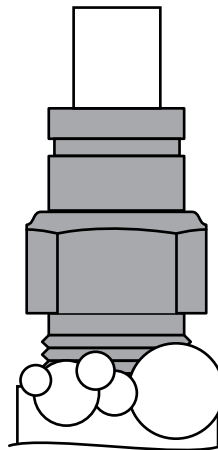

Tighten Air Fitting one turn or until leak stops.

LEAK OUT OF THE VALVE CORE ON INFLATION VALVE

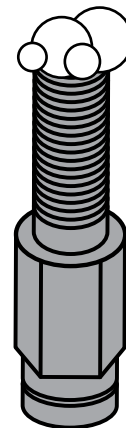

Tighten valve core with valve core wrench on Inflation Valve Cap.

STILL HAVE A LEAK?

Refer to the Troubleshooting section of the Instruction Manual. If the leak persists, or if there is an issue with a leaking part, call 1-800-888-0650; Option 1; Option 1 for Tech Support.

SAFELY RETURN VEHICLE TO OPERATIVE STATE

If you removed any wheels during installation, install the wheels and torque the lug nuts to the manufacturer's specifications.

Safely remove any jack stands and wheel chocks used during installation.

Re-attach the negative battery cable.

DOUBLE-CHECK AIR SPRING CLEARANCE

Check the Air Springs once again for the proper 1/2" minimum clearance. Perform clearance check again when vehicle is under load.

VEHICLE GVWR

NEVER exceed the maximum load recommended by the vehicle manufacturer (GVWR). The GVWR can be found in your vehicle's owner's manual or on the data plate on the driver's side door. Consult your local dealership for additional GVWR specifications.

READ AND UNDERSTAND THE OPERATING INSTRUCTIONS

The Ride-Rite system can improve handling and comfort. Take the time to learn how to properly use and maintain your investment by reading the Operating Instructions.



USE YOUR HAND TO CHECK FOR THE PROPER CLEARANCE AROUND THE AIR SPRING. IF YOUR HAND DOES NOT FIT BETWEEN THE AIR SPRING AND OTHER COMPONENTS, IT WILL RUB!

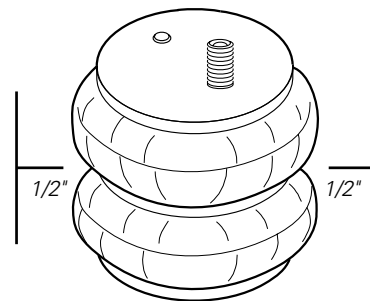

! IMPORTANT

A MINIMUM OF 5 PSI MUST BE MAINTAINED IN THE AIR SPRINGS AT ALL TIMES

Too much air pressure in the Air Springs will result in a firmer ride, while too little air pressure will allow the Air Springs to bottom out over rough conditions, and will not provide the improvement in handling that is possible.



MINIMUM PRESSURE



MAXIMUM PRESSURE (LOADED)



riderite.com

BEFORE YOU DRIVE, CONFIRM THE FOLLOWING:

- Do you have a minimum of 5PSI in your Air Springs?
- Are your Air Springs standing 5 1/2" - 7" tall?
- Are your Air Springs properly aligned, left-to-right and front-to-back?
- Are your nuts and bolts tight?
- Put your paper work back into the sleeve and keep it in your glove compartment for future reference.
- You've been bagged...and now your suspension is Airide™ equipped! Show it off with the supplied decal!

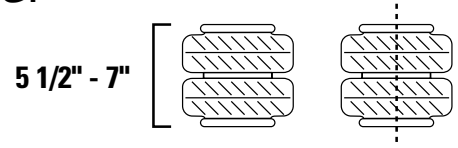

NEED INSTALLATION HELP? 1-800-888-0650

Select Option 1 for Ride-Rite; Select Option 1 for Technical Support.

Or, email us at rrtech@fsip.com. If emailing, please include photos to help us better diagnose and understand any problems you may be experiencing.



CONNECT WITH US



@rideriteair



@rideriteair



Firestone RideRite



Firestone Ride-Rite

COMBO STUD NOTICE:

THE ALIGNMENT PIN ON THE AIR SPRING **MUST** BE INSTALLED INTO THE HOLE IN THE UPPER BRACKET.

FAILURE TO DO SO WILL CAUSE THE ALIGNMENT PIN TO BE PUSHED INTO THE BEAD PLATE, CREATING AN AIR LEAK, AND RESULTING IN AN AIR SPRING FAILURE THAT IS **NOT WARRANTABLE.**

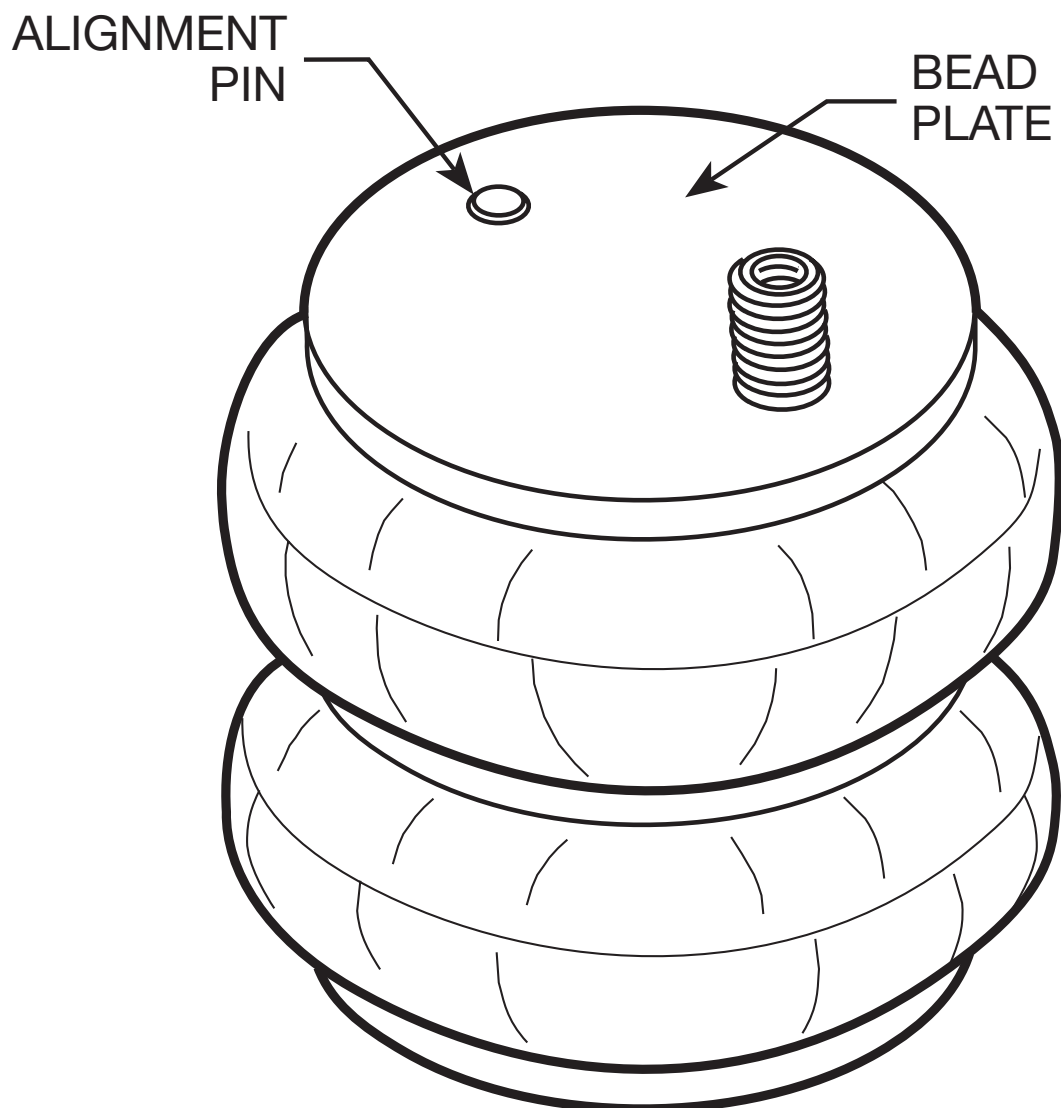

No Drill Inflation Valve Bracket

Parts List

Description	Part Number	Quantity
Inflation Valve Bracket	9483	1
Large Nylon Tie	9488	2

This bracket is designed to mount on receiver hitches round or square. Simply use the two provided large Nylon ties to affix the bracket to the receiver hitch tube. Install the air inflation valves on the bracket using two 5/16" flat washers per valve as supports. Then push the end of each air line tubing into the inflation valve as far as possible.

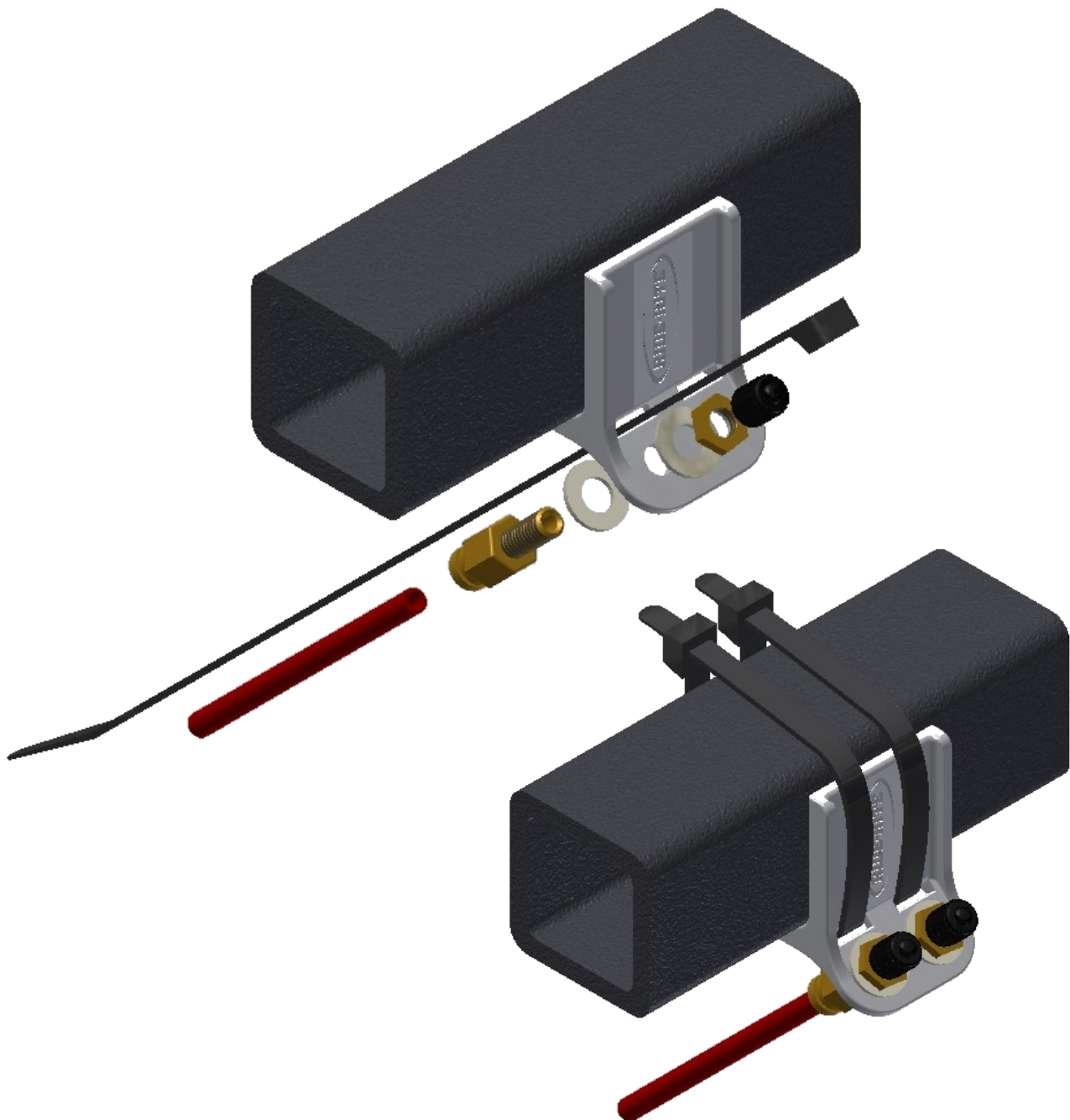

Firestone

**World's Number 1
Air Spring.**



FIRESTONE INDUSTRIAL PRODUCTS COMPANY



Operating Instructions and Trouble Shooting Guide

Thank you for purchasing Firestone air helper springs. You have purchased a quality product from the world's number one air spring manufacturer.

This guide will provide answers to some of your questions regarding the use and operation of your new air helper springs. Following the guidelines in this manual will help provide you with many years of trouble-free service from your Firestone air helper springs.

For vehicle applications, air pressure requirements, air compressor CFM, maintenance, or air spring technical data, contact us at:

www.ride-rite.com
1-800-888-0650

INSTALLER: Please leave this manual with the vehicle's owner.

WARRANTY QUESTIONS

Go to **www.riderite.com/installation-support**
Select "Warranty Info" tab

SAFETY TIPS

Never exceed the manufacturer's recommended Gross Vehicle Weight Rating (GVWR)

As with your vehicle's tires, an air helper spring is a pneumatic device that supports a portion of the vehicle's weight. The air helper spring may fail as a result of punctures, impact damage, improper inflation, improper installation, or improper usage. To reduce the risk of failure, we strongly recommend the following:

Never overload your vehicle. The manufacturer's gross vehicle weight rating (GVWR) is stated on the specification plate on the chassis. You should weigh your vehicle on a truck scale when it is fully loaded and in a level condition to determine if you are exceeding the manufacturer's recommended GVWR.

Inspect the inflated air springs to verify that they do not contact any component of the vehicle under normal suspension operation. The air helper spring must flex and expand during normal operation. There must be at least 1/2" of clearance between the inflated air spring and any other component of the vehicle under normal suspension operation.

The kit is designed to clear all chassis components. If there is **any** interference, please call Firestone at 1 (800) 888-0650.

Inspect the air line tubing and the air spring to verify that they have not been too close to the exhaust system. If the distance between any portion of the air spring or air line tubing and the exhaust system is less than 6", a heat shield should be used.

Never inflate the air helper springs beyond the maximum pressure indicated in the installation manual.

Never attempt to remove any component of the air spring assembly when the air springs are inflated.

If an air helper spring has failed while you are on the road, operate your vehicle at reduced speeds. High speed over rough roads will result in severe bottoming of the air spring and may damage other vehicle components.

Never attempt to drive the vehicle in an unlevelled condition. Failure to level a heavily loaded vehicle may result in excessive body roll and possible damage or injury.

If unidentifiable problems exist with your air helper spring kit, visit Firestone on the web at www.riderite.com or call 1 (800) 888-0650 for technical assistance.

Never cut, weld, or modify the air helper springs or brackets.

Do not use aerosol tire repair products in the air helper springs or a tire patch of any kind on the air helper spring. If there is a hole in the air spring it must be replaced.

GENERAL INFORMATION

Firestone air helper springs are heavy duty, quality air springs designed to supplement your vehicle's existing suspension system. These durable air springs allow you to maximize your vehicle's load carrying capacity through the use of air pressure. Proper installation, use, and operation will provide the maximum service life and performance your air spring kit is capable of delivering. These instructions will help you obtain the maximum benefits available from your air spring kit.

RIDE-RITE™ AIR HELPER SPRINGS

Ride-Rite™ air helper springs are installed between the frame and the suspension of trucks, vans, and motorhomes. Ride-Rite™ air helper springs are capable of supporting loads up to 5000 lbs per pair.*

SPORT-RITE™ AIR HELPER SPRINGS

Sport-Rite™ air helper springs are installed between the frame and suspension of light trucks, and utilize a sleeve-style air spring to enhance the ride when the vehicle is loaded or unloaded. Sport-Rite™ air helper springs are capable of supporting loads up to 3000 lbs per pair.*

LEVEL-RITE™ AIR HELPER SPRINGS

Level-Rite™ air helper springs replace the existing shock absorber with a fully-protected, reversible sleeve air spring paired it with a high-performance Bilstein monotube shock absorber for perfectly matched performance characteristics over the entire operation spectrum. Level-Rite™ air helper springs are capable of supporting loads up to 1000 lbs per pair.*

BASIC OPERATION

As your vehicle is loaded, the stock suspension is compressed under the weight of the load. Your vehicle's stock suspension system has been designed so that it will provide optimum performance and handling with a specific load on the vehicle. When your vehicle is loaded, its performance, handling characteristics, and ride quality may be compromised. As the stock suspension is compressed, the ride may become "mushy", and you may encounter sway and handling problems. As weight is added to the vehicle, the air helper springs become an active part of

*Do not exceed the vehicle's recommended gross vehicle weight rating (GVWR)

the suspension system. As more air pressure is added to the air springs, they will support more weight. You will be able to compensate for a heavy load by adding air pressure to the air springs, thereby reducing sway and handling problems associated with a heavily loaded vehicle.

TABLE "A"	
ALL TORQUE SPECIFICATIONS	
Using a torque wrench, torque the threaded fasteners to the following specifications:	
Fasteners used on studs and blind holes in air springs	15 – 20 ft lbs
Hex nuts installed on carriage bolts	10 – 15 ft lbs
Hex nuts installed on 3/8" hex bolts	28 – 32 ft lbs
Hex nuts and bolts used to secure brackets to frame	28 – 32 ft lbs
Hex nuts installed on U-bolts	15 – 20 ft lbs
Hex bolts securing tapered sleeve style air spring to lower bracket	10 – 12 ft lbs

PREVAILING-TORQUE LOCK NUTS

In order to assure trouble-free operation, your air spring kit includes a variety of self-locking threaded fasteners. Your kit may include prevailing-torque lock nuts. Prevailing-torque lock nuts may be more difficult to install, but will not come loose under normal suspension operation.

THREAD LOCKING COMPOUND

The hex bolts used to secure the air spring to the brackets may have a locking compound applied to the threads. Lock washers are not required when using a fastener with pre-applied thread locking compound. When installing fasteners with thread locking compound, follow the torque recommendations listed in table.

HELICAL LOCK WASHERS

Your air helper spring kit may include helical lock washers. In order to properly use the lock washer, tighten the nut/bolt fastener just enough to flatten the lock washer. Overtightening the fastener may damage the nut or bolt. When using helical lock washers, follow the torque recommendations listed in Table "A".

AIR FITTINGS

Your kit will include one of two types of push-to-connect air fittings: fittings with a thread locking compound pre-applied to the threads or fittings with a Nylon collar in place of the thread locking compound.

The pre-applied thread sealant, thread the air fitting into the air spring and tighten the fitting securely to engage the pre-applied thread sealant.

The Nylon collar, thread the air fitting into the threaded hole on the air spring so that the Nylon collar makes contact with the top of the air spring and then tighten 1/2 turn. No thread sealant is required.

Both types of air fittings allow easy connection between the air fitting and the air line tubing. To install the air line in the fittings, cut the tubing as square as possible using a sharp utility knife or razor blade. Push the air line into the fitting as far as possible. If the tubing must be removed from the fitting, first release the air pressure from the air spring. Push the collar towards the body of the fitting and then pull the tubing out.

PRESSURE DIFFERENTIAL BETWEEN AIR SPRINGS

It is not uncommon to have different pressures between the air springs after the vehicle has been brought to a level condition. If the vehicle is within the manufacturer's recommended gross vehicle weight and you have not achieved a level condition after inflating the air springs to 100 psi, there may be a problem with your stock suspension. The leaf springs may have become fatigued over time or a leaf spring may be fractured. There may be an obstruction in the air system, not allowing the air pressure to reach the air helper springs.

AIR SPRING ALIGNMENT AND HEIGHT

Upon completion of the installation, the air springs should be inspected for proper alignment. Although the air helper springs can function with some misalignment, it is preferred that the air springs be mounted so that they are aligned with as little top to bottom offset as possible.

Check the distance between the upper bracket and lower bracket (design height). The dimensions shown on **Page 5** are a guide to assist in determining the ideal operating height for your air helper springs.

INFLATING THE AIR SPRINGS

With the air helper springs installed on your vehicle and the vehicle sitting on a level surface, visually verify that the vehicle is in a level state. If the vehicle is not level (front-to-back or from side-to-side) it can be brought to a level position by inflating the air springs. Each air spring has a separate inflation valve. To level the vehicle from front-to-back, add air pressure to both air springs in equal amounts. To level the vehicle from side-to-side, add more air pressure to the air spring on the lower side of the vehicle. When inflating the air springs, add air pressure in small quantities, checking the pressure frequently. The air spring requires much less air volume than a tire, and therefore, will inflate and deflate quickly.

WARNING: DO NOT EXCEED THE MAXIMUM PRESSURE AS INDICATED IN THE INSTALLATION MANUAL

LEVELING THE VEHICLE

Check the level of your vehicle visually. If it is not level, either from front to back or from side to side, level it by inflating your air springs. (If your vehicle is equipped with a cab control unit or automatic control system refer to the directions for that device.) There is one inflation valve for each air spring. To level from front to back, add air pressure to both air springs equally. For side to side, add air pressure to the air springs on the side of the vehicle that is low. When adding air pressure to the air springs, remember that they have a much smaller volume of air than a tire so they will inflate much quicker. Add air pressure in short bursts until the vehicle is level. (NEVER EXCEED 100psi IN EACH AIR SPRING.)

MAINTENANCE

It is considered normal for air helper springs to lose some air pressure over time. Normal pressure loss should not exceed 3 – 4 psi per week when the air springs are inflated to 50 psi. If the pressure loss is greater than 3 – 4 psi per week, there may be a leak in the system. Each time you check the pressure in the air springs, you will lose 1 – 3 psi. The air pressure should be checked at regular intervals.

It is recommended that the air pressure be checked according to the following guidelines:

At least monthly intervals during the continuous operation of the vehicle (see above)

When the vehicle is removed from long-term storage

If the air springs are used to assist in leveling an RV or camper on uneven ground, ensure that the vehicle is returned to a level ride height before departing.

The brackets used to secure the air helper spring to the vehicle should be inspected periodically for damage and for loose fasteners. Ensure that the air line tubing is clear of any sharp edges and routed away from the exhaust system. The brackets and air line tubing should be inspected every 6 months. Ensure that the threaded fasteners are torqued to the specifications listed on **Page 3**.

Accumulated sand, gravel, or other road debris on the air springs or brackets should be rinsed away with a garden hose each time the vehicle is washed.

If it is necessary to lift the vehicle by the frame, first release the air pressure from the air springs. This will allow the air springs to extend to their maximum length without being damaged. The uninflated air springs are capable of supporting the weight of the axle when the vehicle is lifted by the frame. After servicing of the vehicle is complete, lower the vehicle to the ground and reinflate the air helper springs to the desired pressure. **NOTE:** On Sport-Rite kits the air helper springs must be aired up to 50 psi and then release the air until the air helper springs are to the desired pressure.

ONLINE AUCTION PURCHASES

Firestone will not replace missing components from any kit purchased through an online auction.

AIR SPRING TECHNICAL DATA

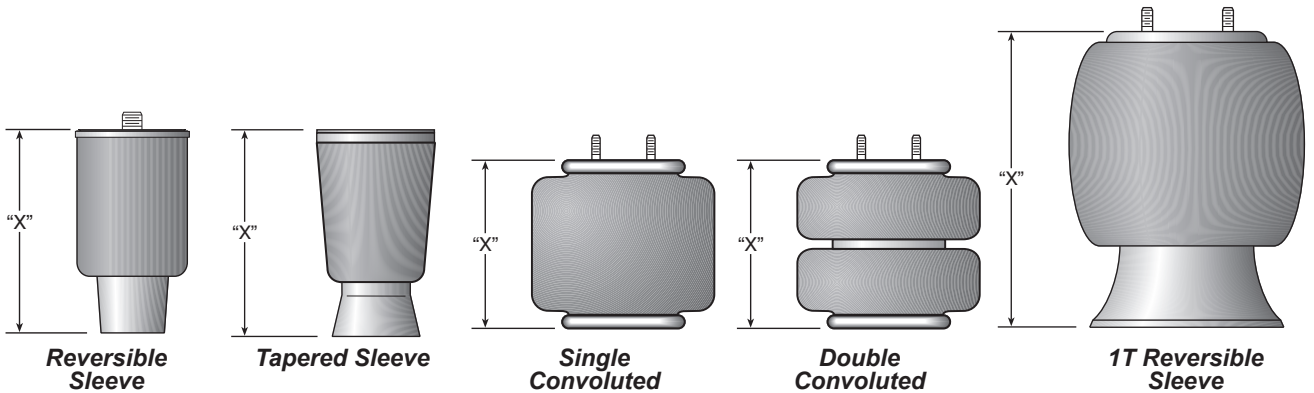



Part Number	Description	Style	"X" Ride Height	Min/Max Air Pressure	Max Load @100 psi (per pair)
6868	Single Convoluted	160BY	5.0" - 6.0"	5 / 100 psi	3600 lbs
6762 6764 6766	Double Convoluted	268C	4.5" - 5.5"	5 / 100 psi	3200 lbs
6397 6410 6781	Double Convoluted	267C1.5	5.5" - 6.5"	5 / 100 psi	4800 lbs
6401 6873 6859	Double Convoluted	224C	5.5" - 7.0"	5 / 100 psi	5000 lbs
7689 7701	Double Convoluted	26C	7.0" - 8.0"	5 / 100 psi	5640 lbs
7076	Reversible Sleeve	70mm	6.0" x 8.0"	10 / 100 psi	2000 lbs
9000	Tapered Sleeve	110/70 mm	7.75" - 8.75"	10 / 100 psi	3000 lbs
9001	Tapered Sleeve	110/70 mm	5.88" - 6.88"	10 / 100 psi	3000 lbs
9002	Tapered Sleeve	110/70 mm	6.75" - 7.75"	10 / 100 psi	3000 lbs
5405	1T Reversible Sleeve	1T14C-3	8.0" - 12.0"	5 / 100 psi	6400 lbs

This information is provided for reference purposes only. The bracketry and air springs in the Ride-Rite™ and Sport-Rite™ kits are designed to work with the original suspension and within the manufacture's Gross Vehicle Weight Rating (GVWR) for the intended vehicle. Brackets and air springs should not be interchanged or modified.

Air Command™ Air Control Systems

Firestone has expanded the offering of Air-Rite™ Air Control Systems, which provides an instant air source for air suspension products. Adjust the ride for various load and road conditions with a flip of a switch or even a click on a remote. Individual air accessory components are also available, including compressors, air tanks and mounting solutions, providing a wide variety of air control assist solutions.

- Step 1** Choose the application you need; Single or Dual Leveling. >>
- Step 2** Choose the style you want to control your air; Analog or Wireless. >>
- Step 3** Choose the Duty Cycle needed for your kit/vehicle. Recommended duty cycle is listed in the Application Guide. >>>

<p>Light Duty</p>	<ul style="list-style-type: none"> • 1-Year Warranty • Includes 9377 Compressor • Best for passenger cars, SUVs, vans, small pickups for occasional use and light loads 	
<p>Standard Duty</p>	<ul style="list-style-type: none"> • 1-Year Warranty • Includes 9284 Compressor • Best for moderate usage, including towing boats, trailers 20' or smaller and medium loads 	
<p>Heavy Duty</p>	<ul style="list-style-type: none"> • 2-Year Warranty • Includes 9499 Compressor • Best for 8-lug trucks, trailers larger than 20', slide-in campers and heavy loads 	
<p>Xtra</p>	<ul style="list-style-type: none"> • 2-Year Warranty • Includes 9499 Compressor • Includes Half-Gallon Air Tank • Includes 9006 Air Hose • Best usage same as Heavy Duty, plus motorcycle tire, golf cart tire or trailer tire inflation 	
<p>Xtreme</p>	<ul style="list-style-type: none"> • 2-Year Warranty • Includes 9287 Compressor • Includes 2-Gallon Air Tank • Includes 2311 Air Hose • Best usage same as Heavy Duty, plus off-road tire or truck tire inflation 	

Single Leveling System

Equal pressure to the springs on both sides. This applies to most towables using a hitch.



Analog

2538

Mounting Plate: **2497**

2158

Mounting Plate: **2497**

2097

Mounting Plate: **2497**

2266

Mounting Plate: **2530**

2543

Mounting Plate: **2530**

Dual Leveling System

Allows for side-to-side or front-to-back leveling. This applies to work trucks, in-bed campers and off-center loads.



Analog



Wireless

N/A

2581

Mounting Plate: **2588**

2178

Mounting Plate: **2497**

2589

Mounting Plate: **2588**

2219

Mounting Plate: **2497**

2590

Mounting Plate: **2588**

2168

Mounting Plate: **2530**

2591

Mounting Plates: **2588/2496**

2549

Mounting Plate: **2530**

2592

Mounting Plates: **2588/2496**

TROUBLE SHOOTING GUIDE

Air spring will not inflate

Ensure that the air line tubing is inserted into the air fittings as far as possible. The tubing should go in the fitting 3/4 of an inch. You will feel some resistance when the tubing goes past the o-ring.

Clear any dirt or debris from inside the inflation valves.

Inspect the entire length of air line tubing to ensure that it is not kinked, damaged from exhaust heat, or cut due to contact with sharp edges

Air spring will not hold air

Normal pressure loss is no more than 3 - 4 psi per week when the air spring is inflated to 50 psi.

Using the inflation valve cap as a core tool, ensure that the valve stem core is installed securely.

Apply a solution of soap and water to the air fittings, air line, and air springs to check for leaks. Tighten the air fitting or re-install the tubing in the air fitting to stop the leak. Rinse the soap and water solution from the system when complete.

If a leak can not be detected with the soap and water solution, deflate the air springs and remove them from the vehicle. Re-install the tubing and inflation valve on the air spring and inflate the air spring to a maximum of 20 psi. Submerge the air spring in a bucket of water to check for leaks.

Locations of air leaks

Leaks occur most often at the threaded connection between the air fittings and the air springs. Tighten the fitting to engage the pre-applied orange thread sealant or until the nylon collar makes contact with the air spring, plus 1/2 turn, depending on which type of fitting is included in your kit. (See air fittings on page 3)

The end of the air line tubing must be cut square and clean to avoid burrs in the connection to the air fittings. The push-to-connect fittings require a square cut to properly seal. The tubing can be removed from the fitting by first releasing the air pressure from the air spring. Push the collar on the fitting toward the body of the fitting. While holding the collar in, pull out the tubing. Cut the tubing squarely and push the tubing into the fitting as far as possible.

The vehicle is not level

Check for proper inflation of the air springs on each side of the vehicle.

Check for obstructions in the air system or vehicle components that may be restricting suspension travel.

IMPORTANT

NYLON TUBE CUTTING:
FOLLOW THESE INSTRUCTIONS
TO AVOID LEAKS

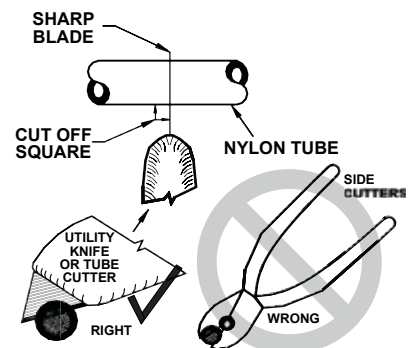



riderite.com

INSTALLATION INSTRUCTIONS

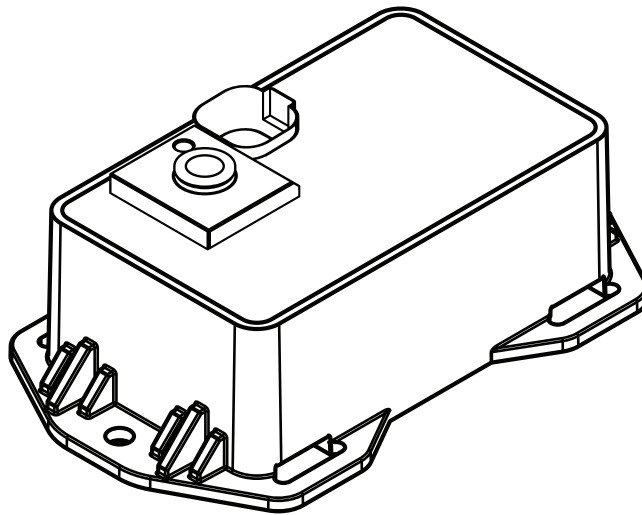

Firestone

Firestone Industrial Products

IMPORTANT

PLEASE DON'T HURT YOURSELF, THE KIT, OR YOUR VEHICLE. TAKE A MINUTE TO READ THIS IMPORTANT INFORMATION.

SAFE INSTALLATION

Please take all safety precautions during installation. A hydraulic jack can fail, and if that happens, you can be seriously hurt, or worse, if you are relying on it to hold up the vehicle. If you use a hydraulic jack, secure jack stands in the appropriate locations and chock any tires still touching the ground.

Wear safety glasses or goggles. Your eyes may be lower than some parts and pieces, and you don't want to lose an eye.

Remove the possibility of any electrical issues by disconnecting the negative battery cable.

VEHICLE GVWR

NEVER exceed the maximum load recommended by the vehicle manufacturer (GVWR). The GVWR can be found in your vehicle's owner's manual or on the data plate on the driver's side door. Consult your local dealership for additional GVWR specifications.

PRESSURE TO LOAD

Be sure to review the load limits noted in the air spring kit installation instructions (sold separately).

APPROPRIATE AIR PRESSURE

For best ride, use only enough air pressure in the air springs to level the vehicle when viewed from the side (front to rear). This will vary, depending on the load, location of the load, condition of the existing suspension, and personal preference.

ONCE INSTALLED SUCCESSFULLY, FOLLOW THESE PRESSURE REQUIREMENTS FOR THE AIR SPRINGS:

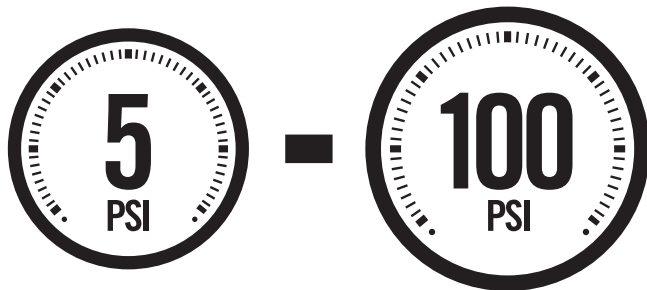



MINIMUM PRESSURE

MAXIMUM PRESSURE (LOADED)

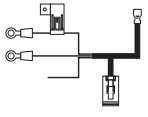
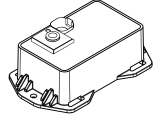
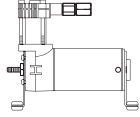

PARTS

Compare the parts below to your kit. Assure you have all pieces, and organize them for an easier installation.









MAIN KIT CONTENTS

PT # 9534	 x1 WIRE HARNESS	PT # 9535	 x1 ECU	PT # 9523	 x1 AIR COMPRESSOR KIT
				PT # 9414	 x1 AIR LINE TUBE (18 FEET)

A24-760-7560 INFLATION VALVE BRACKET KIT

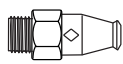
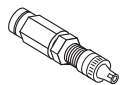
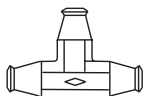
PT # 9483	 x1 NO-DRILL INFLATION VALVE BRACKET	PT # 9488	 x2 LARGE NYLON TIE
-----------	---	-----------	---

A21-760-2610 HARDWARE PACK

PT # 3087	 x4 10-32 x 1" MACHINE SCREW	PT # 3093	 x2 10-32 x 3/4" MACHINE SCREW	PT # 3086	 x10 3/16" FLAT WASHER
PT # 3088	 x6 10-32 NYLOCK NUT	PT # 3055	 x1 1/8 NPT PUSH-TO-CONNECT STRAIGHT FITTING	PT # 3032	 x1 INFLATION VALVE AND VALVE CAP ASSEMBLY
PT # 3025	 x3 1/4" PUSH-TO-CONNECT TEE	PT # 3421	 x1 10-16 x 3/4" SELF-TAPPING SCREW	PT # 9036	 x8 RED NYLON TIE
PT # 9488	 x2 LARGE NYLON TIE	PT # 0899	 x2 THERMAL SLEEVE		

CONTENTS AND OVERVIEW

- PAGE **4** **PLANNING THE INSTALL**

- PAGE **5** **PREPARE THE AIR COMPRESSOR**

- PAGE **6** **DRILL HOLES FOR AIR COMPRESSOR AND ECU**

- PAGE **7** **INSTALL THE AIR COMPRESSOR AND ECU**

- PAGE **8** **INSTALL THE WIRE HARNESS**

- PAGE **9** **INSTALL THE AIR LINE TUBES**

- PAGE **10** **OPTIONAL INFLATION VALVE INSTALLATION**

- PAGE **11** **INSTALL THE AIR FILTER AND CLEAN UP**

- PAGE **12** **CONNECTING TO THE APP**

- PAGE **13** **TEST THE SYSTEM**

- PAGE **14** **FIX AN AIR LEAK**

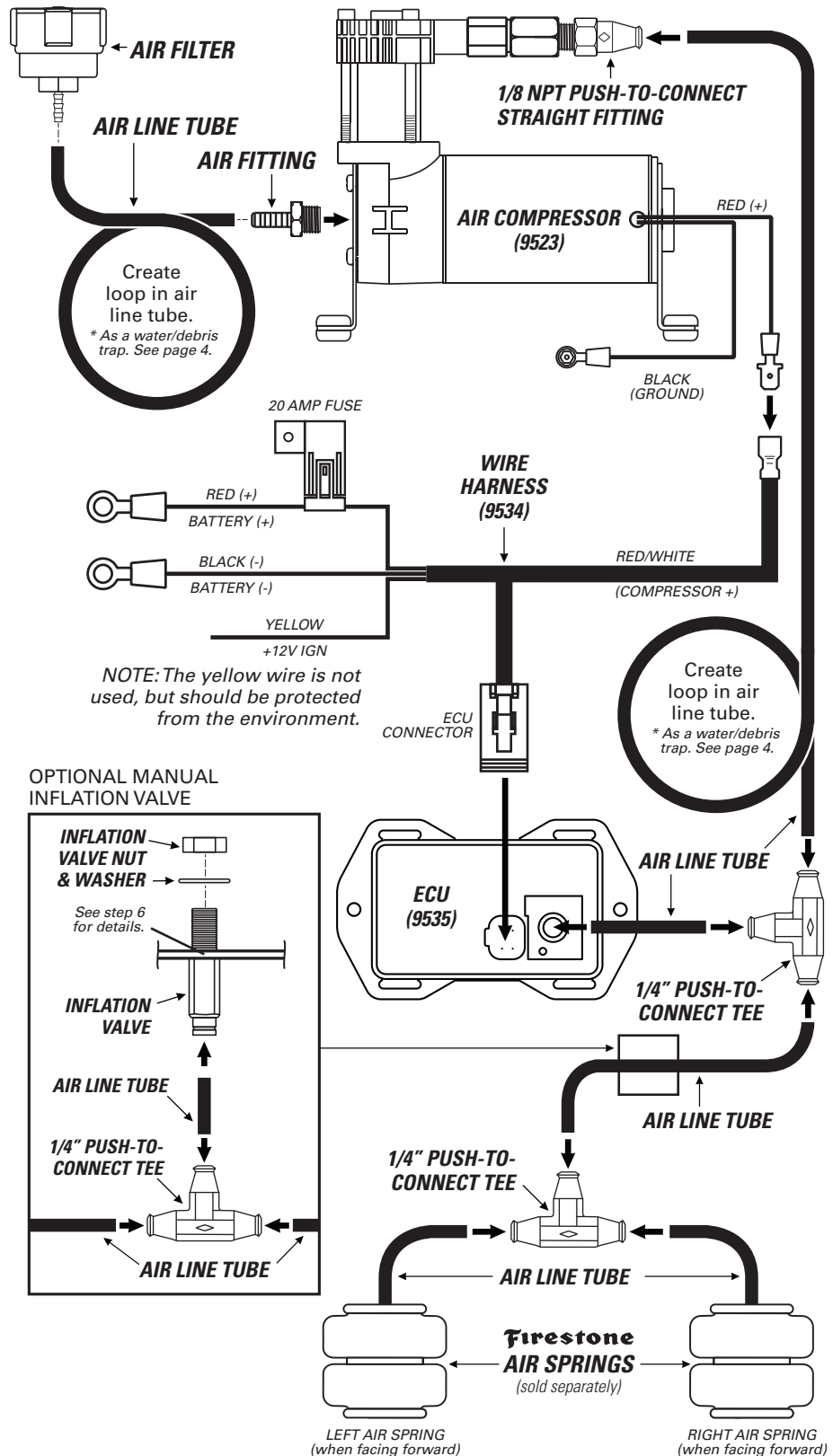

PLANNING THE INSTALL

THESE PLANNING STEPS WILL HELP YOU SAVE TIME AND WILL MAKE THE INSTALLATION EASIER.

DETERMINE THE MOUNTING LOCATION FOR THE AIR COMPRESSOR

- Provides ample air flow and is protected from airborne debris and moisture.
- Mount close enough to the ECU to allow wire harness connections to reach.
- If using the optional Firestone air accessory mounting kit, consider the guidelines above, and follow the kit's instructions.

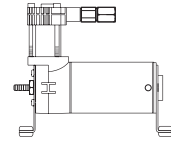

DETERMINE THE MOUNTING LOCATION FOR THE ECU

- Mount close enough to the air compressor to allow wire harness connections to reach.
- Allow room for air line tube to connect to the air fittings on the ECU.
- Allow room for the 4-pin ECU connector to connect to the ECU.
- Allow room for the air line tube to run without sharp curves or bends.
- Using supplied fasteners shown in step 3 is recommended. If no other mounting option is available, see the sidebar on step 2 for using the large Nylon ties.
- Select a location that is solid and secure on the body or frame of the vehicle, away from any moving parts, electrical or any other lines.

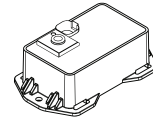

PLAN INSTALLATION ROUTES FOR WIRING AND AIR LINES

- Make sure the wire harness and air line tubes are not exposed to sharp metal edges that can damage them.
- Use supplied thermal sleeves on air line tubes when routing near heat sources.
- Use supplied Nylon ties to secure air line tubes and wire harness to the vehicle.
- Make a loop in the air line tube where shown. This creates a water/debris trap that protects the air compressor.
- Measure twice, cut once!

TAPE ALL ELECTRICAL CONNECTIONS

- Use electrical tape to appropriately secure and protect all electrical connections.

USING PUSH-TO-CONNECT FITTINGS FOR AIR LINES

Your kit includes push-to-connect fittings to connect the air line tubes to hardware. Use the instructions below when using the air line tubes.

- 1** Insert end of air line tube into air fitting.

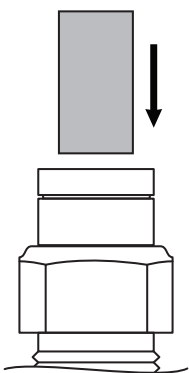

- 2** Push air line tube into air fitting as far as possible.

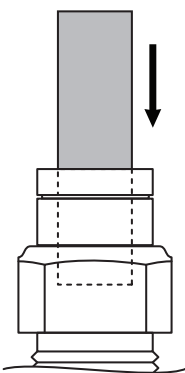

- 3** Gently pull on the air line tube to check for a secure fit.

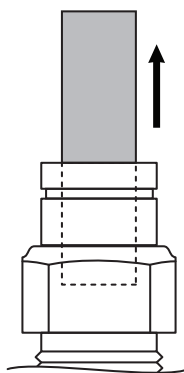

- 4** To remove, push down collar and gently pull air line tube away.

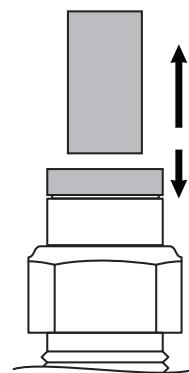

Removal Tip: Use a 1/4", 5/16", or 6mm open-ended wrench to push the collar down.

1

PREPARE THE AIR COMPRESSOR

NOTE: Air compressor can be mounted facing any direction.

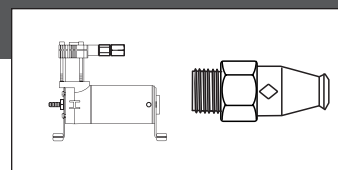

- 1 Install 1/8 NPT push-to-connect straight fitting on the check valve.

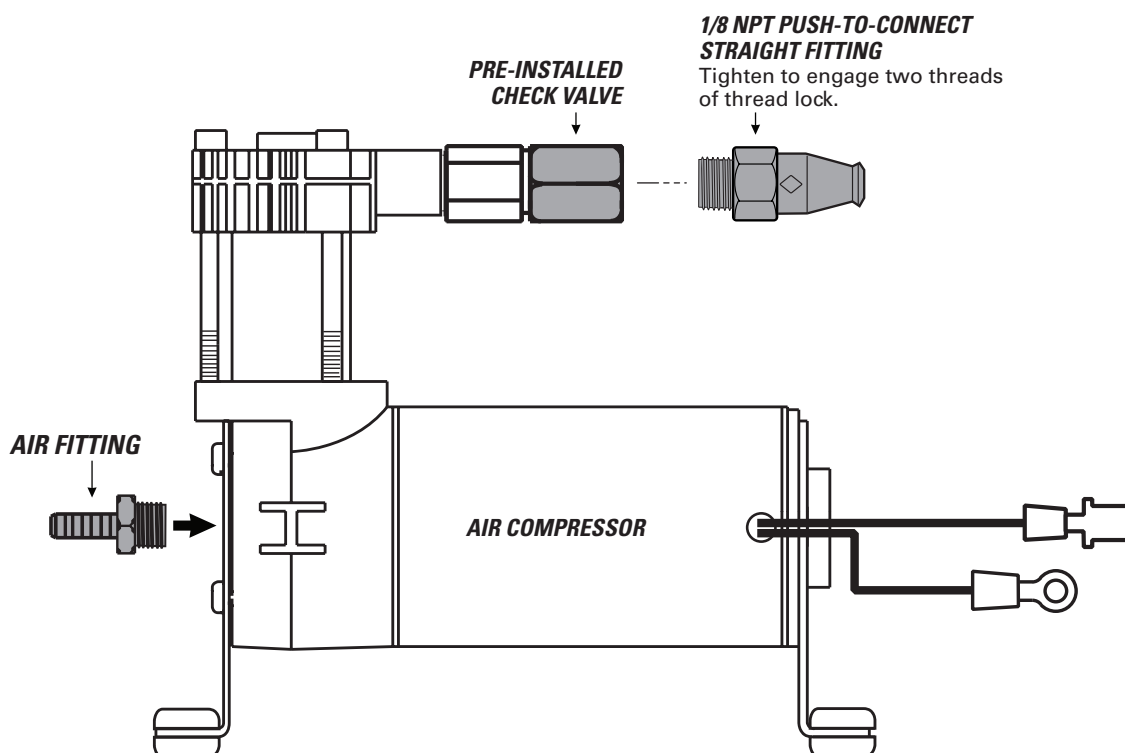

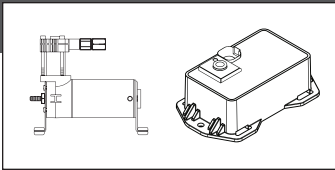

CHECK SURROUNDING AREA AND BACK SIDE OF MOUNTING LOCATION TO AVOID DRILLING INTO EXISTING LINES OR WIRING.



IF YOU ARE USING THE OPTIONAL FIRESTONE AIR ACCESSORY MOUNTING KIT, SKIP THIS STEP AND REFER TO THE MOUNTING KIT'S INSTRUCTIONS.

Drill within reach of the ground wire ring terminal on body or frame of vehicle. **AIR ACCESSORY MOUNTING KIT CANNOT BE USED AS A GROUNDING LOCATION FOR THE AIR COMPRESSOR.**

1 Using the air compressor and ECU as templates, mark drill locations as shown with a punch or marking tool.

2 Mark air compressor ground wire fastening location within reach of the ground wire ring terminal.

3 Drill 3/16" diameter holes. Remove any burrs and debris from drill holes.

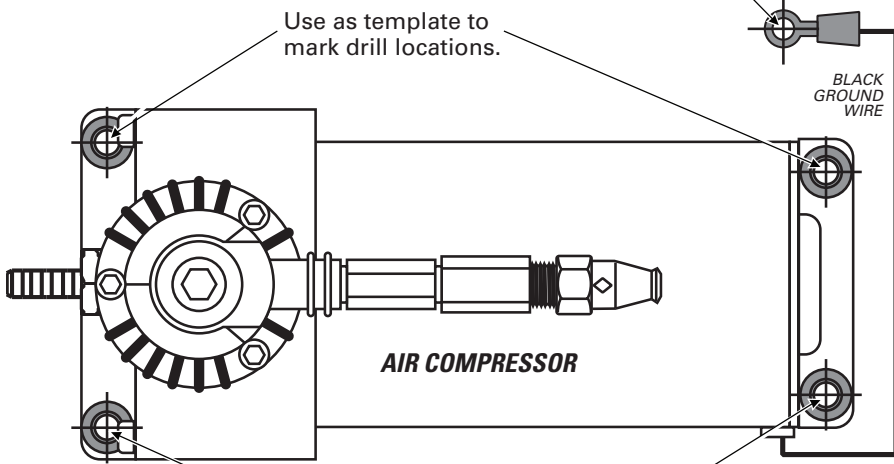

ASSURE THAT YOU INSTALL THE AIR COMPRESSOR AND ECU CLOSE ENOUGH SO THE CONNECTORS ON THE WIRE HARNESS WILL REACH THEM BOTH.

Use as template to mark drill locations.

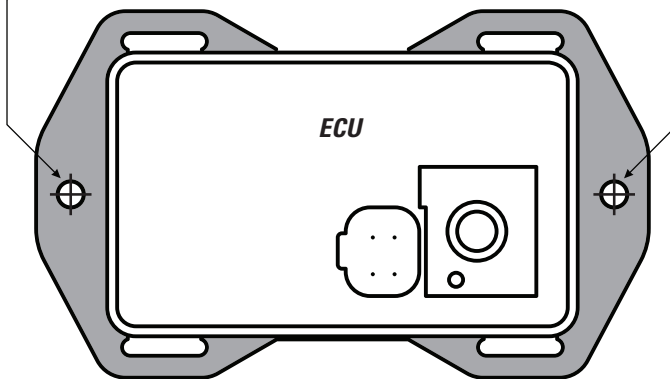

OPTIONAL ECU MOUNTING

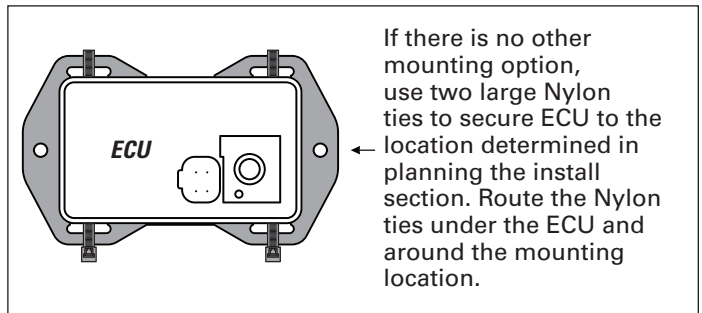

If there is no other mounting option, use two large Nylon ties to secure ECU to the location determined in planning the install section. Route the Nylon ties under the ECU and around the mounting location.

3

INSTALL THE AIR COMPRESSOR AND ECU

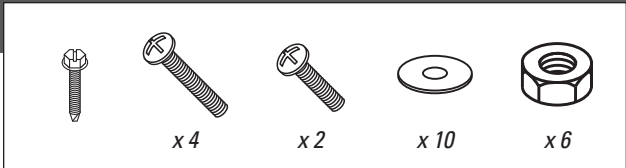

DO NOT OVER TIGHTEN MOUNTING BOLTS AND NUTS ON THE AIR COMPRESSOR. TOO MUCH TORQUE CAN CRUSH THE BRASS INSERTS AND RUBBER ISOLATORS.

1 Mount the air compressor to the drill hole location using the supplied fasteners. DO NOT OVERTIGHTEN.

2 Mount the ECU to the drill hole location using the supplied fasteners.

3 Mount the black ground wire ring terminal using the supplied fasteners. Assure that the ring terminal makes a solid contact with bare metal for a proper ground.

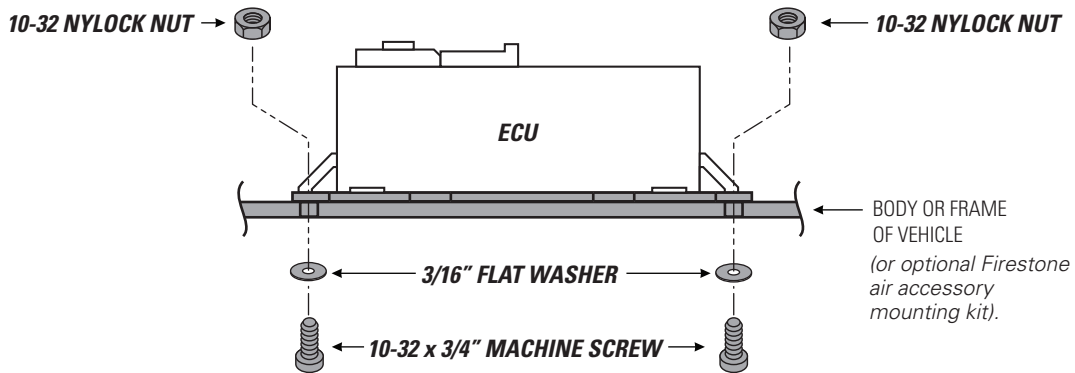
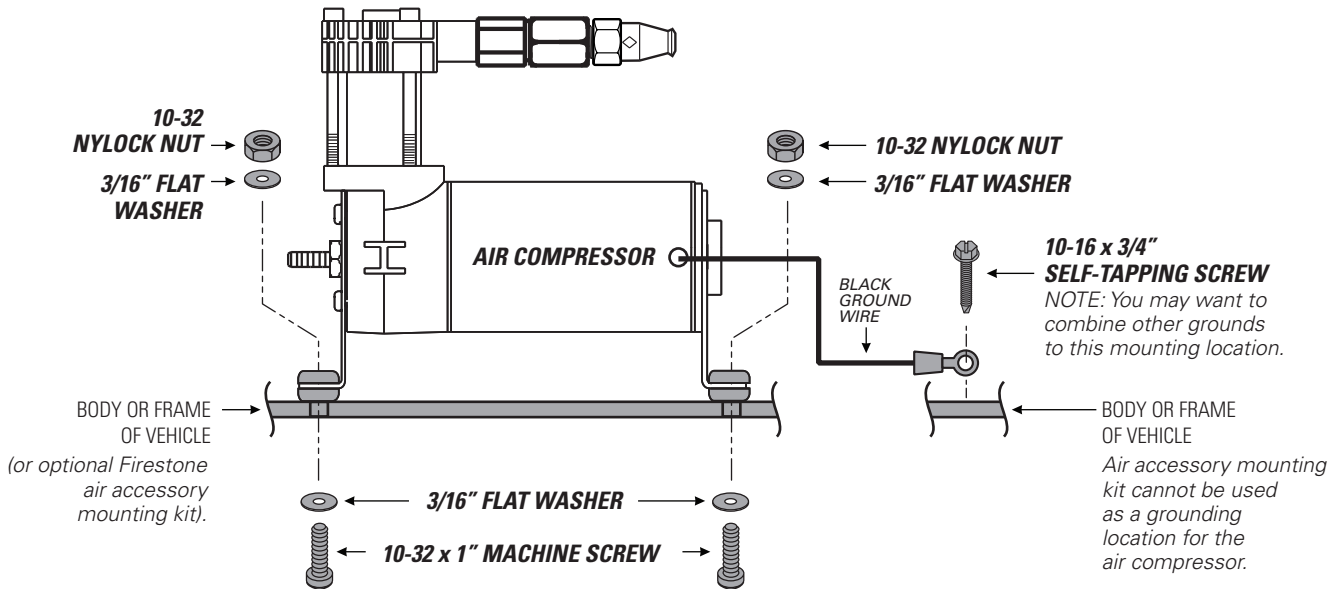

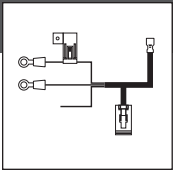

1 Route the wire harness in the most protected manner possible, and securely make all connections as shown.

2 The yellow wire is not used. Wrap or wire nut it to protect it from the environment.

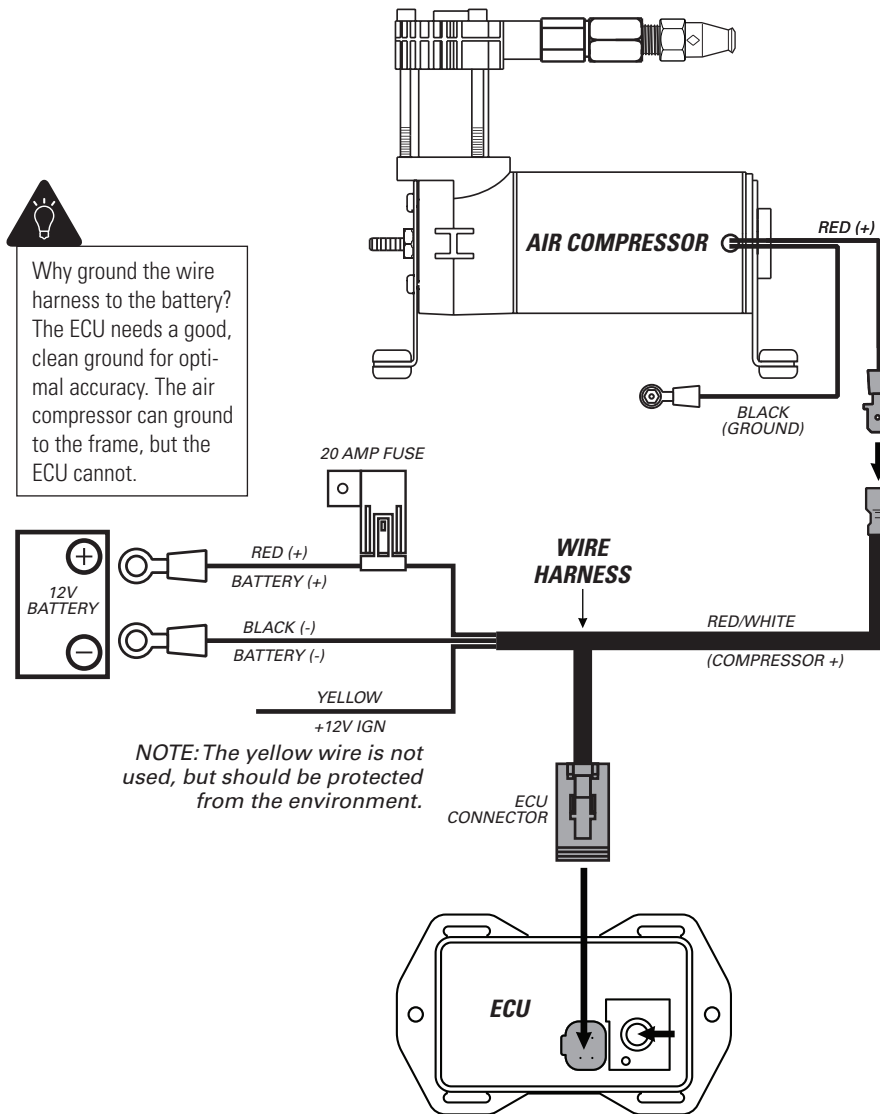

5

INSTALL AIR LINE TUBES



EXHAUST ALL AIR FROM THE SYSTEM PRIOR TO RELEASING AIR TUBES FROM AIR FITTINGS.

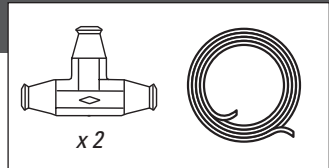

1 Route the air line tube from 1/8 NPT push-to-connect straight fitting on the top of the air compressor to the first 1/4" push-to-connect tee.

2 From the 1/4" push-to-connect tee, route air line tube to the ECU, as shown.

3 Route air line tube from each air spring and connect to a 1/4" push-to-connect tee, as shown.

4 Route air line tube to connect the two 1/4" push-to-connect tees, as shown.

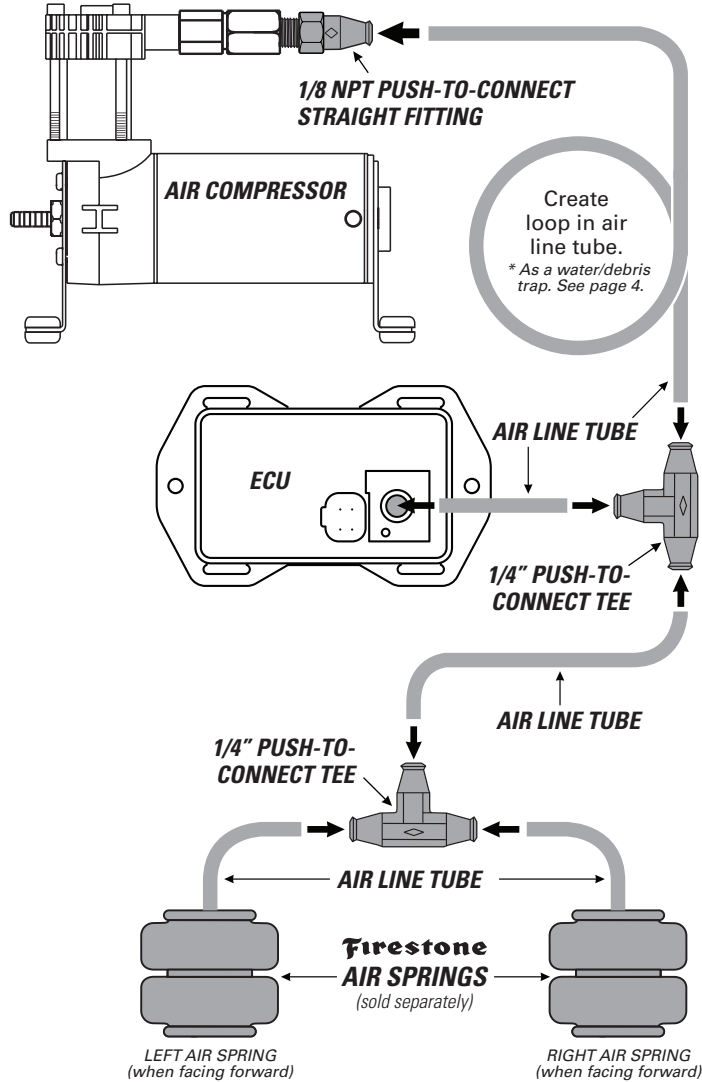

DO

Make sure the cut is as square as possible. Use a tube cutter or very sharp utility knife.

DON'T

Fold or kink the air line tube. Cut the air line tube at an angle. Use pliers, scissors, snips, saws, or side cutters.

PROPER AND IMPROPER CUTS IN THE AIR LINE TUBE

<p>Square cut AIR LINE TUBE 90°</p>	<p>AIR LINE TUBE</p>	<p>AIR LINE TUBE</p>	<p>AIR LINE TUBE</p>
---	----------------------	----------------------	----------------------

OPTIONAL INFLATION VALVE INSTALL

6

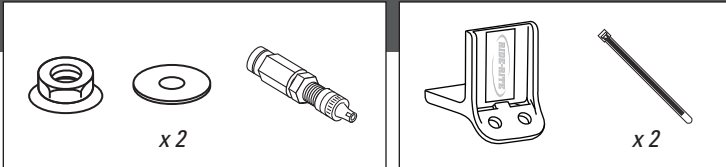

IF USING THE OPTIONAL NO-DRILL INFLATION VALVE BRACKET, CHOOSE OPTION 1. IF DRILLING, CHOOSE OPTION 2. **INFLATION VALVE MUST BE ACCESSIBLE BY AN AIR CHUCK.**

- 1 Secure the air inflation valve bracket to a protected, secure location. **PROCEED TO STEP 3.**

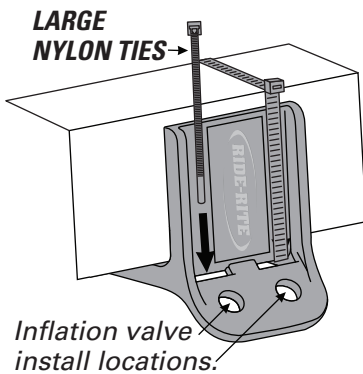

- 2 Select a protected location to install the inflation valve, such as the bumper or the body of the vehicle.

Drill a 5/16" hole for inflation valve install location.

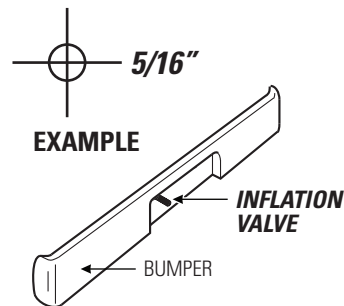

- 3 Install inflation valve assembly as shown.

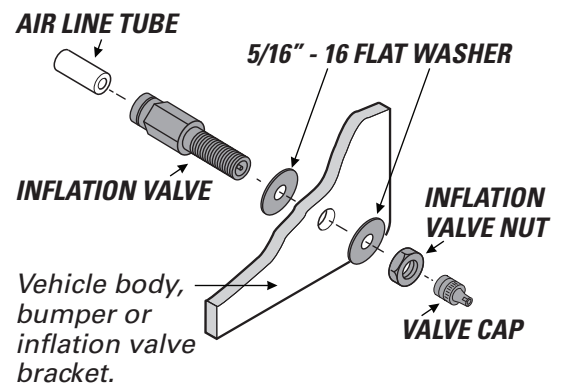

RUN AIR LINE TO OPTIONAL INFLATION VALVE

7

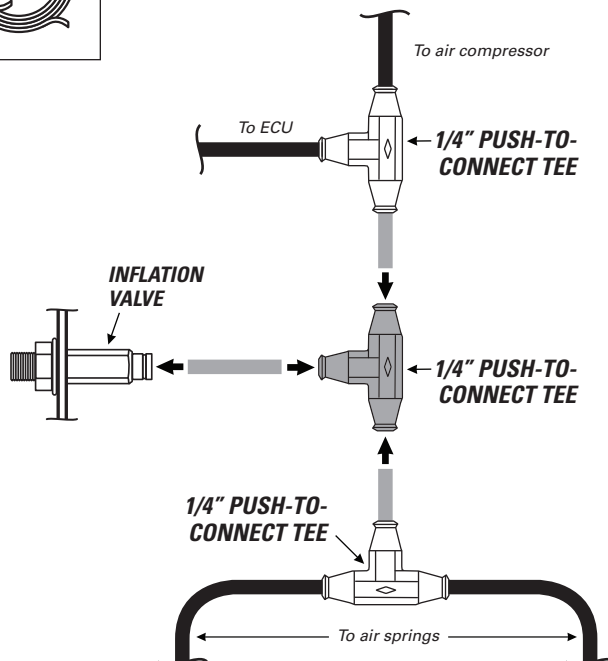
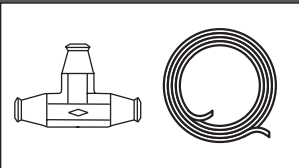

- 1 Run air line tube from the location of the installed inflation valve in step 7 to the air line tube that connects the two installed 1/4" push-to-connect tees.

- 2 Cut the piece of air line tube that connects the two installed 1/4" push-to-connect tees.

- 3 Install the air lines into the 1/4" push-to-connect tee, as shown.

- 4 Install the air line tube into the inflation valve, as shown.

8

INSTALLING THE AIR FILTER

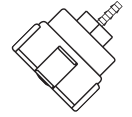

FILTER LIFE WILL VARY BASED ON ENVIRONMENTAL CONDITIONS. PROTECT THE AIR COMPRESSOR BY CHANGING THE AIR FILTER MORE FREQUENTLY IN DUSTY CONDITIONS.

1 Fully secure the air filter barb into the air line tube from the air compressor kit.

2 Press air line tube onto the barb on the air compressor air fitting until fully seated. Assure you create a loop in the air line tube, as shown, when securing it to the vehicle.

3 Periodically check the air filter during operation. When the air filter is dirty and needs to be replaced, contact an Authorized Firestone dealer to purchase a new one.



SECURE THE AIR FILTER IN A LOCATION THAT PROTECTS IT FROM MOISTURE AND DEBRIS, AND IS ABOVE THE LOOP IN THE AIR LINE TUBE.

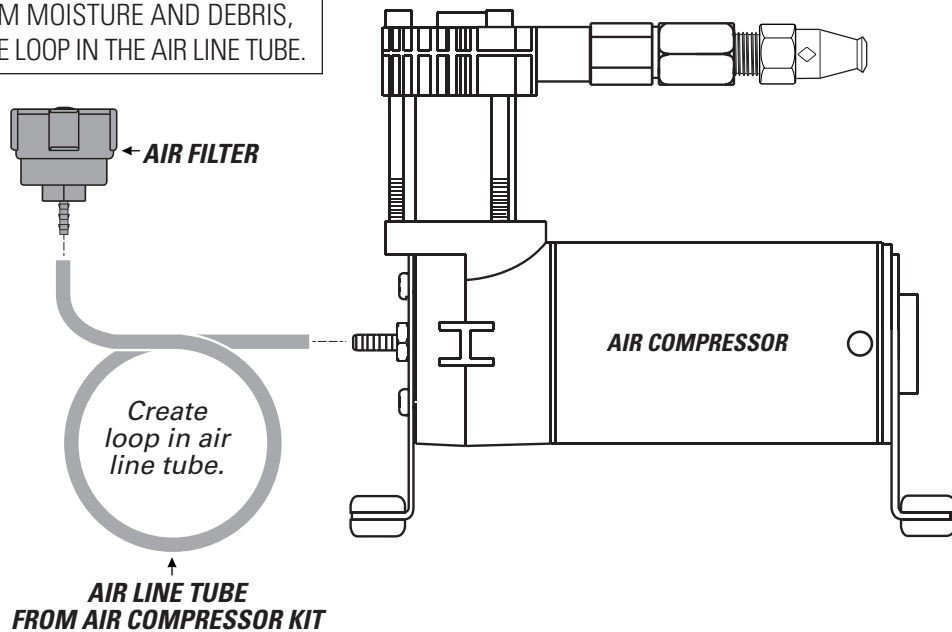

9

CLEAN UP INSTALLATION



1 Clean up the installation using supplied Nylon ties, and return all factory parts and materials to operative state.



USING SUPPLIED NYLON TIES, SECURE ALL WIRING AND AIR LINE TUBE IN A MANNER THAT DOES NOT OBSTRUCT MOVING PARTS OR IN ANY WAY THAT AFFECTS YOUR ABILITY TO SAFELY OPERATE THE VEHICLE.

1 Download and install the Firestone Air Command app on a compatible iPhone or Android device.

2 Open the app. Once the app has established a Bluetooth connection on startup, it will automatically link to the ECU.

MAIN APP SCREEN

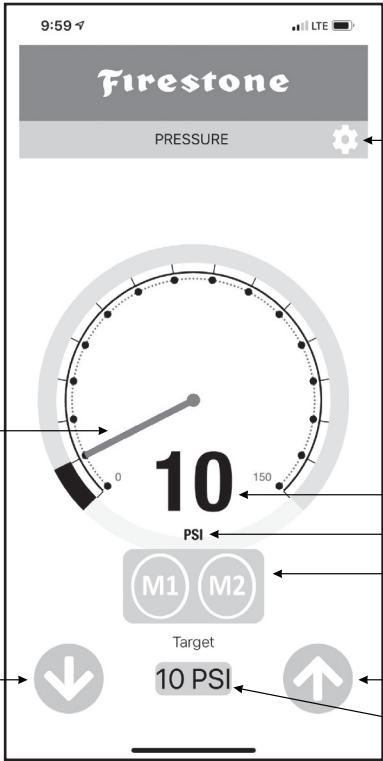

NEEDLE AND BAR
Shows actual pressure. Can be used to change pressure.

DECREASE PRESSURE

SETTINGS

ACTUAL PRESSURE

UNITS

MEMORY BUTTONS
To set memory, hold down target pressure, then press M1 or M2.

INCREASE PRESSURE

TARGET PRESSURE
Set by user.

SETTINGS

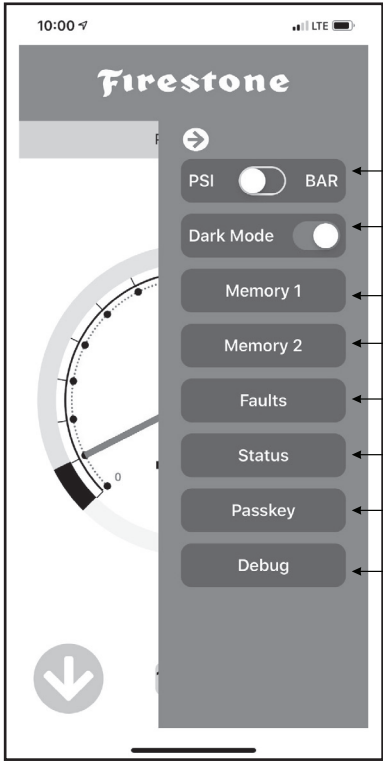

CHANGE UNITS

CHANGE DARK MODE
Auto adjust to ambient light for contrast.

SET AND NAME MEMORY 1

SET AND NAME MEMORY 2

SHOW FAULTS SCREEN

SHOW SYSTEM STATUS SCREEN

CHANGE PASSKEY
User set or default (123456).

SHOW LOG SCREEN FOR TROUBLESHOOTING

* Any faults will include troubleshooting instructions

11

TEST THE SYSTEM

With the Air Command™ F3 kit and your air springs installed, you are ready to test the system.

- 1 Reattach the negative battery cable.

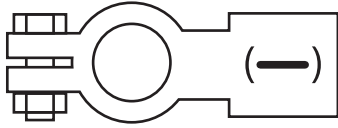

- 2 Turn on your vehicle's ignition.

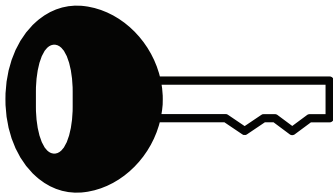

- 3 Use the app to inflate the air springs to 70 PSI. See step 10 for details.

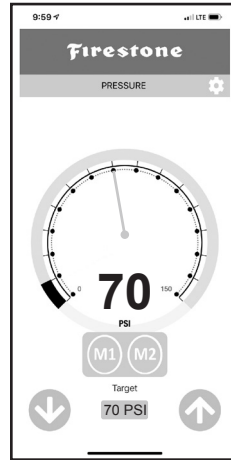

- 4 Spray fittings with soap and water mixture or glass cleaner.



- 5 Observe bubbles.

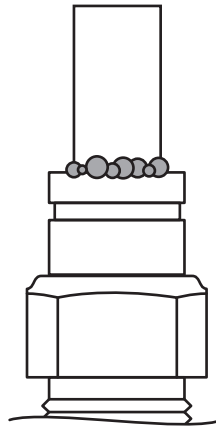

**SMALL SOAP BUBBLES
THAT DO NOT EXPAND**

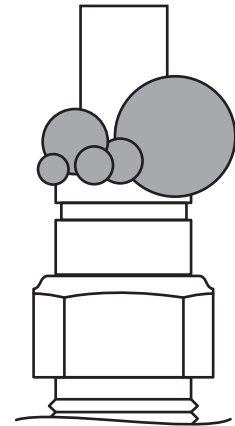

**SOAP BUBBLES
THAT EXPAND**



NO LEAKS?

Congratulations! You're riding right with the push of a button! Remember to review the Operating Instructions.

LEAK?

Bummer. Continue to step 12 to fix the leak.



EXHAUST ALL AIR FROM THE SYSTEM PRIOR TO RELEASING AIR TUBES FROM AIR FITTINGS.



- 1 Use the app to deflate the air springs to 5 PSI. See step 10 for details.

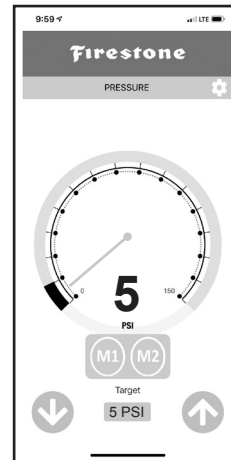

LEAK AT AIR LINE TUBE AND AIR FITTING

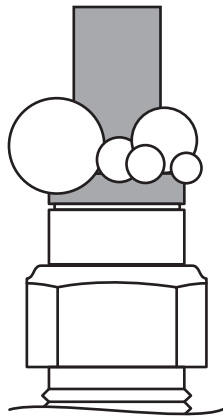

Release air line tube (see page 4). Review proper cuts and procedures in step 5. Repeat step 5.

LEAK AT BASE OF AIR FITTING

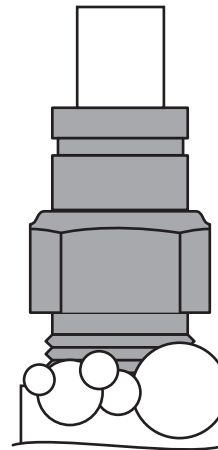

Tighten Air Fitting one turn or until leak stops.

STILL HAVE A LEAK?

Refer to the Troubleshooting section of the Instruction Manual. If the leak persists, or if there is an issue with a leaking part, call 1-800-888-0650; Option 1; Option 1 for Tech Support.



riderite.com

BEFORE YOU DRIVE, CONFIRM THE FOLLOWING:

- Secure all air line tubes and wiring.
- The system passes the leak test and holds air.
- The air compressor ground ring terminal is contacting bare metal, and coated with silicone if possible.
- The wire harness is grounded to the negative (-) battery terminal. The ECU needs a good, clean, interference-free ground.
- There is a loop in the air line tubes as shown to prevent water or debris from getting into the air compressor head and damaging it.

NEED INSTALLATION HELP? 1-800-888-0650

Select option 1 for Ride-Rite; Select option 1 for Technical Support.

Or, email us at rrtech@fsip.com. Please include photos to help us better diagnose and understand any problems you may be experiencing.

Firestone

Firestone Industrial Products

CONNECT WITH US



FirestoneIP



Firestone Ride-Rite