

Installation Instructions:

1. Remove vehicle's existing hub assembly (dust cap, axle snap ring, lock ring, drive flange, spring and oil slinger ring).
2. Set aside removed components.
3. Clean and remove corrosion from wheel housing, paying close attention to locking ring groove.
4. Put a light coat of motor oil on the axle shaft and the wheel housing splines.
5. Insert the Mile Marker body assembly (Item 3) into the wheel housing. Line up the axle splines first, then rotate the outside of the body assembly until the wheel housing splines line up. Slide body assembly in. You may need to lift the axle up slightly to center wheel bearing free play.

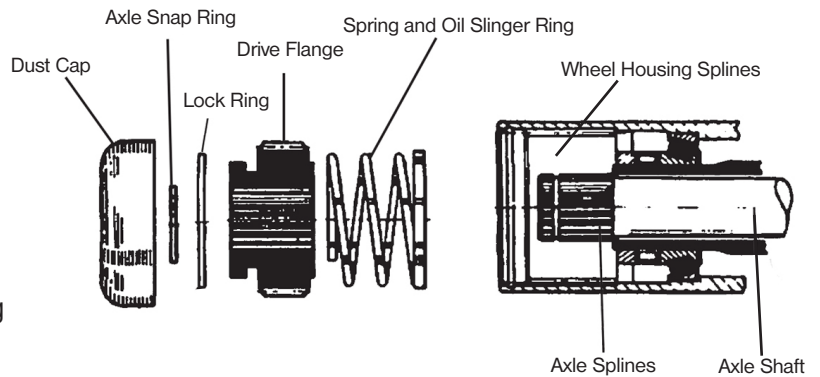

ITEM	DESCRIPTION	PART NUMBER
1	Allen Head Screw	449.14
2	Cap Assembly	449.CAS
3	Body Assembly	449SS
		449.BA
4	Alignment Pin	N/A
5	Lock Ring	449.09
6	Spirolox	105.15

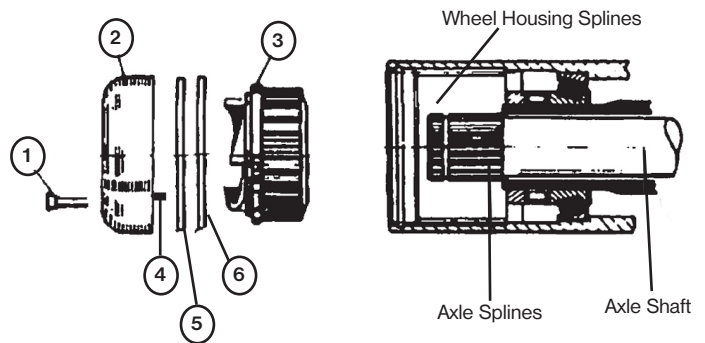

6. Grasp the spirolox (Item 6) and spread it apart with your fingers. Angle the entire lock ring (Item 5) away from face of the body assembly so that the inboard can be inserted into the ring groove in the truck. Maintain the angle and continue to insert the lock ring in a spiral manner until the lock ring is installed. Insert into the groove of the wheel housing. These hold the body assembly into the housing.
7. If axle groove is visible, you can now install the optional factory axle snap ring.
8. Cap Assembly (Item 2) (See diagram on page 2)
 - A) Set the dial on the cap assembly to FREE.
 - B) Place the cap assembly over the opening on the wheel housing. Ensure that the alignment pin is in place.
 - C) Ensure the ends of the cap springs are lined up with the base of the ramps on the cam of the Mile Marker body assembly.
9. Install the six Allen head screws.
10. Turn dial to lock, then back to free, ensuring the assembly moves freely.

Service Instructions:

Hubs should be serviced at same time as wheel bearings. Clean and coat with motor oil. The hubs should never be packed with grease. We recommend checking wheel bearing adjustment and locknut torque to be sure they are within vehicle manufacturer's specifications. We recommend to engage hubs for at least one mile monthly. If the body assembly requires service, disassemble and clean. Put a light coat of bearing grease on the axle gear. When the cam assembly is put back together, ensure it is aligned with the cap screw holes as shown below.

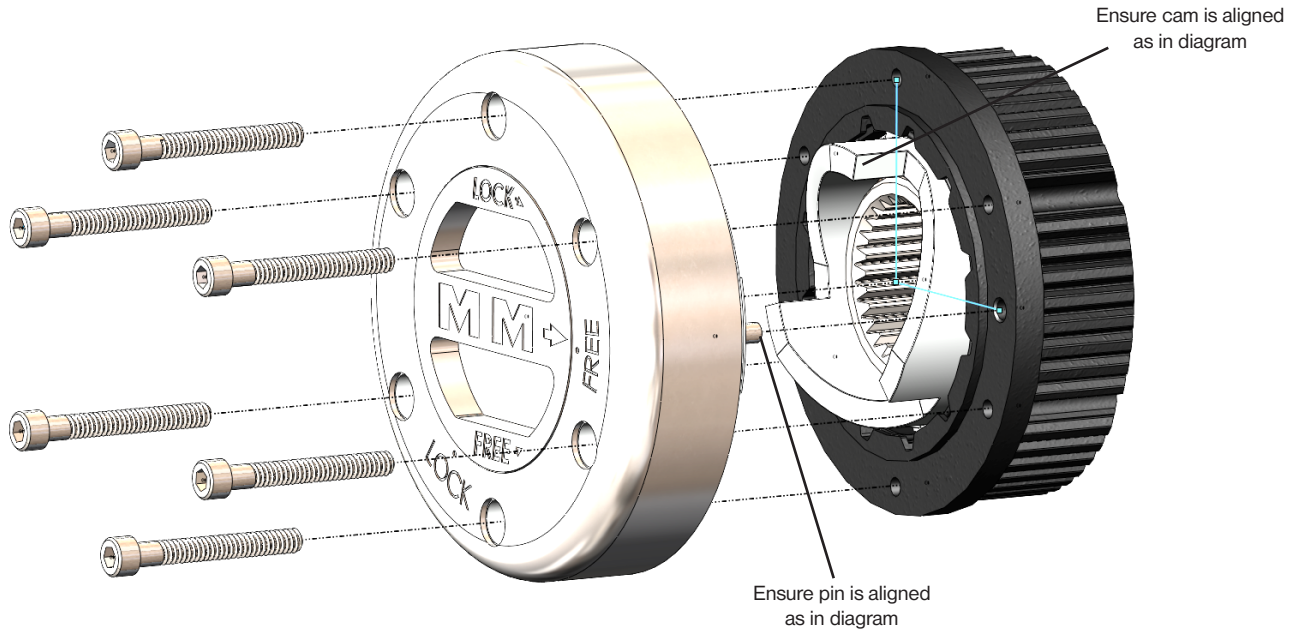

Operating Instructions:

2-Wheel Drive: Both control dials set in FREE position and transfer case in 2-wheel drive.

4-Wheel Drive: Set both hubs to lock and shift transfer case to 4-wheel drive. DO NOT drive on pavement or other hard surface roads in LOCK, this can result in severe binding up and damage of the gear train.

Never drive with one hub only engaged, as this can damage the front differential.

Never drive unless the control dials are in either fully locked or fully free position. If the hubs are partially engaged, hub damage may result.

Warranty Information:

Mile Marker Industries warrants directly to the first purchaser that Mile Marker Locking Hub Part Numbers 104, 302, 420, 423, 430, 432, 435, 449SS, 459SS, 457, 466, 470, 481, and 490 will be free from defect in material and workmanship appearing under normal use and service for as long as said purchaser owns the locking hub. Warranty registration cards for each product must be submitted within 30 days by the end user, or online at www.MileMarker.com/warranty. If you discover a hidden defect, Mile Marker will, as its option, repair or replace the product or necessary replacement parts at no charge to you, provided you remove the product from the vehicle and return it prepaid to Mile Marker Industries. If the product was purchased in the United States, the owner must contact our warranty department to get a Return Goods Authorization (RGA) number before returning the product. If the product was purchased outside the United States, the owner must return the product to the original place of purchase.