

Installation Manual



10171-X KIT

GMC/Chevrolet 2500 & 3500 2WD/4WD*
(With or Without 5th Wheel Hitch)

Eliminate your vehicle's sag, sway and bottoming out while providing added support for an overall smooth and safe ride with this extreme duty air suspension kit. Rated for up to 7500 lbs of load-leveling capacity⁺, this kit is ideally suited for those towing/hauling big loads on a regular basis.

* See application guide for proper fitment.

+ Applications vary. Never exceed manufacturer's recommended Gross Vehicle Weight Rating



WARNING: This product can expose you to the chemical Hexavalent Chromate, which is known to the State of California to cause cancer and birth defects or other reproductive harm. *For more information go to www.P65Warnings.ca.gov*

IMPORTANT

This air suspension kit will not increase the GVWR (*Gross Vehicle Weight Rating*), as the GVWR is determined by the vehicle manufacturer. **Do not exceed the maximum capacity listed by the vehicle manufacturer.**

Safety Warning!

Serious personal injury or death may result from an air spring failure or accident due to improper installation or air spring pressure operation or maintenance. Please read and abide the instructions, safety recommendations and maintenance suggestions throughout this manual.

Safety Warning!

Inflating an unsecured air spring is dangerous. If it bursts, it could be hurled into the air with explosive force resulting in serious personal injury or death. Never inflate an air spring unless it is secured to the vehicle.

Safety Warning!

Removing and replacing air springs can be dangerous. This is only a job for a qualified service professional. Never perform air spring service procedures without proper training, tools, and equipment.

KIT CONTENTS

Reference the kit explosion diagram on the following page for part assembly.

KIT CONTENTS			QTY	PART #	REQUIRED TOOLS
A	Extreme Duty Air Bag	2	HP10068-X	<ul style="list-style-type: none"> • Hoist or Floor Jack • Safety Stands • Safety Glasses • Torque Wrench • Standard Combination Wrenches • 7/32" Hex Allen Wrench • 1-1/8" Wrench or Deep Socket • Ratchet • Metric & Standard Sockets • Hose Cutter (included) or Sharp Utility Knife • Pipe Thread Sealant • Spray Bottle with Dish Soap/Water • Air Compressor/Compressed Air Source (to test/fill air springs) 	
B	Roll Plate	4	HP10069		
C	Upper Left Bracket	1	HP1655		
D	Upper Right Bracket	1	HP1656		
E	Lower Bracket	2	HP1657		
F	Axle Strap	2	HP0128		
G	5/8" Adel Clamp	1	HP1006		
H	Bolt, 3/8" – 24 X 7/8" Countersunk	8	HP1008		
I	Bolt, 3/8" – 16 X 1.25" Self-Threading	4	HP1078		
J	Bolt, 3/8" – 16 X 3.5" Carriage	4	HP1332		
K	Bolt, 3/8" – 16 X 1.25" Hex Head	1	C10464		
L	Bolt, M8 X 1.25 X 10 mm Hex Head	4	HP1334		
M	U-Bolt, 4.25" X 6.5" Square	4	HP1331		
N	Washer, 3/8" Flat	12	C653		
O	Washer, M8 Flat	4	C10473		
P	Nut, 3/8" Nylon Lock	13	HP1000		
Q	Heat Shield	1	HP0012		
R	Worm gear Ring Clamp	2	HP1001		
S	Fitting, 90° Brass	2	HP1245		
T	Airline Hose Assembly	1	HP1344		
U	Tie Strap	6	C11618		

Please make sure all the items shown in this explosion diagram are provided in your kit before starting the installation.

DRIVER SIDE ASSEMBLY SHOWN:

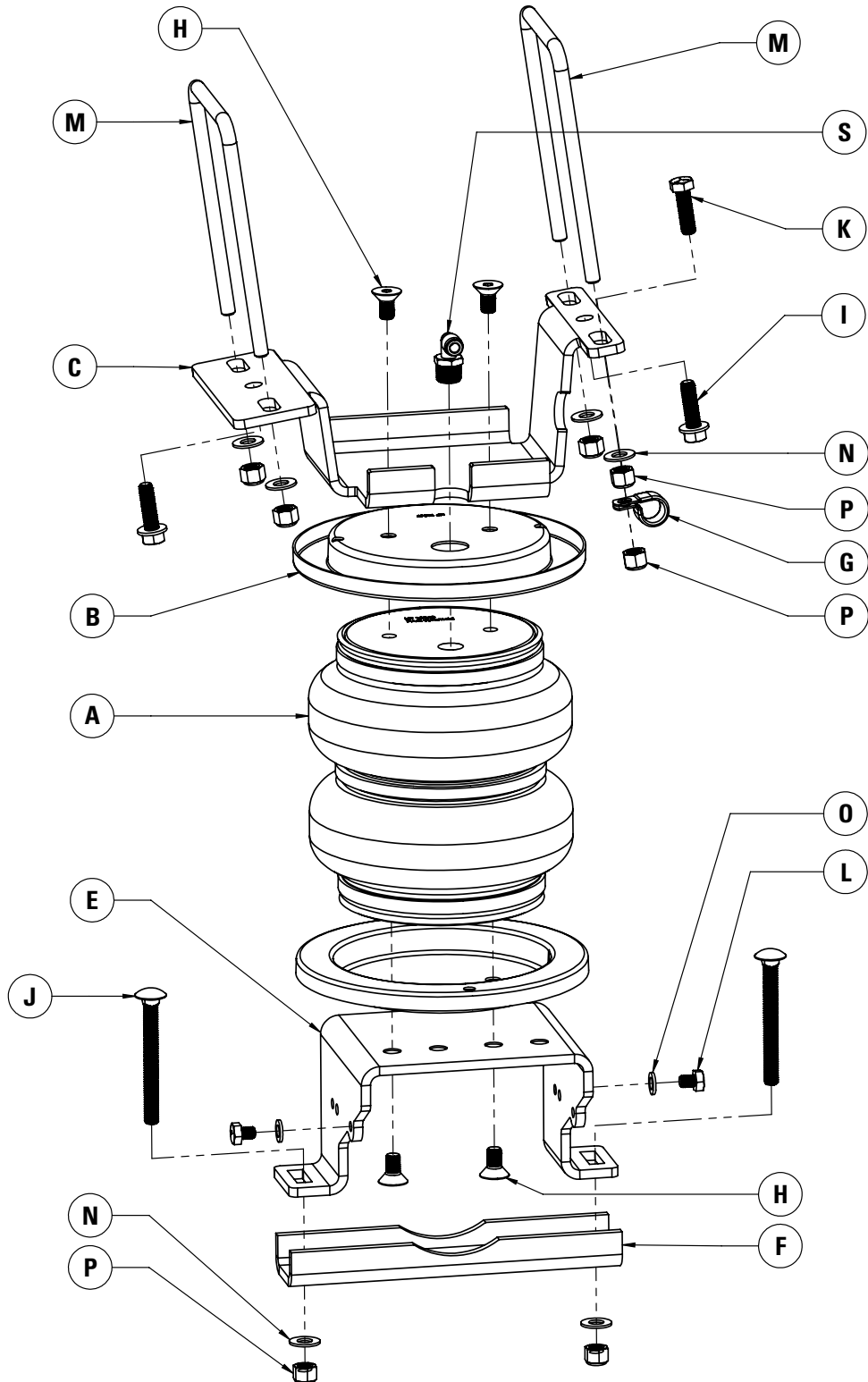

BEFORE STARTING THE INSTALLATION:

1. Ensure the application information is correct for the make, model and year of the vehicle you are installing the kit on.
2. Some vehicles are equipped with a rear wheel brake proportioning valve. Check with the manufacturer before installing the air spring kit, as it may affect braking performance.
3. It is recommended to use a good quality anti-seize on all fasteners. This will reduce the chance of corrosion on the fasteners and will help facilitate removal, if required at a later date.

PLEASE NOTE:

This kit contains push-to-connect fittings; using scissors or wire cutters to cut the nylon airline will distort the line and cause the connection to leak. THE AIRLINE MUST BE CUT OFF SQUARELY WITH THE NYLON HOSE CUTTER PROVIDED IN THIS KIT OR A SHARP UTILITY KNIFE.

1 MEASURE STOCK RIDE HEIGHT

Park the vehicle on a level surface. Remove any unnecessary weight from the vehicle to attain a Normal Ride Height. This is important for correct initial air spring set-up and adjustment.

Using a measuring tape, measure the distance between the center of the wheel hub and the bottom of the fender well (as shown in Figure 1) this will give you your ride height.

Note the ride height for all four corners.

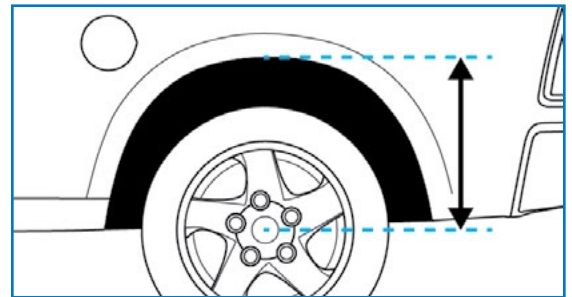

1

2 REMOVE REAR WHEELS

Place wheel chocks in front of and behind both front wheels.

Raise the rear of the truck high enough to remove both wheels and attain a comfortable working height.

Place two jack stands under rear axle (shown in Figure 2).

Lower the vehicle until the axle is supported by the jack stands.

Remove rear wheels.



2

3 REMOVE JOUNCE BUMPERS

Remove the jounce bumpers by prying them out of the retaining cup. A pry bar or large flat screwdriver is typically required.

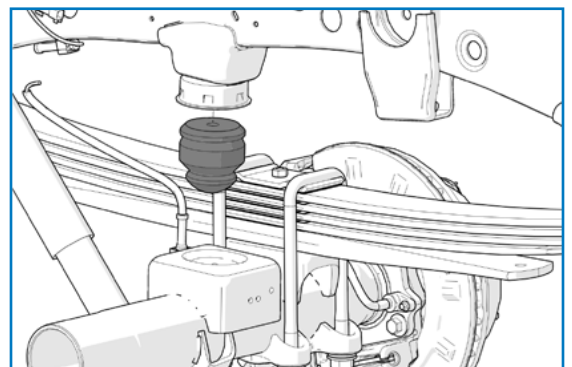

3

4 PRE-ASSEMBLE AIR SPRINGS

Install the 3/8" NPT threaded fittings in the fill opening of each air spring. Tighten finger tight plus an additional 1.5 turns. The use of thread sealant or Teflon tape is recommended.

Place a roll plate and the upper bracket on the top surface of the air spring (see Figure 4A for assembly reference). Align the holes in the air spring, roll plate and bracket and secure with two 3/8" – 24 X 7/8" countersunk screws.

Torque screws to 20 ft-lbs (27 N•m)

Place a roll plate and lower bracket on the bottom surface of the air spring.

Align the lower bracket holes (as indicated with arrows in Figure 4B) to create the respective driver & passenger side assemblies.

Secure with two 3/8" – 24 X 7/8" countersunk screws and torque to 20 ft-lbs (27 N•m).

The finished assemblies should appear as shown in Figure 4C.

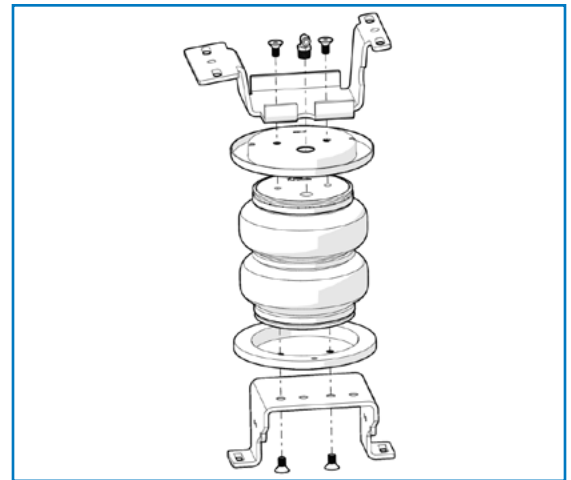

4A

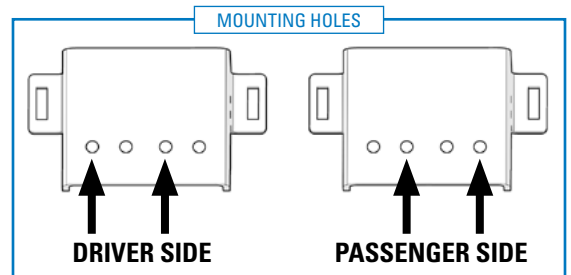

4B

5 REMOVE DRIVER SIDE E-BRAKE BRACKET

Remove the M8 hex cap screw retaining the emergency brake cable bracket to the frame on the driver side. (Shown with an arrow in Figure 5)

Discard the bracket and screw as they will not be reused in this installation.

6 UNSCREW BRAKE LINE BRACKETS

Remove the M8 hex cap screws retaining the brake line to the jounce bumper stops. (Shown with an arrow in Figure 6 on following page)

Discard the screws as they will not be reused in this installation.

7 UNSCREW PASSENGER SIDE E-BRAKE BRACKET

Remove the hex cap screw retaining the emergency brake cable to the jounce bumper stop on the passenger side of the vehicle. (Shown with an arrow in Figure 7 on following page).

Discard the screw as it will not be reused in this installation.

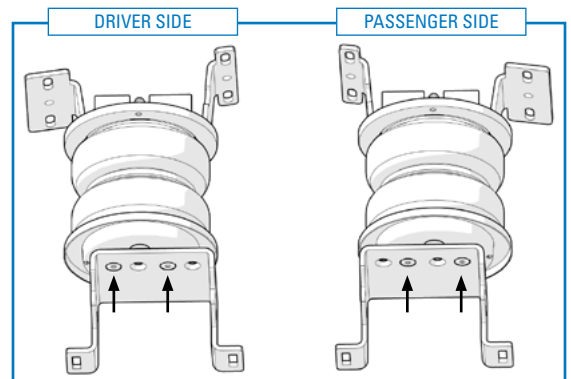

4C



5

8 INSTALL AIR SPRING ASSEMBLIES

NOTE: It may be necessary to raise the frame of the truck a few inches to allow more clearance to install the spring assemblies

Position the air spring assembly such that the lower bracket rests on the jounce bumper stop and the upper bracket nests around the jounce bumper retaining cup with the air fitting pointing inwards (see Figure 8A for reference).

Insert two 3/8" – 16 X 3.5" carriage bolts through the rectangular holes in the lower bracket. Install the axle strap (as shown in Figure 8B) with two 3/8" flat washers and two 3/8" nylon lock nuts.

Do not fully tighten yet.

9 INSTALLATION FOR TRUCKS WITHOUT A 5TH WHEEL HITCH

Secure the upper bracket to the frame (as shown in Figure 9A on the following page) using two U-bolts with four 3/8" flat washers and four 3/8" nylon lock nuts.

Ensure no wires or brake lines are pinched between the frame and U-bolt during install.

Align the air spring by adjusting the brackets on the frame and axle to achieve the best vertical alignment (reference Figure 9B on the following page for correct air spring alignment).

Evenly torque the nylon lock nuts on the upper bracket and axle strap to 20 ft-lbs (27 N•m).

On the Driver's Side, secure the emergency brake cable removed in Step 5 to the upper bracket with an adel clamp.

Attach the adel clamp to the forward U-bolt with a second nylon lock nut and torque to 20 ft-lbs (27 N•m).

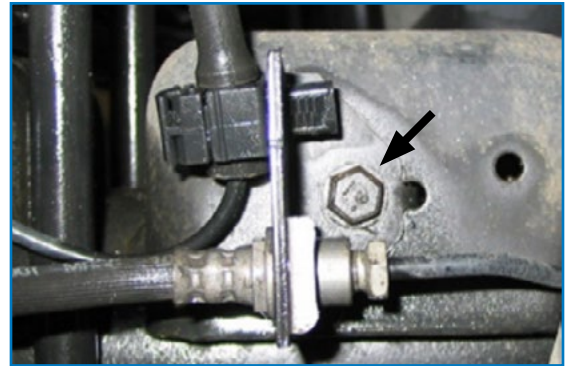

6



7

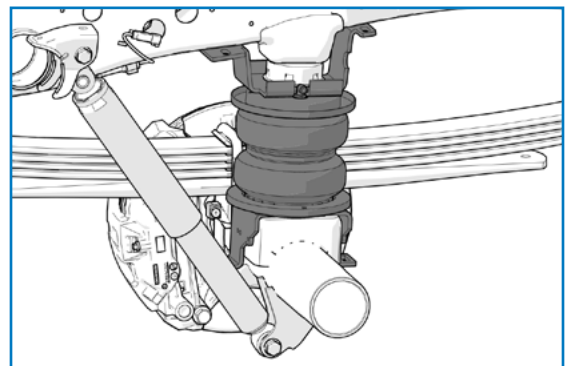

8A

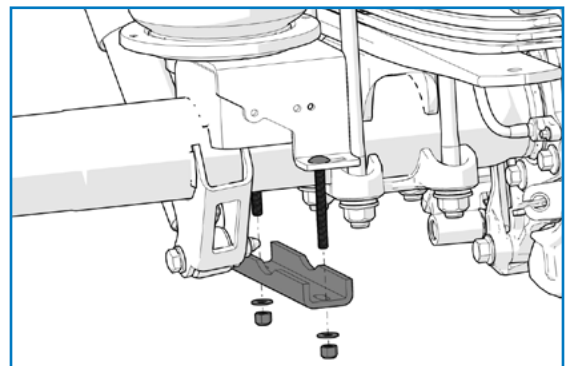

8B

10 INSTALLATION FOR TRUCKS WITH A 5TH WHEEL HITCH

Secure the upper bracket to the frame (using figure Figure 10 as reference).

First, align the air spring by adjusting the brackets on the frame and axle to achieve the best vertical alignment (see Figure 9B for correct air spring alignment).

Using the center holes in the upper bracket flanges as a reference, drill two 5/16" holes into the bottom of the frame.

Secure the upper bracket to the frame using two 3/8" – 16 X 1.25" self threading bolts and torque to 20 ft-lbs (27 N•m)

On the Driver's Side, secure the emergency brake cable removed in Step 5 to the upper bracket with an adel clamp. Attach the adel clamp to the forward upper bracket slot with a 3/8" – 16 X 1.25" bolt and 3/8" nylon lock nut.

Torque bolt to 20 ft-lbs (27 N•m).

11 REATTACH BRAKE LINES

Using the M8 X 1.25 X 10 mm Hex bolts, attach the brake line brackets removed in Step 6 to the rear face of the lower brackets as shown in Figures 11A & 11B.

Torque bolts to 12 ft-lbs (16 N•m)

On the Passenger Side, attach the emergency brake cable bracket to the front face of the lower bracket with a M8 X 1.25 X 10 mm Hex bolt. (See Figure 11C)

Torque bolt to 12 ft-lbs (16 N•m)

12 INSTALL HEAT SHIELD

Bend tabs on the heat shield so the required 1/2" of dead space exists between the heat shield and exhaust when attached.

Attach the heat shield to the exhaust pipe on passenger side using two ring clamps (shown in Figure 12 on the following page).

Each hose clamp holds a tab against exhaust pipe.

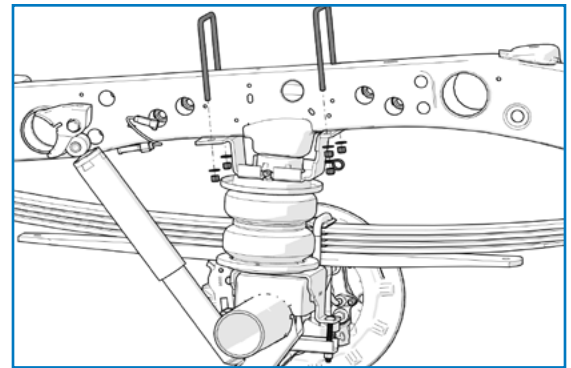

9A

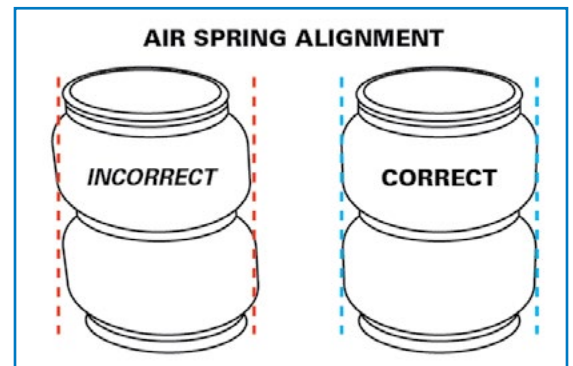

9B

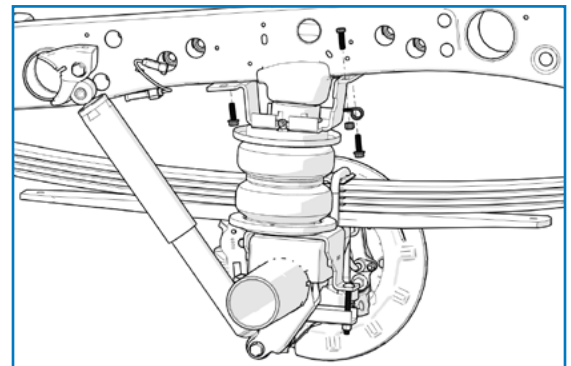

10

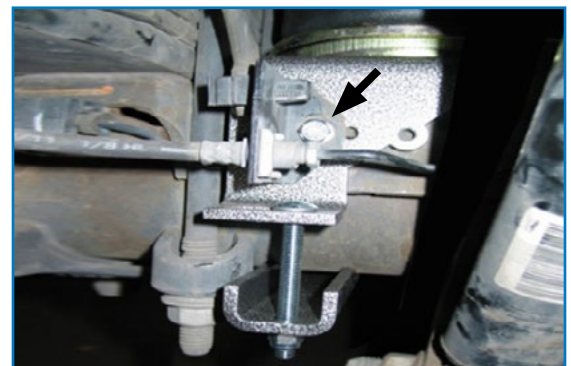

11A

13 INSTALL AIR LINE

PLEASE NOTE: This kit contains push-to-connect fittings; using scissors or wire cutters to cut the nylon airline will distort the line and cause the connection to leak. THE AIRLINE MUST BE CUT OFF SQUARELY WITH THE NYLON HOSE CUTTER PROVIDED IN THIS KIT OR A SHARP UTILITY KNIFE

Provided in air spring kit are two fill valves. The most common place to install is in place of license plate fasteners. Alternatively, two 5/16" holes can be drilled in a convenient location.

Cut air line assembly into two equal lengths with hose cutter.

Install one air line, route the nylon air line to an air spring fitting and cut the hose. Moisten the end of the air line prior to inserting it into the fitting and push it in until it stops. Repeat with the other fill valve.

Secure airlines using the tie-straps, away from moving items and heat sources.

Place a 5/16" nut on the air valve. Leave enough of the inflation valve in front of the nut to extend through the hole, install a flat washer, and 5/16" nut and cap (reference Figure 13 on the following page for assembly). There should be enough valve exposed after installation—approximately 1/2"—to easily apply a pressure gauge or an air chuck.

If an in-cab inflation kit is being installed, follow the instructions provided with that kit now.

14 CHECK SYSTEM FOR LEAKS

Inflate both air springs to 90 psi and then use a mixture of dish soap and water on all air line connections to detect any air leaks. Large, expanding bubbles indicate a leak (as shown in Figure 14 on the following page).

Repair as necessary and retest.

Inflate air springs to a predetermined value and on following day recheck pressure.

If one or both of air springs have lost pressure, an air leak is present.

Leak must be repaired, and then retested until no leaks exist.



11B



11C



12

AFTER COMPLETING THE INSTALLATION

PLEASE REMEMBER:

Install wheels and torque fasteners to manufacturer's specifications.

Re-torque all fasteners after first 500 miles of driving.

For safe and proper operation, never operate the vehicle under minimum of 10 psi or over maximum of 100 psi in air springs. Staying within pressure limit will ensure maximum air spring life. Failure in doing so may result in a void warranty (see **Note** below).

NOTE: Do not exceed maximum vehicle payload. Failure to do so may result in failure of the air suspension kit and/or damage to your vehicle.

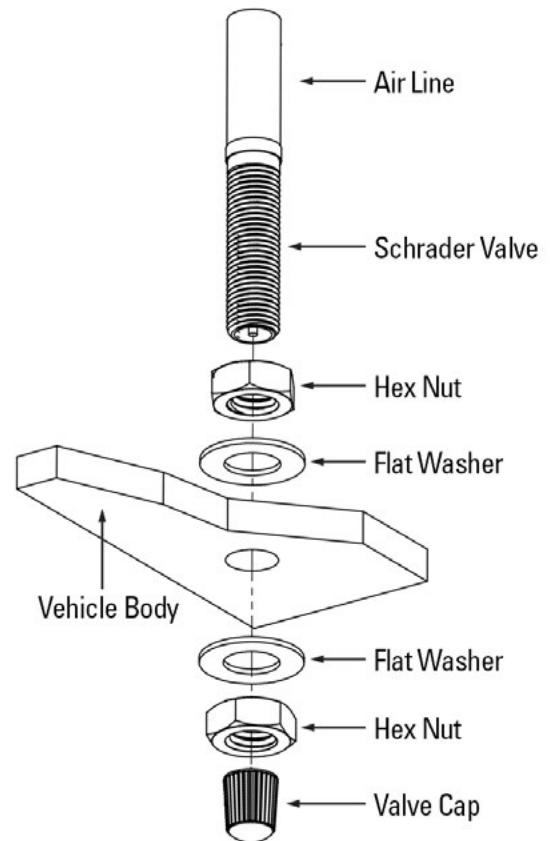

13



14

Thank you again, and congratulations on the installation of the air suspension kit.

OPTIONAL ACCESSORIES

Optional dual needle air gauges are available to monitor pressure in each spring from vehicle cab, as well as a full line of air compressors, air tanks, and solenoids built to work with and control your air spring system.

OPERATING YOUR VEHICLE WITH AIR SUSPENSION

Air springs have minimum and maximum pressure requirements. Never operate your vehicle with less than 10 psi in air spring and never inflate air springs over 100 psi. Damage to air springs will result.

Check air pressure in air springs daily for first couple of days to ensure a leak has not developed. Air springs are designed to maintain the vehicles stock ride height with a load. Do not use the air springs as a means to lift vehicle with no load. This will result in a harsh ride.

SERVICING YOUR VEHICLE WITH AIR SUSPENSION

When lifting the vehicle with a floor jack or hoist on the frame, never allow the air spring to limit the travel of the axle. Try to always jack the vehicle on the axle. Suspending the axle with the air spring limiting the axle travel will damage the air spring and void the air spring warranty.

WARRANTY

To be eligible for warranty, the owner must submit their warranty card or register online within 30 days of the purchase date.

NOTE: The owner's warranty will be void if air springs are run with less than the minimum of 10 psi.

.....