

Installation Manual

VERSION
FRANÇAISE



10005-X KIT

GMC/Chevrolet 2500 & 3500 2WD/4WD*

Eliminate your vehicle's sag, sway and bottoming out while providing added support for an overall smooth and safe ride with this extreme duty air suspension kit. Rated for up to 7500 lbs of load-leveling capacity⁺, this kit is ideally suited for those towing/hauling big loads on a regular basis.

* See application guide for proper fitment.

+ Applications vary. Never exceed manufacturer's recommended Gross Vehicle Weight Rating



WARNING: This product can expose you to the chemical Hexavalent Chromate, which is known to the State of California to cause cancer and birth defects or other reproductive harm. *For more information go to www.P65Warnings.ca.gov*

Thank you and congratulations on the purchase of an air suspension kit. Please read the entire manual prior to starting the installation to ensure you can complete it once started.

IMPORTANT

This air suspension kit will not increase the GVWR (*Gross Vehicle Weight Rating*), as the GVWR is determined by the vehicle manufacturer. **Do not exceed the maximum capacity listed by the vehicle manufacturer.**

PLEASE NOTE: The air bag must have clearance between itself and the surrounding components to prevent any contact when bag is inflated or compressed. Trimming off excess bolt length is also required to ensure no contact with the bag or other suspension components can be made once installed.

Safety Warnings!

- ❗ Serious personal injury or death may result from an air spring failure or accident due to improper installation or air spring pressure operation or maintenance. Please read and abide the instructions, safety recommendations and maintenance suggestions throughout this manual.
 - ❗ Inflating an unsecured air spring is dangerous. If it bursts, it could be hurled into the air with explosive force resulting in serious personal injury or death. Never inflate an air spring unless it is secured to the vehicle.
 - ❗ Removing and replacing air springs can be dangerous. This is only a job for a qualified service professional. Never perform air spring service procedures without proper training, tools, and equipment.
-

KIT CONTENTS

Reference the kit explosion diagram on the following page for part assembly.

KIT CONTENTS			REQUIRED TOOLS		
	QTY	PART #			
A Extreme Duty Air Spring	2	HP10438	• Hoist or Floor Jack		
B Roll Plate	4	HP10069	• Safety Stands		
C Upper Bracket	2	HP1666	• Safety Glasses		
D Lower Bracket	2	HP1667	• Torque Wrench		
E Brake Line Relocation Bracket	1	HP1668	• Standard Combination Wrenches		
F Axle Strap	2	HP0009	• 7/32" Hex Allen Wrench		
G 5/8" Adel Clamp	1	HP1006	• 1-1/8" Wrench or Deep Socket		
H Bolt, 3/8" – 24 X 7/8" Hex Head	4	HP1002	• Ratchet		
I Bolt, 3/8" – 24 X 7/8" Countersunk	4	HP1008	• Metric & Standard Sockets		
J Bolt, 3/8" – 16 X 5" Carriage	4	HP1022	• Hose Cutter (included) or Sharp Utility Knife		
K Bolt, 3/8" – 16 X 1.5" Hex Head	4	C18018	• Pipe Thread Sealant		
L Bolt, 5/16" – 18 X 1" Flange	1	C11819	• Spray Bottle with Dish Soap/Water		
M Stud, 5/16" – 18 X 7/8" Clinch	1	HP1007	• Air Compressor/Compressed Air Source (to test/fill air springs)		
N Washer, 3/8" Flat	12	C653			
O Washer, 5/16" Flat	2	C11944			
P Washer, 3/8" Split Lock	4	C18007			
Q Nut, 3/8" Serrated Flange	4	HP1338			
R Nut, 3/8" Nylon Lock	4	HP1000			
S Nut, 5/16" Nylon Lock	2	C11943			
T Heat Shield	1	HP0012			
U Worm Gear Ring Clamp	2	HP1001			
V Fitting, 90° Brass	2	HP1245			
W Airline Hose Assembly (<i>not shown</i>)	1	HP1344			
X Tie Strap (<i>not shown</i>)	6	C11618			

Please make sure all the items shown in this explosion diagram are provided in your kit before starting the installation.

DRIVER SIDE ASSEMBLY SHOWN:

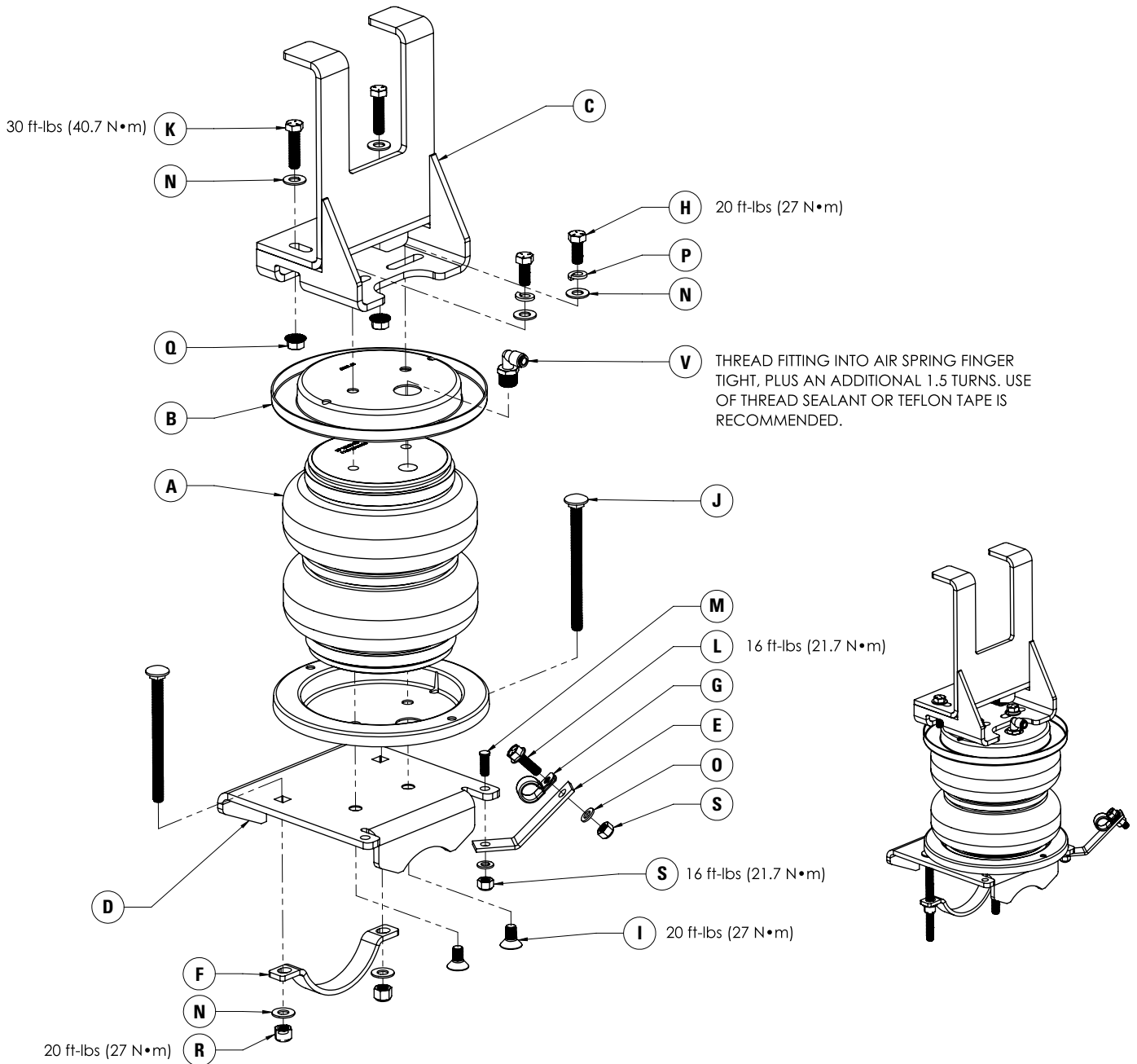

BEFORE STARTING THE INSTALLATION:

1. Ensure the application information is correct for the make, model and year of the vehicle you are installing the kit on.
2. Some vehicles are equipped with a rear wheel brake proportioning valve. Check with the manufacturer before installing the air spring kit, as it may affect braking performance.
3. It is recommended to use a good quality anti-seize on all fasteners. This will reduce the chance of corrosion on the fasteners and will help facilitate removal, if required at a later date.

PLEASE NOTE:

This kit contains push-to-connect fittings; using scissors or wire cutters to cut the nylon airline will distort the line and cause the connection to leak. THE AIRLINE MUST BE CUT OFF SQUARELY WITH THE NYLON HOSE CUTTER PROVIDED IN THIS KIT OR A SHARP UTILITY KNIFE.

1 MEASURE STOCK RIDE HEIGHT

Park the vehicle on a level surface. Remove any unnecessary weight from the vehicle to attain a Normal Ride Height. This is important for correct initial air spring set-up and adjustment.

Using a measuring tape, measure the distance between the center of the wheel hub and the bottom of the fender well (as shown in Figure 1) this will give you your ride height.

Note the ride height for all four corners.

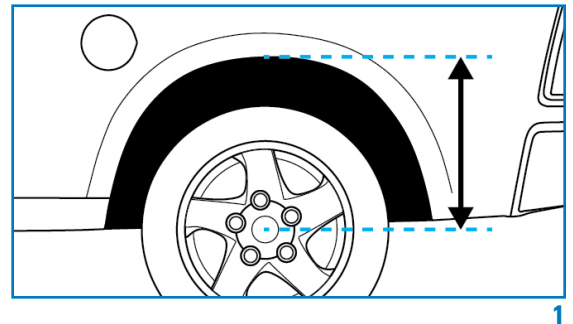

1

2 REMOVE REAR WHEELS

Place wheel chocks in front of and behind both front wheels.

Raise the rear of the truck high enough to remove both wheels and attain a comfortable working height.

Place two jack stands under rear axle (shown in Figure 2).

Lower the vehicle until the axle is supported by the jack stands.

Remove rear wheels.



2

3 REMOVE JOUNCE BUMPER

Remove the two bolts and flange nuts securing the jounce bumper to the frame rail on both sides of the vehicle.

Discard the hardware as it will not be reused in this installation.

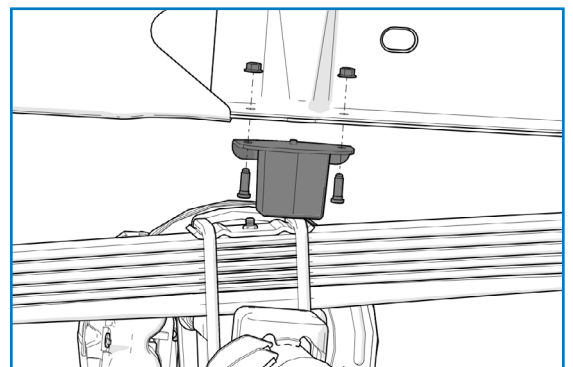

3

4 INSTALL UPPER BRACKETS

Insert two 3/8" – 16 X 1.5" hex bolts with two 3/8" flat washers through the frame holes previously occupied by the jounce bumper hardware (shown in Figure 4A).

Position the upper bracket on the frame as shown in Figure 4B.

On the driver side, ensure the hard brake line passes between the two vertical flanges of the bracket.

Note: *On some models, a harness mount may need to be removed from the upper frame rail hole (circled in red) in order for the upper bracket to sit correctly.*

Install two 3/8" serrated flange nuts on the hex bolts and torque bolts to 20 ft-lbs (27 N•m).

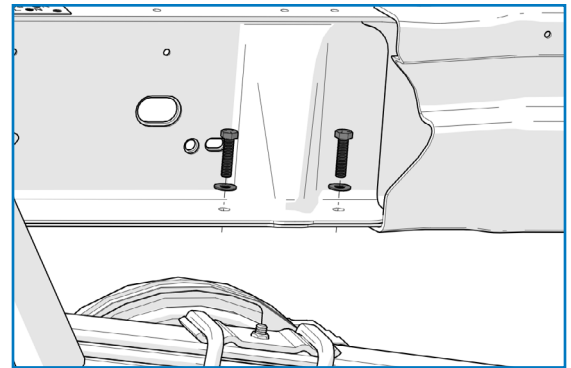

4A

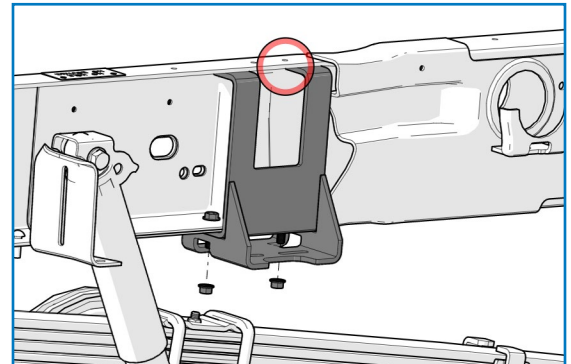

4B

5 ASSEMBLE AIR SPRINGS

Assemble the air springs as shown in Figure 5.

First insert two 3/8" – 16 X 5" carriage bolts through the square holes in the lower bracket.

On one spring assembly, install the brake line relocation bracket and secure with a 5/16" – 18 X 7/8" clinch stud, 5/16" flat washer and 5/16" nylon lock nut.

Do not fully tighten hardware yet.

Place a roll plate on the bottom surface of the air spring followed by a bracket with carriage bolts.

Align the holes in the air spring, roll plate and bracket and secure with two 3/8" – 24 x 7/8" countersunk bolts.

Torque bolts to 20 ft-lbs (27 N•m).

Turn the assembly over and place a roll plate on the top surface of the air spring.

Install the air fitting into the air spring finger tight plus an additional 1.5 turns. The use of thread sealant or Teflon tape is recommended.

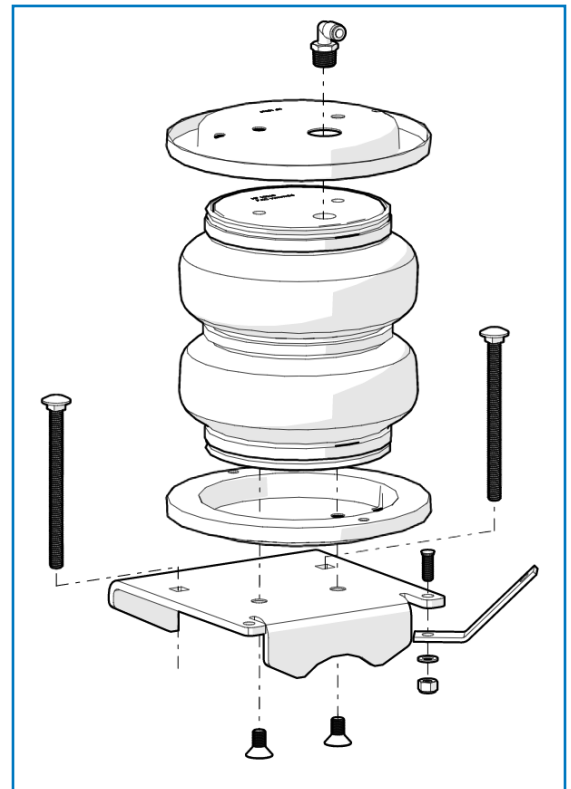

5

6 INSTALL AIR SPRING IN VEHICLE

Note: It may be necessary to raise the frame of the truck a few inches to allow more clearance to install the air spring assemblies

Set the air spring assembly in position as shown in Figure 6A. Ensure the spring assembly with the brake line relocation bracket is installed on the driver side of the vehicle.

Secure the air spring to the upper bracket using two 3/8" – 24 X 7/8" hex head bolts two 3/8" lock washers and two 3/8" flat washers.

Correctly align the air spring vertically (as per Figure 6B) and torque bolts to 20 ft-lbs (27 N•m).

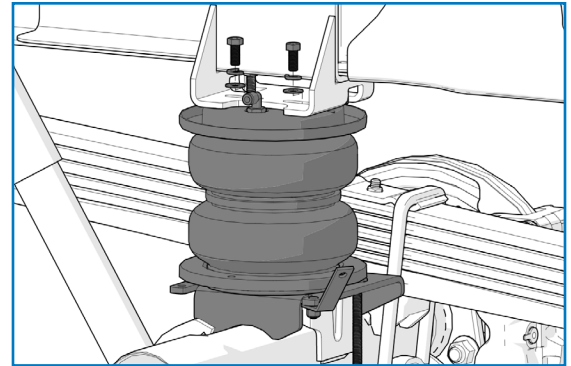

6A

7 ATTACH AXLE STRAP

Attach the axle strap to the earlier installed carriage bolts as shown in Figure 7 using two 3/8" flat washers and two 3/8" nylon lock nuts.

Ensure the air spring remains vertical and torque lock nuts to 20 ft-lbs (27 N•m).

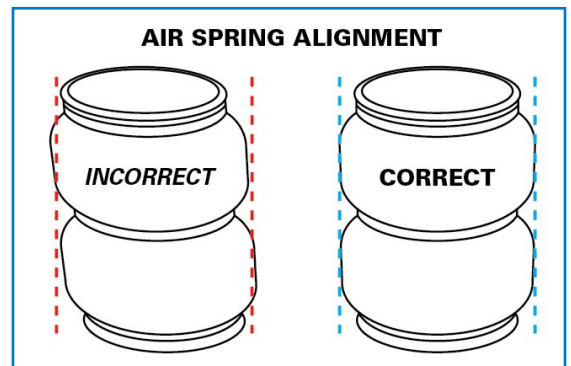

6B

8 RELOCATE EMERGENCY BRAKE LINE

On the driver side assembly, attach the adel clamp around the emergency brake line next to the air spring.

Secure the adel clamp to the relocation bracket (see Figure 8 for assembly reference) with a 5/16" – 18 x 1" flange bolt, 5/16" flat washer and 5/16" nylon lock nut.

Torque bolt to 16 ft-lbs (21.7 N•m).

Note: It may be necessary to bend the brake line relocation bracket upwards towards the air spring if it is too close to the fuel tank.

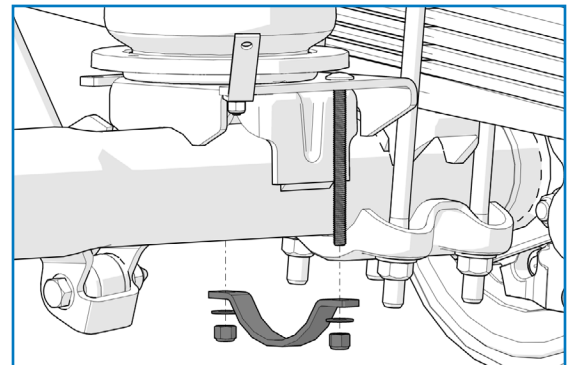

7

9 INSTALL HEAT SHIELD

Bend tabs on the heat shield so the required 1/2" of dead space exists between the heat shield and exhaust when attached.

Attach the heat shield to the exhaust pipe on passenger side using two ring clamps (shown in Figure 9 on the following page). Each hose clamp holds a tab against exhaust pipe.

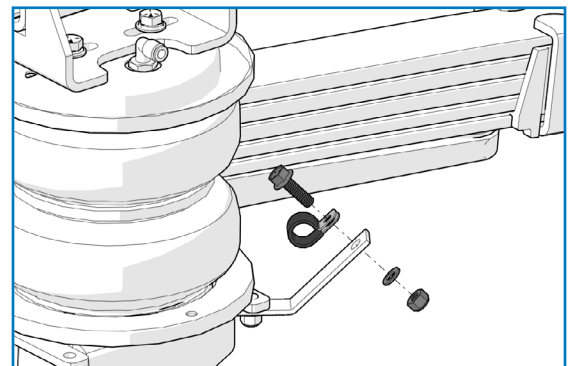

8

10 INSTALL AIR LINE

PLEASE NOTE: This kit contains push-to-connect fittings; using scissors or wire cutters to cut the nylon airline will distort the line and cause the connection to leak. THE AIRLINE MUST BE CUT OFF SQUARELY WITH THE NYLON HOSE CUTTER PROVIDED IN THIS KIT OR A SHARP UTILITY KNIFE

Provided in air spring kit are two fill valves. The most common place to install is in place of license plate fasteners. Alternatively, two 5/16" holes can be drilled in a convenient location.

Cut air line assembly into two equal lengths with hose cutter.

Install one air line, route the nylon air line to an air spring fitting and cut the hose. Moisten the end of the air line prior to inserting it into the fitting and push it in until it stops. Repeat with the other fill valve.

Secure airlines using the tie-straps, away from moving items and heat sources.

Place a 5/16" nut on the air valve. Leave enough of the inflation valve in front of the nut to extend through the hole, install a flat washer, and 5/16" nut and cap (reference Figure 10 for assembly). There should be enough valve exposed after installation—approximately 1/2"—to easily apply a pressure gauge or an air chuck.

If an in-cab inflation kit is being installed, follow the instructions provided with that kit now.

11 CHECK SYSTEM FOR LEAKS

Inflate both air springs to 90 psi and then use a mixture of dish soap and water on all air line connections to detect any air leaks. Large, expanding bubbles indicate a leak (as shown in Figure 11).

Repair as necessary and retest.

Inflate air springs to a predetermined value and on following day recheck pressure.

If one or both of air springs have lost pressure, an air leak is present.

Leak must be repaired, and then retested until no leaks exist.



9

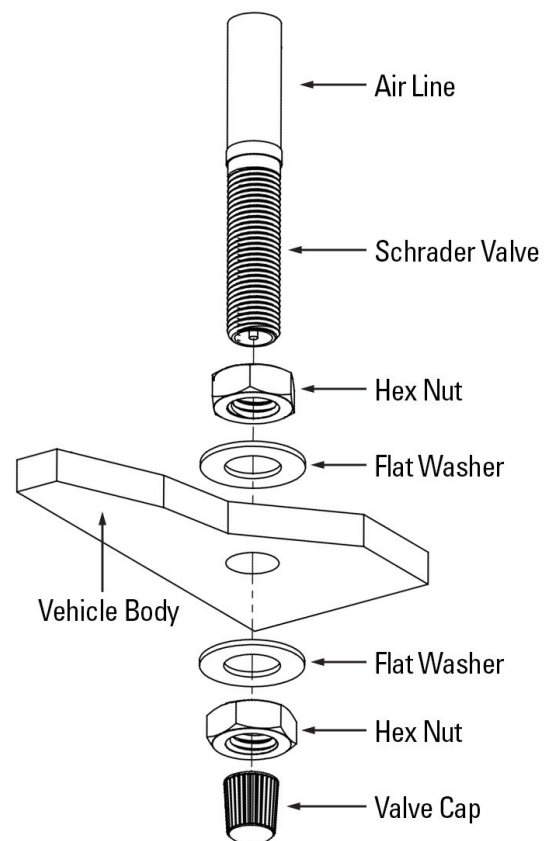

10

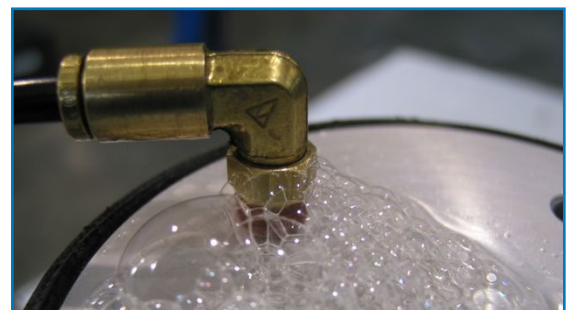

11

AFTER COMPLETING THE INSTALLATION

PLEASE REMEMBER:

Install wheels and torque fasteners to manufacturer's specifications.

Re-torque all fasteners after first 500 miles of driving.

For safe and proper operation, never operate the vehicle under minimum of 10 psi or over maximum of 100 psi in air springs. Staying within pressure limit will ensure maximum air spring life. Failure in doing so may result in a void warranty (see **Note** below).

NOTE: Do not exceed maximum vehicle payload. Failure to do so may result in failure of the air suspension kit and/or damage to your vehicle.

.....

Thank you again, and congratulations on the installation of the air suspension kit.

OPTIONAL ACCESSORIES

Optional dual needle air gauges are available to monitor pressure in each spring from vehicle cab, as well as a full line of air compressors, air tanks, and solenoids built to work with and control your air spring system.

OPERATING YOUR VEHICLE WITH AIR SUSPENSION

Air springs have minimum and maximum pressure requirements. Never operate your vehicle with less than 10 psi in air spring and never inflate air springs over 100 psi. Damage to air springs will result.

Check air pressure in air springs daily for first couple of days to ensure a leak has not developed. Air springs are designed to maintain the vehicles stock ride height with a load. Do not use the air springs as a means to lift vehicle with no load. This will result in a harsh ride.

SERVICING YOUR VEHICLE WITH AIR SUSPENSION

When lifting the vehicle with a floor jack or hoist on the frame, never allow the air spring to limit the travel of the axle. Try to always jack the vehicle on the axle. Suspending the axle with the air spring limiting the axle travel will damage the air spring and void the air spring warranty.

WARRANTY

To be eligible for warranty, the owner must submit their warranty card or register online within 30 days of the purchase date.

NOTE: The owner's warranty will be void if air springs are run with less than the minimum of 10 psi.

.....