

Installation Manual



10126 / 10128 / 10158[†] KIT

Toyota Tundra 2WD/4WD*

Use the most advanced air springs on the market to eliminate your vehicle's sag, sway and bottoming out. This heavy duty air suspension kit levels your truck's stance while providing added support for an overall smooth and safe ride.

* See application guide for proper fitment.

† Fits vehicles with Jounce Bumper 1" below frame

L6010_REV16_07.21.2022



WARNING: This product can expose you to the chemical Hexavalent Chromate, which is known to the State of California to cause cancer and birth defects or other reproductive harm. *For more information go to www.P65Warnings.ca.gov*

Thank you and congratulations on the purchase of an air suspension kit. Please read the entire manual prior to starting the installation to ensure you can complete it once started.

IMPORTANT

This air suspension kit will not increase the GVWR (*Gross Vehicle Weight Rating*), as the GVWR is determined by the vehicle manufacturer. **Do not exceed the maximum capacity listed by the vehicle manufacturer.**

PLEASE NOTE: *The air bag must have clearance between itself and the surrounding components to prevent any contact when bag is inflated or compressed. Trimming off excess bolt length is also required to ensure no contact with the bag or other suspension components can be made once installed.*

Safety Warnings!

- ❗ Serious personal injury or death may result from an air spring failure or accident due to improper installation or air spring pressure operation or maintenance. Please read and abide the instructions, safety recommendations and maintenance suggestions throughout this manual.
 - ❗ Inflating an unsecured air spring is dangerous. If it bursts, it could be hurled into the air with explosive force resulting in serious personal injury or death. Never inflate an air spring unless it is secured to the vehicle.
 - ❗ Removing and replacing air springs can be dangerous. This is only a job for a qualified service professional. Never perform air spring service procedures without proper training, tools, and equipment.
-

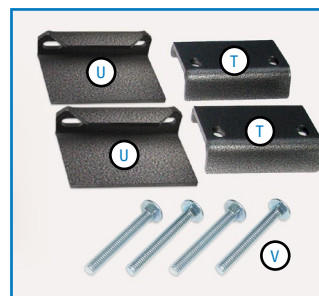
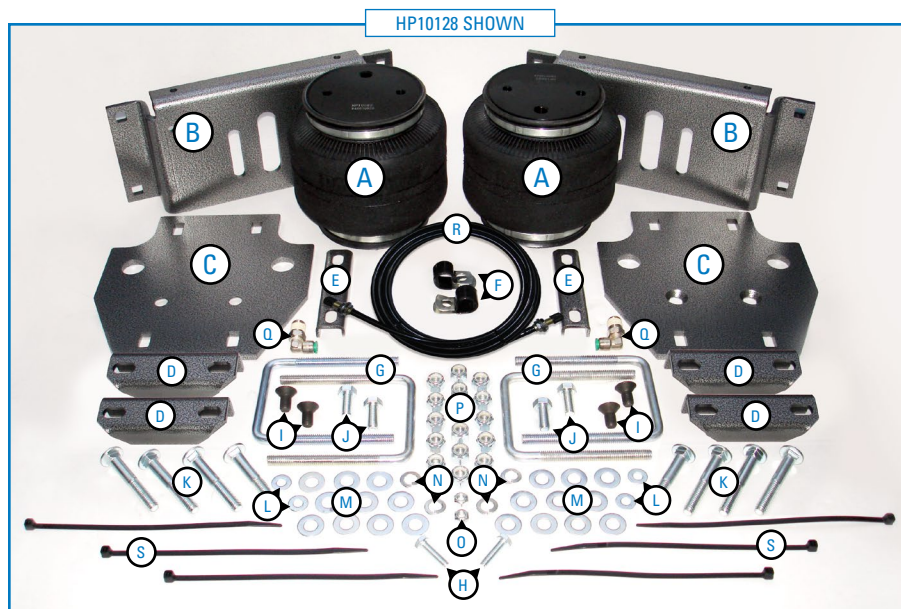

KIT CONTENTS NOTES:

- ▶ 10128 Kit is shown in the photo.
- ▶ 10126 Kits: 2 Clamps (D) are removed & 2 Clamps (T) are added.
- ▶ 10158 Kits: 2 Clamps (D) are removed & 2 Clamps (U) are added.

KIT CONTENTS

Please make sure all the items shown in the kit layout are provided in your kit before starting the installation. Reference the kit explosion diagram on the following page for part assembly.

| KIT CONTENTS | | QTY | PART # |
|--------------|--|-------|---------|
| A | Air Spring | 2 | HP10083 |
| B | Lower Bracket | 2 | HP0104 |
| C | Upper Bracket | 2 | HP0110 |
| D | Clamp [10128 kits] / [10126 & 10158 kits] | 4 / 2 | HP0112 |
| E | Bracket Spacer | 2 | HP0113 |
| F | 5/8" Loop Strap, vinyl coated | 2 | HP1006 |
| G | U-Bolt | 4 | HP1018 |
| H | 1/4"-28 x 1" Bolt | 2 | C10448 |
| I | 3/8"-24 x 3/4" Countersunk Capscrew | 4 | HP1008 |
| J | 3/8"-24 x 7/8" Bolt | 4 | HP1002 |
| K | 3/8"-16 x 2 1/2" Carriage Bolt [10126 & 10128 kits] / [10158 kits] | 8 / 4 | HP1005 |
| L | 1/4" Flat Washer | 4 | P02190 |
| M | 3/8" Flat Washer | 20 | C653 |
| N | 3/8" Lock Washer | 4 | C18007 |
| O | 1/4" Nut Stover | 2 | C11844 |
| P | 3/8"-16 Nylock Nut | 16 | HP1000 |
| Q | 90° Fitting | 2 | HP1100 |
| R | Air Line/Valve Assembly | 1 | HP1344 |
| S | Tie Straps | 6 | C11618 |
| T | Clamp [10126 kit only] | 2 | HP0111 |
| U | Clamp [10158 kits only] | 2 | HP0124 |
| V | 3/8"-16 x 3" Carriage Bolts [10158 kits only] | 4 | HP1003 |

REQUIRED TOOLS

- Hoist or Floor Jack
- Safety Stands
- Safety Glasses
- Torque Wrench
- Standard Combination Wrenches
- 7/32" Hex Allen Wrench
- 1-1/8" Wrench or Deep Socket
- Ratchet
- Metric & Standard Sockets
- Hose Cutter (included) or Sharp Utility Knife
- Pipe Thread Sealant
- Sawzall or hacksaw
- Spray Bottle with Dish Soap/Water
- Air Compressor/Compressed Air Source (to test/fill air springs)

Please make sure all the items shown in this explosion diagram are provided in your kit before starting the installation.

DRIVER SIDE ASSEMBLY SHOWN:

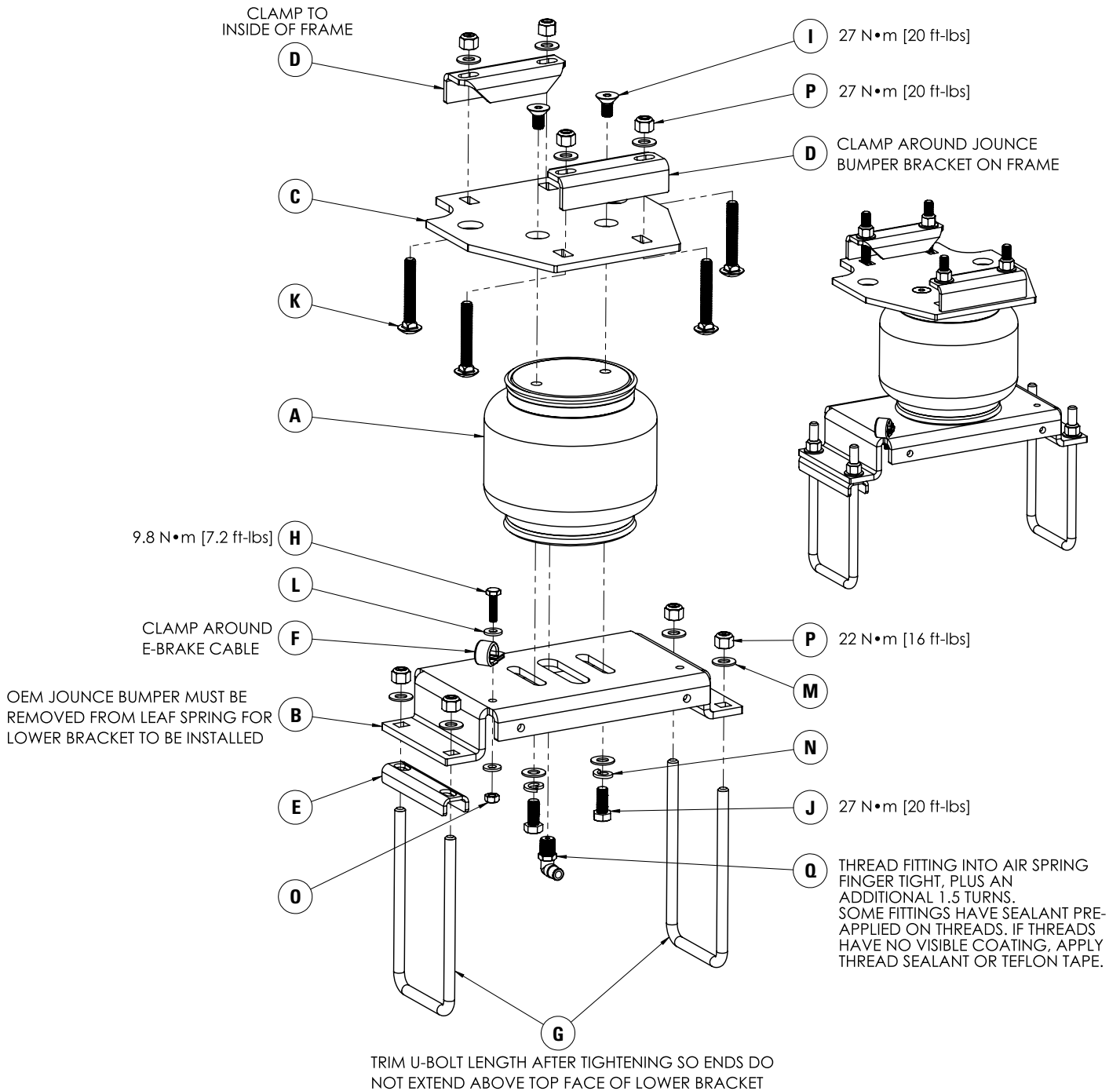

BEFORE STARTING THE INSTALLATION:

1. Ensure the application information is correct for the make, model and year of the vehicle you are installing the kit on.
2. Some vehicles are equipped with a rear wheel brake proportioning valve. Check with the manufacturer before installing the air spring kit, as it may affect braking performance.
3. It is recommended to use a good quality anti-seize on all fasteners. This will reduce the chance of corrosion on the fasteners and will help facilitate removal, if required at a later date.

PLEASE NOTE:

This kit contains push-to-connect fittings; using scissors or wire cutters to cut the nylon airline will distort the line and cause the connection to leak. THE AIRLINE MUST BE CUT OFF SQUARELY WITH THE NYLON HOSE CUTTER PROVIDED IN THIS KIT OR A SHARP UTILITY KNIFE.

1 MEASURE STOCK RIDE HEIGHT

Park the vehicle on a level surface. Remove any unnecessary weight from the vehicle to attain a Normal Ride Height. This is important for correct initial air spring set-up and adjustment.

Using a measuring tape, measure the distance between the center of the wheel hub and the bottom of the fender well (as shown in Figure 1) this will give you your ride height.

Note the ride height for all four corners.

Check the clearance between the outside of the frame and the inside of the tire, a minimum of 5" is required for air spring clearance.

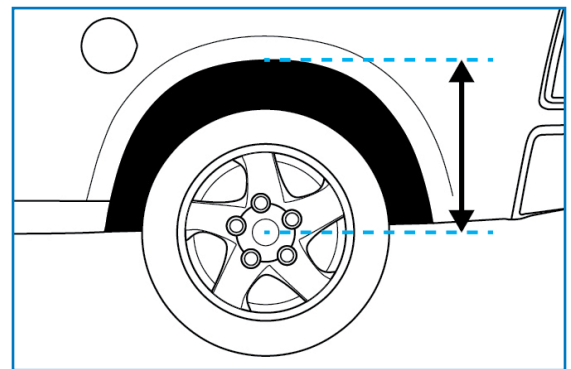

1

2 REMOVE REAR WHEELS

Place wheel chocks in front of and behind both front wheels.

Raise the rear of the truck high enough to remove both wheels and attain a comfortable working height.

Place two jack stands under rear axle (shown in Figure 2).

Lower the vehicle until the axle is supported by the jack stands.

Remove rear wheels.



2

3 REMOVE THE JOUNCE BUMPER

Using a sawzall or hacksaw, remove the jounce bumper by cutting the rubber portion off (as shown in the Figures 3A & 3B).

PLEASE NOTE: It is permissible to remove the jounce bumper by loosening the axle U-bolts and slipping the jounce bumper assembly out from underneath the U-bolts. **HOWEVER**, take precaution if you follow this method of removal, as the axle can shift from its factory mounting point to the leaf springs.

4 DETACH E-BRAKE

Remove the factory emergency brake cable support bracket in order to obtain clearance for the lower bracket.

A supplied support for the emergency brake cable will be installed in Step 14.

5 INSTALL AIR FITTING

Locate the 90° fittings and air springs provided, apply thread sealant to the threads, install the fitting into the port of the air spring (as shown with an arrow in Figure 5).

6 LOWER BRACKET ASSEMBLY

Place the air spring in front of you with the air fitting set on the opposite side of you pointing upwards (as seen in Figure 6).

Place the lower bracket over the fitting with the bent flanges facing upwards and towards you (see Figure 6 as reference).

Loosely install the 2 - 3/8" X 24 x 7/8" capscrews with lock and flat washers provided through the lower bracket into the two threaded holes of the air spring.

Do not tighten the two capscrews as adjustment will be required later is the installation.

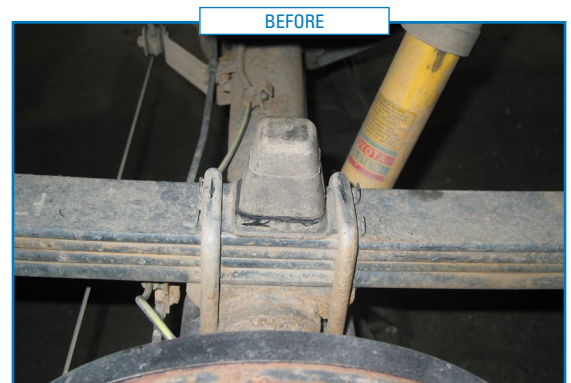

3A



3B



5

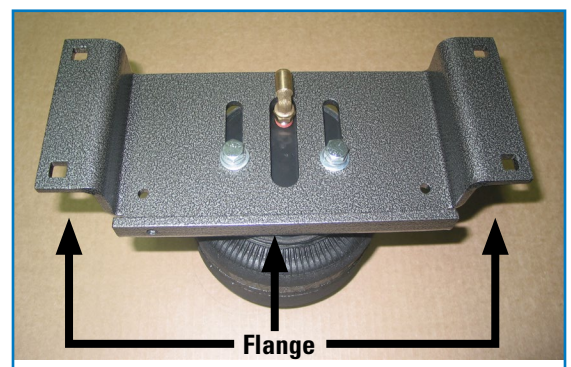

6

7 UPPER BRACKET ASSEMBLY

Turn the air spring & lower bracket assembly over. The bent flange of the lower bracket must be facing towards you.

Place the upper mounting bracket on top of the air spring, with countersunk holes facing up and the angled sides towards you (as seen in Figure 7).

Using the 2-3/8"-24 x 7/8" countersunk capscrews provided, torque to 20 ft-lbs, 27N.m.

Attach the upper bracket to the air spring assembly and tighten the countersink capscrews securely.

Repeat Steps 5-7 for the other air spring.

8 INSTALL AIR SPRING ASSEMBLY

Ensure the lower air spring bracket is parallel to the frame flange directly above the upper air spring bracket.

10126 KITS ONLY Lower bracket spacers are provided to shim the lower bracket if necessary, the spacers are installed with the legs against the leaf springs.

9 INSTALL U-BOLTS

Loosely install the U-bolts around the leaf spring and up through the lower air spring mounting bracket holes and spacers (if used).

Install the flat washers and 3/8" nyloc nuts provided on the U-bolts.

10 DETERMINE THE CORRECT UPPER CLAMPS

PLEASE NOTE: The difference between kits is the upper bracket clamp(s) - and longer carriage bolts for the 10158 kits. Use the Assembly Diagrams & Part Callouts below to determine the correct inner & outer brackets to use for your application.

10126 KITS (Figure 10A)

- ▶ Outer Clamps: HP0111
- ▶ Inner Clamps: HP0112

10128 KITS (Figure 10B)

- ▶ Outer Clamps: HP0112
- ▶ Inner Clamps: HP0112

10158 KITS (Figure 10C on following page)

- ▶ Outer Clamps: HP0112
- ▶ Inner Clamps: HP0124
- ▶ + 3" Carriage Bolts: HP1003

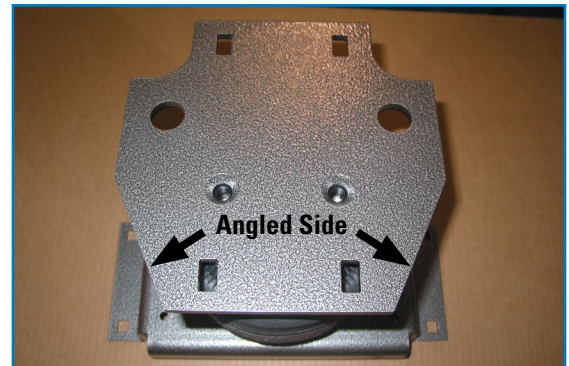

7



8

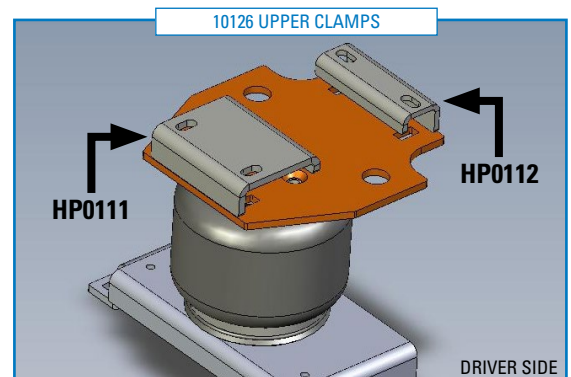

10A

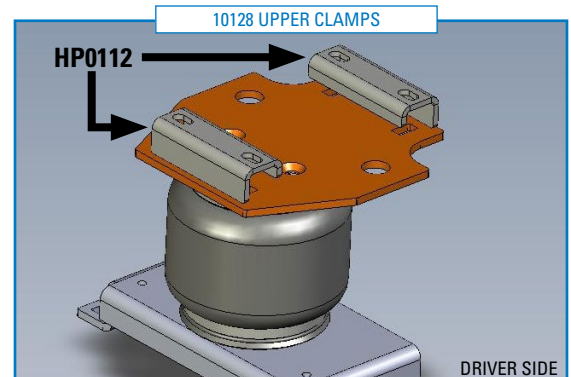

10B

11 INSTALL UPPER CLAMPS

Use the information from the previous step to determine the correct upper clamps for your vehicles application

Loosely install the upper outer clamp bracket onto the upper air spring bracket installing the 2-3/8" x 2 1/2" NC carriage bolts from the bottom (see Figure 11A), using flat washers and nyloc nuts provided.

The shorter leg of the clamp must be installed towards the frame.

Repeat for the upper inner clamp (Figure 11B)

12 UPPER AIR SPRING BRACKET CLAMP ALIGNMENT

The upper air spring bracket clamps must be positioned with one leg on the frame and the other leg squarely on top of the upper bracket (see Figure 12 for reference).

Once this alignment is complete, torque the 2 inner and 2 outer clamp carriage bolts to 20 ft-lbs, 27 N•m.

13 AIR SPRING ASSEMBLY ALIGNMENT

Position the lower air spring mounting bracket on the leaf spring.

Align the lower end of the air spring to the top by moving the lower air spring bracket to the front or rear of the leaf spring to achieve correct air spring alignment (see Figure 13A for reference).

Once the alignment is correct, torque the 4 U-bolt nuts evenly to 16 ft-lbs (see Figure 13B).

Then align the lower end of the air spring to the top by sliding the lower end in or out on the elongated holes in the lower bracket.

Once alignment is correct, torque the lower air spring to bracket capscrews to 20 ft-lbs, 27 N•m (see Figure 13C).

Cut off the threaded portion of the U-bolts above the nyloc nut (see Figure 13D).

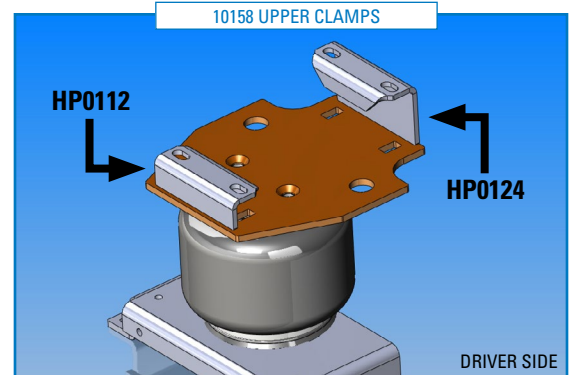

10C

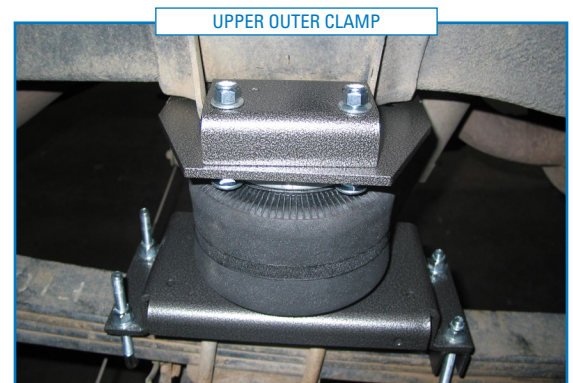

11A

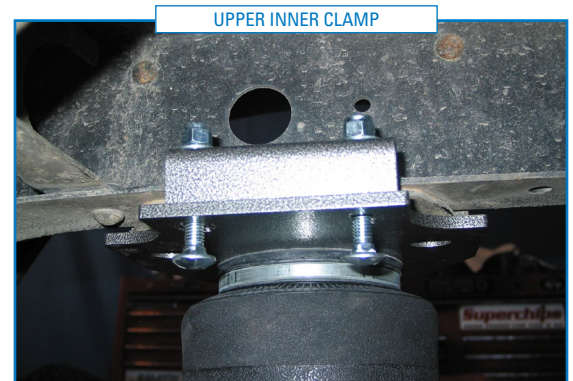

11B

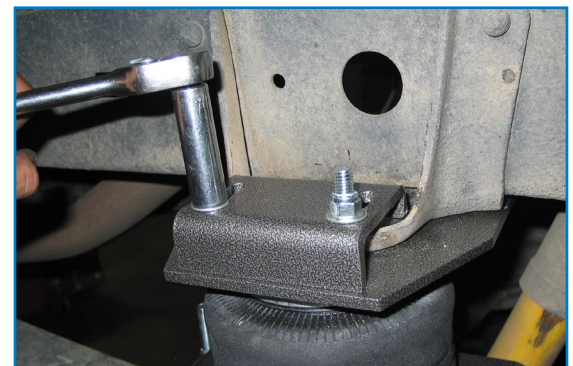

12

14 REATTACH E-BRAKE

Install the Adel clamp provided around the emergency brake cable, using the ¼-28 x 1 bolts flat washer and nyloc nuts provided.

Fasten the Adel clamp to the forward hole in the top of the lower bracket (as shown in Figure 14 on the following page).

Repeat Steps 4-14 for the other air spring.

15 INSTALL AIR LINE

PLEASE NOTE: This kit contains push-to-connect fittings; using scissors or wire cutters to cut the nylon airline will distort the line and cause the connection to leak. THE AIRLINE MUST BE CUT OFF SQUARELY WITH THE NYLON HOSE CUTTER PROVIDED IN THIS KIT OR A SHARP UTILITY KNIFE

Provided in air spring kit are two fill valves. The most common place to install is in place of license plate fasteners. Alternatively, two 5/16" holes can be drilled in a convenient location.

Cut air line assembly into two equal lengths with hose cutter.

Install one air line, route the nylon air line to an air spring fitting and cut the hose. Moisten the end of the air line prior to inserting it into the fitting and push it in until it stops. Repeat with the other fill valve.

Secure airlines using the tie-straps, away from moving items and heat sources.

Place a 5/16" nut on the air valve. Leave enough of the inflation valve in front of the nut to extend through the hole, install a flat washer, and 5/16" nut and cap (reference Figure 15 on following page for assembly).

There should be enough valve exposed after installation — approximately ½" — to easily apply a pressure gauge or an air chuck.

If an in-cab inflation kit is being installed, follow the instructions provided with that kit now.

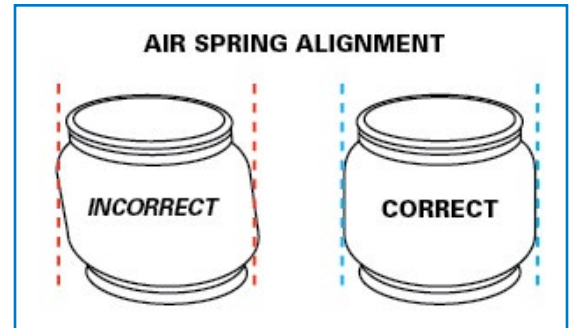

13A

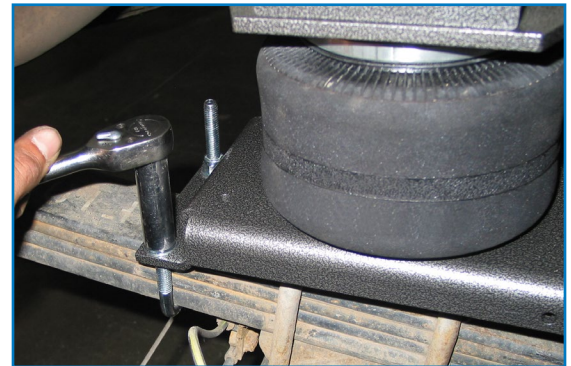

13B

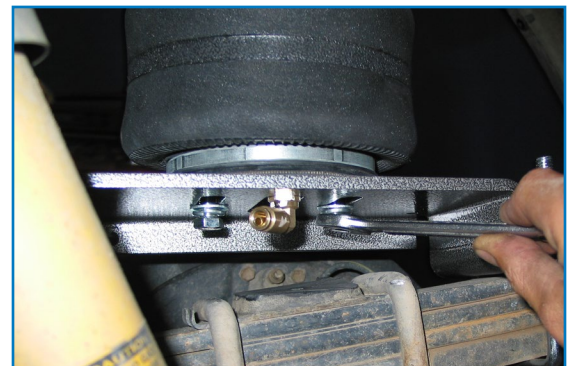

13C



13D

16 CHECK SYSTEM FOR LEAKS

Inflate both air springs to 90 psi and then use a mixture of dish soap and water on all air line connections to detect any air leaks. Large, expanding bubbles indicate a leak (as seen in Figure 16).

Repair as necessary and retest.

Inflate air springs to a predetermined value and on following day recheck pressure. If one or both of air springs have lost pressure, an air leak is present. Leak must be repaired, and then retested until no leaks exist.



14

17 AFTER COMPLETING THE INSTALLATION

PLEASE REMEMBER:

Install wheels and torque fasteners to manufacturer's specifications.

Re-torque all fasteners after first 500 miles of driving.

For safe and proper operation, never operate the vehicle under minimum of 10 psi or over maximum of 100 psi in air springs. Staying within pressure limit will ensure maximum air spring life. Failure in doing so may result in a void warranty (see **Note** below).

NOTE: Do not exceed maximum vehicle payload. Failure to do so may result in failure of the air suspension kit and/or damage to your vehicle.

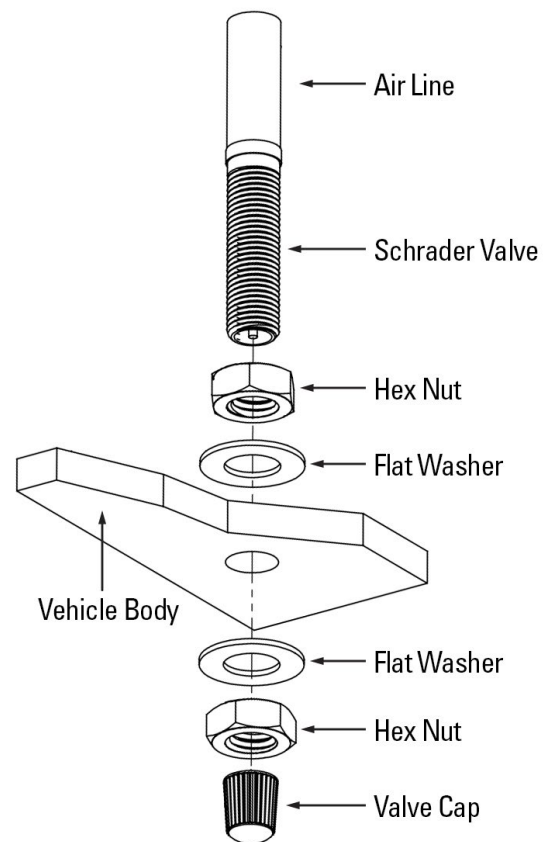

15



16

Thank you again, and congratulations on the installation of the air suspension kit.

OPTIONAL ACCESSORIES

Optional dual needle air gauges are available to monitor pressure in each spring from vehicle cab, as well as a full line of air compressors, air tanks, and solenoids built to work with and control your air spring system.

OPERATING YOUR VEHICLE WITH AIR SUSPENSION

Air springs have minimum and maximum pressure requirements. Never operate your vehicle with less than 10 psi in air spring and never inflate air springs over 100 psi. Damage to air springs will result.

Check air pressure in air springs daily for first couple of days to ensure a leak has not developed. Air springs are designed to maintain the vehicles stock ride height with a load. Do not use the air springs as a means to lift vehicle with no load. This will result in a harsh ride.

SERVICING YOUR VEHICLE WITH AIR SUSPENSION

When lifting the vehicle with a floor jack or hoist on the frame, never allow the air spring to limit the travel of the axle. Try to always jack the vehicle on the axle. Suspending the axle with the air spring limiting the axle travel will damage the air spring and void the air spring warranty.

WARRANTY

To be eligible for warranty, the owner must submit their warranty card or register online within 30 days of the purchase date.

NOTE: The owner's warranty will be void if air springs are run with less than the minimum of 10 psi.

.....