

# Installation Manual

VERSION  
FRANÇAISE



## AIR SUSPENSION KIT

Chevrolet Silverado/GMC Sierra 1500 (2WD/4WD)\*

\* For all truck bed lengths.

\* Will not fit models equipped with Adaptive Ride Control.

**!** Additional 2" spacer kit required for AT4 / Trail Boss applications  
(sold separately – Part No: 10152)

*Use the most advanced air springs on the market to eliminate your vehicle's sag, sway and bottoming out. This heavy duty air suspension kit levels your truck's stance while providing added support for an overall smooth and safe ride.*

\* See application guide for proper fitment.

L6453\_REV9\_03.08.2024

**Thank you and congratulations on the purchase of an Air Suspension kit. Please read the entire manual prior to starting the installation to ensure you can complete it once started.**

## IMPORTANT

This air suspension kit will not increase the GVWR (*Gross Vehicle Weight Rating*), as the GVWR is determined by the vehicle manufacturer. **Do not exceed the maximum capacity listed by the vehicle manufacturer.**

For safe and proper operation of the vehicle, never exceed a maximum of 100PSI in the air springs. Staying under the pressure limit will ensure maximum air spring life. **Failure in doing so may result in damage to your vehicle and/or a void warranty.**

## SAFETY WARNINGS!

**!** Please read and abide the instructions found in this manual, paying close attention to the helpful, cautionary or dangerous warning icons highlighting important safety recommendations and maintenance suggestions throughout this manual.

**+** **HELPFUL INSTALL TIP**  
Additional information that could potentially make the job a little easier.

**!** **PLEASE USE CAUTION**  
Unsafe practices could result in damage to you or your vehicle, or others.

**!** **DANGER WARNING**  
Hazards which could result in severe personal injury or death.

**!** Serious personal injury or death may result from an air spring failure or accident due to improper installation or air spring pressure operation or maintenance.

**!** Inflating an unsecured air spring is dangerous. If it bursts, it could be hurled into the air with explosive force resulting in serious personal injury or death. Never inflate an air spring unless it is secured to the vehicle.

**!** Removing and replacing air springs can be dangerous. This is only a job for a qualified service professional. Never perform air spring service procedures without proper training, tools, and equipment.

## BEFORE STARTING THE INSTALLATION

- Ensure the application information is correct for the make, model and year of the vehicle you are installing the kit on.

**PLEASE BE AWARE:** If this kit is being installed on a **Trail Boss / AT4 model vehicle**, you will need to purchase a 2" Air Suspension Spacer kit (Part # 10152).

- Some vehicles are equipped with a rear wheel brake proportioning valve. Check with the manufacturer before installing the air spring kit, as it may affect braking performance.
- It is recommended to use a good quality anti-seize on all fasteners. This will reduce the chance of corrosion on the fasteners and will help facilitate removal, if required at a later date.

**!** **PLEASE NOTE:** This kit contains **push-to-connect fittings**; using scissors or wire cutters to cut the nylon air line will distort the line and cause the connection to leak. The air line must be cut off squarely with the hose cutter provided in this kit, or a sharp utility knife. **Failure to do so may void the warranty.**



**WARNING:** This product can expose you to the chemical Hexavalent Chromate, which is known to the State of California to cause cancer and birth defects or other reproductive harm. **For more information go to [www.P65Warnings.ca.gov](http://www.P65Warnings.ca.gov)**

**KIT CONTENTS**

Please confirm the items below are provided in your kit before starting the installation. Reference the kit explosion diagram on the following page for part assembly.

HEAVY DUTY KITS		QTY	PART #
A*	Double Convoluted Spring	2	HP10000

HEAVY DUTY JOUNCE BUMPER KITS		QTY	PART #
A*	Double Convoluted Spring w/ Jounce Bumper	2	HP10000J

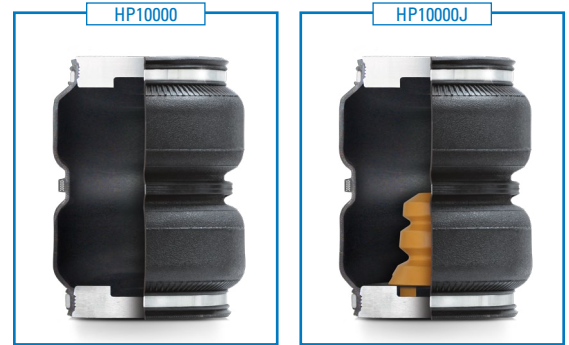

.....

KIT CONTENTS		QTY	PART #
B	Roll Plate	4	HP10054
C	Bracket, Upper	2	HP1578
D	Bracket, Lower	2	HP1579
E	U-Bolt	2	HP1018
F	J-Bolt <sup>o</sup>	6	HP1976
G	Bolt, 3/8" - 24 x 7/8" Hex Head	4	HP1002
H	Bolt, 3/8" - 24 x 3/4" Countersunk	4	HP1008
I	Bolt, 3/8" - 16 x 1.25" Self Threading	2	HP1078
J	Bolt, 1/2" - 13 x 1.5" Self Threading	2	HP1580
K	Washer, 3/8" Flat	4	C653
L	Nut, 3/8" Serrated Flange	10	HP1338
M	90° Swivel Fitting	2	HP1100
N	Heat Shield	1	HP0012
O	Worm Gear Ring Clamp	2	HP1001

.....

**! J-BOLTS:**  
Some kits may include longer J-Bolts (F) that will need to be trimmed flush to the height of the roll plates

**PLEASE BE AWARE:**  
If this kit is being installed on a **Trail Boss / AT4 model vehicle**, you will need to purchase a **2" Air Suspension Spacer kit (Part # 10152)**.

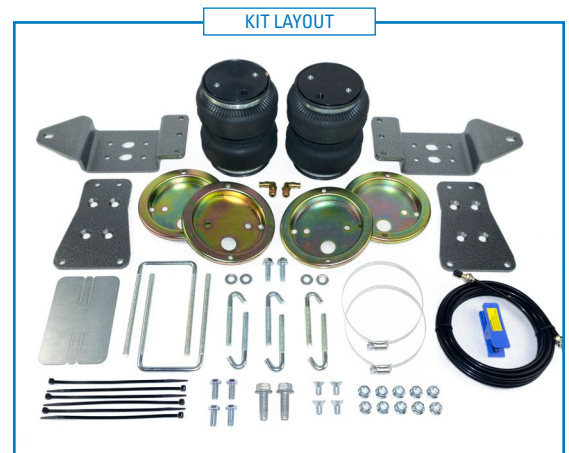

**REQUIRED TOOLS**

- Hoist or Floor Jack
- Safety Stands
- Safety Glasses
- Torque Wrench
- Standard Combination Wrenches
- 7/32" Hex Allen Wrench
- Ratchet
- Metric & Standard Sockets
- Hose Cutter (included) or Sharp Utility Knife
- Pipe Thread Sealant
- Spray Bottle with Dish Soap/Water
- Air Compressor/Compressed Air Source (to test/fill air springs)

**KIT EXPLOSION DIAGRAM**

**DRIVER SIDE ASSEMBLY SHOWN (Passenger side assembly is mirrored)**

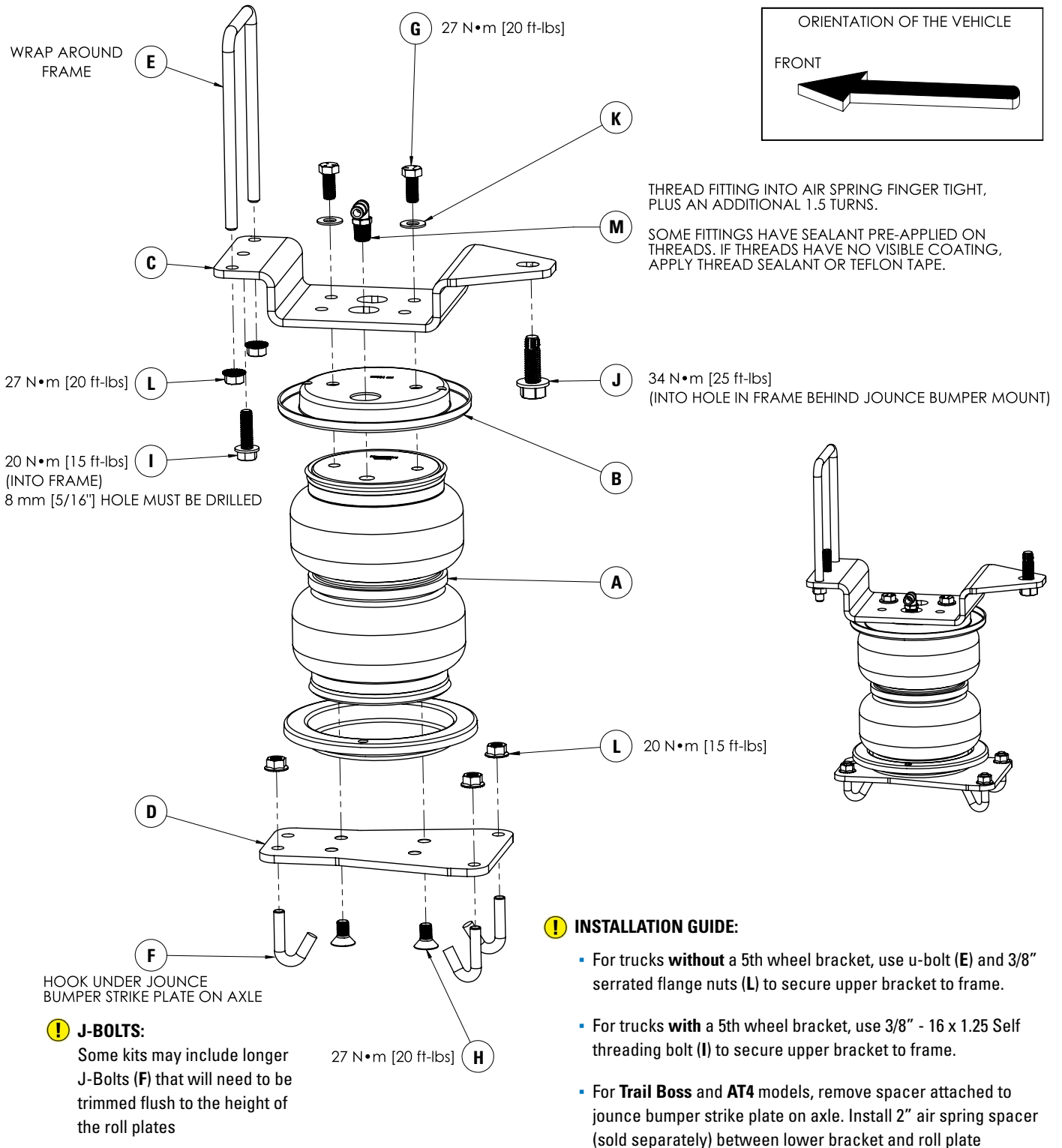

## INSTALLATION INSTRUCTIONS

### 1 REMOVE REAR WHEELS

Place wheel chocks in front of and behind both front wheels.

Raise the rear of the truck high enough to remove both wheels and attain a comfortable working height.

Support vehicle frame on both sides and allow rear suspension to extend.

**+ PLEASE NOTE:** Removing rear wheels is not needed to complete installation, but allows for additional point of accessibility.

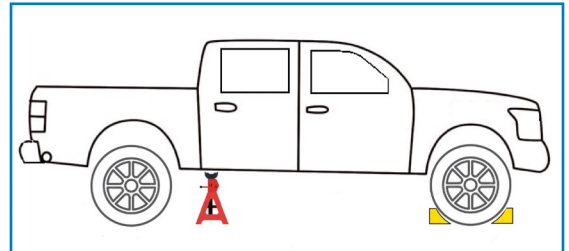

### 2 REMOVE JOUNCE BUMPERS

Remove rear jounce bumpers located on the frame rail on both sides of vehicle using a 10mm socket (see Figure 2).

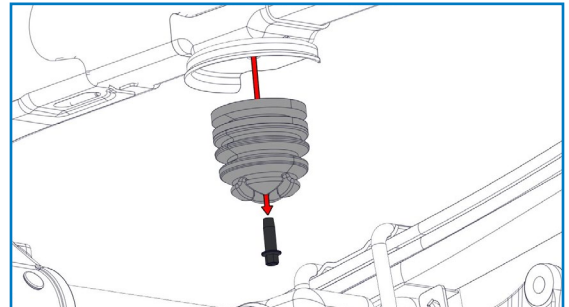

### 3 LOOSEN WIRING HARNESS GUARDS

Locate the wiring harness guard on the front side of the axle below the leaf spring on driver side of the vehicle.

Remove two T40 Torx bolts (as shown in Figure 3) and allow to sit loosely.

**Repeat on the opposite side of the vehicle.**

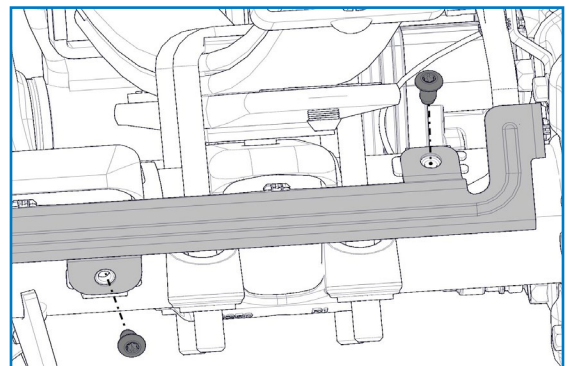

#### 4 ASSEMBLE AIR SPRINGS: UPPER BRACKETS

Put roll plate on top of air spring, ensure that all holes line up.

If 90° air fitting threads do not come with thread sealant pre-applied, apply some now.

Thread fitting into air spring finger tight, then tighten an additional one and half turns. Ensure fitting protrudes less than 1 1/8" from roll plate (as shown in Figure 4A). If not, tighten an additional half turn.

Cut air line assembly into two equal lengths with supplied hose cutter. Connect one section of hose to the fitting on each bag for preliminary leak testing.

- Inflate both air springs to 30 PSI and then use a mixture of dish soap and water on all air line connections to detect any air leaks. Large, expanding bubbles indicate a leak (as shown in Figure 13).
- If leaks at the fitting threads are found, thread in the fitting another half turn.
- If leaks are found around tubing connection, ensure the tubing is clean and pushed completely into port. Gently tug on the tubing outward after inserting fully into the fitting.
- If leaks around the tubing connection or threads continue after these procedures replace the fitting.

**After leak testing the fittings, deflate the bags and remove the air lines before proceeding with installation.**

Arrange the air springs side-by-side with air fittings facing outwards (as shown in Figure 4B).

Note the fitting orientation compared to upper bracket for each air spring.

Attach upper brackets using two 3/8"-24 x 7/8" hex head cap screws and flat washers.

Torque to 27 N•m [20 ft-lbs].

Flip both air springs so that the end without bracket faces up.

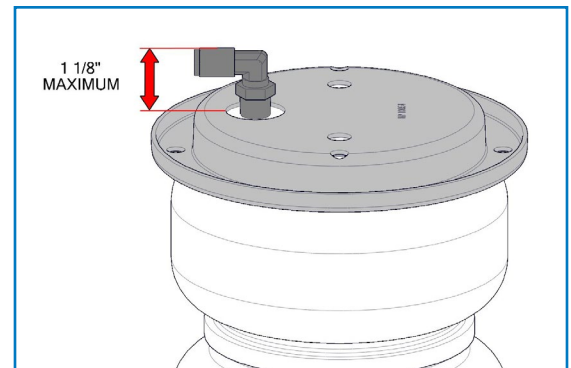

4A

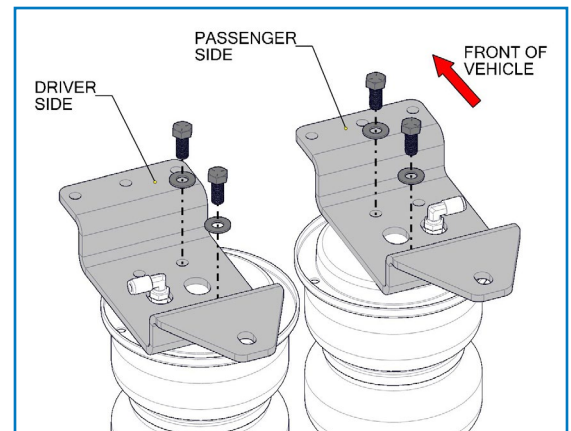

4B

**If installing on a Trail Boss / AT4 model vehicle, you will need to install the 2" Air Suspension Spacer kit (Part # 10152) now, as per the manual included in that kit.**

## 5 ASSEMBLE AIR SPRINGS: LOWER BRACKETS

Set remaining two roll plates on air springs<sup>†</sup>, making sure that all holes line up (larger middle hole for fitting is unused).

**\*PLEASE NOTE: It is not necessary to install the lower roll plate of the air spring kit with the 2" spacer kit mentioned above.**

Set lower brackets on air springs, ensuring offset of the bracket is in same direction as upper bracket (Figure 5).

Secure using two 3/8"-24 x 3/4" flat countersunk cap screws.

Torque to 27 N•m [20 ft-lbs].

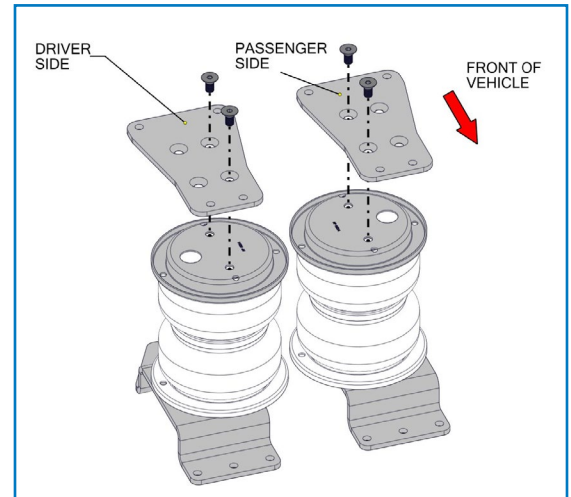

5

## 6 PREPARE FRAME RAIL

Carefully tap existing 11mm hole behind jounce bumper mounting cup with thread-forming bolt.

**! Ensure bolt does not tilt while tightening, threads need to be as straight as possible.**

Stop tightening just before all threads of the bolt are in frame rail and remove bolt.

Coat newly formed threads with anti-seize compound.

**Repeat for opposite side.**

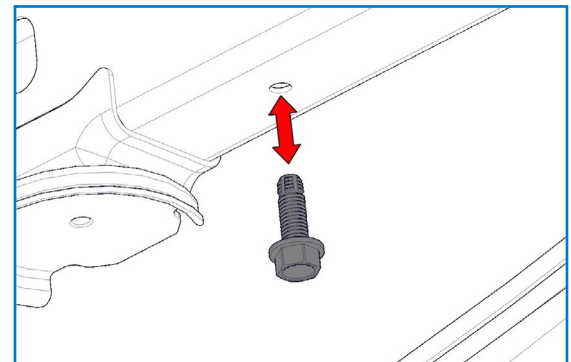

6

## 7 INSTALL AIR SPRING ASSEMBLIES

Set each assembly on jounce bumper strike plate, with air fitting facing the wheel. Ensure wedge-shaped end of upper bracket faces rear of vehicle.

On driver side, hook 3 of J-bolts under jounce bumper strike plate and insert threaded end through corresponding holes of lower bracket (as shown in Figure 7A).

Place flange nut onto each J-bolt so that lower bracket is held loosely to jounce bumper strike plate.

*Step continues on the following page...*

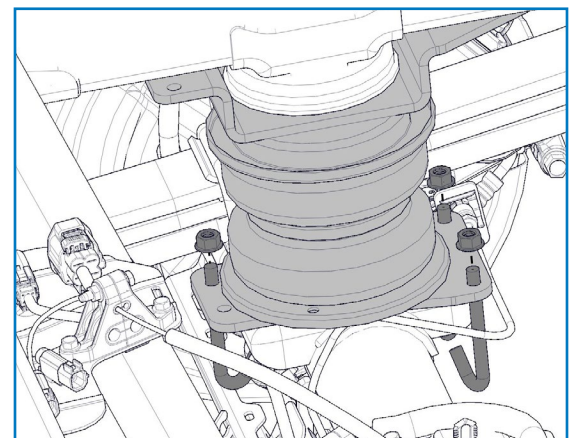

7A

**FOR TRUCKS WITHOUT 5<sup>TH</sup> WHEEL BRACKET**

Slip U-bolt over frame rail on both sides, allowing to hang, forward of jounce bumper mounting cup (as shown in Figure 7B).

**!** *Ensure U-bolt does not pinch brake lines/wiring harness.*

Insert legs of U-bolt into holes of upper bracket and thread on two flange nuts hand tight.

Coat thread-forming bolt with anti-seize and insert into previously tapped hole (see Figure 7C), tighten hand tight.

Torque flange nuts on the lower bracket J-bolts to 20 N•m [15 ft-lbs].

Adjust the upper bracket back and fourth to align the air spring. Some minor misalignment is acceptable.

Torque flange nuts on U-bolts to 27 N•m [20 ft-lbs].

Torque thread-forming bolt to 34 N•m [25 ft-lbs].

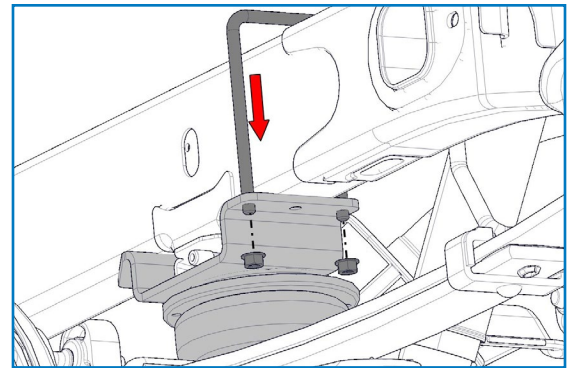

7B

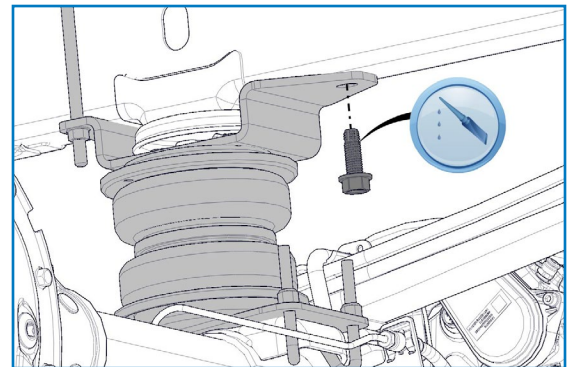

7C

**FOR TRUCKS WITH 5<sup>TH</sup> WHEEL BRACKET**

Coat thread-forming bolt with anti-seize and insert into previously tapped hole (see Figure 7D), tighten to hand tight.

Center upper bracket on frame rail and torque thread-forming bolt to 34 N•m [25 ft-lbs].

Drill 5/16" hole using center hole as guide. (Reference 1, Figure 7E)

Coat 3/8" self-tapping screw with anti-seize and install in 5/16" hole.

Torque to 20 N•m [15ft-lbs]. (Reference 2, Figure 7E)

**Repeat for other side.**

Adjust the upper bracket back and fourth to align the air spring. Some minor misalignment is acceptable.

Torque flange nuts on lower bracket J-bolts to 27 N•m [20 ft-lbs].

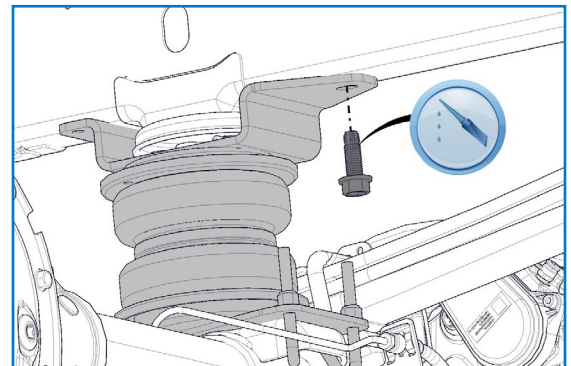

7D

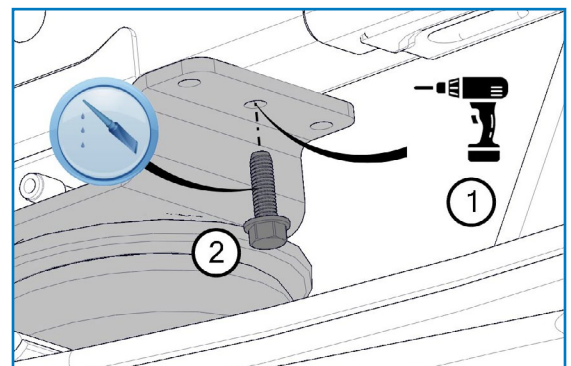

7E



## 8 REINSTALL WIRING HARNESS GUARDS

Reinstall four T40 Torx bolts securing wiring harness guards to front of axle (as shown in Figure 8).

Torque to 20 N•m [15 ft-lbs].

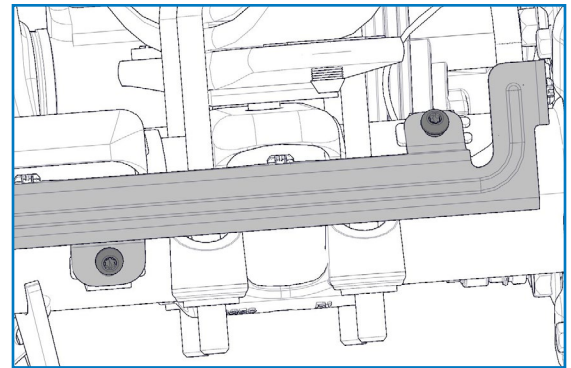

8

## 9 ADJUST BRAKE HARD LINE CLEARANCE

Ensure there is sufficient clearance between the lower bracket & bottom roll plate and the brake hard lines running along the axle on both sides.

- ⚠ **PLEASE NOTE:** If the brake hard line is touching or close to touching air spring components, gently bend the brake hard line away from the air spring components. (see Figure 9)

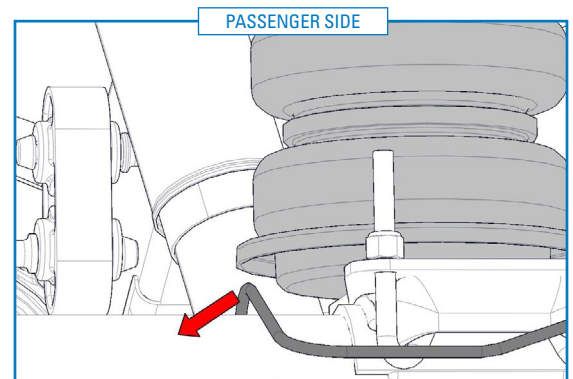

9

## 10 TRIM J-BOLTS

Some kits may contain extended length J-bolts that require trimming. Carefully cut all six J-bolts below the top surface of the lower roll plate as shown in Figure 10.

- ⚠ **WARNING:** If J-bolts extend above the lower roll plate they can touch and abrade the air bag, causing it to fail unexpectedly.

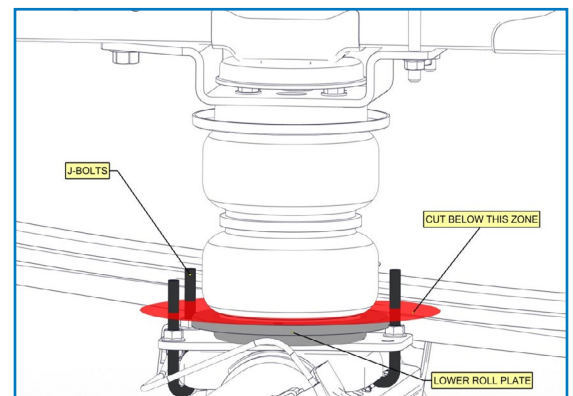

10

## 11 INSTALL HEAT SHIELD

Bend tabs on the heat shield so the required ½" of dead space exists between the heat shield and exhaust when attached.

Attach the heat shield to the exhaust pipe on passenger side using two ring clamps (shown in Figure 11).

Each hose clamp holds a tab against exhaust pipe.

Installation continues on the following page.

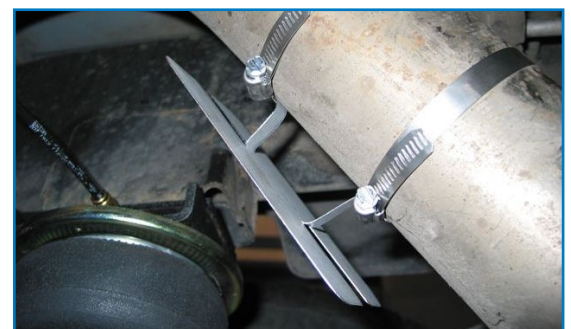

11

## INSTALL AIR LINE

Two fill valves are provided in this kit. The most common place to install them is in place of the license plate fasteners. Alternatively, two 5/16" holes can be drilled in a location of your choosing.

Cut the air line assembly into two equal lengths with the hose cutter provided in this kit or a sharp utility knife.

**⚠ PLEASE NOTE:** *This kit contains push-to-connect fittings; using scissors or wire cutters to cut the nylon air line will distort the line and cause the connection to leak. The air line must be cut off squarely with a hose cutter or a sharp utility knife.*

Install one air line at a time starting at the fill valve location. Place a 5/16" nut on the air valve. Leave enough of the inflation valve in front of the nut to extend through the hole, install a flat washer, and 5/16" nut and cap (reference Figure A for assembly). There should be enough valve exposed after installation – approximately 1/2" – to easily apply a pressure gauge or an air chuck.

Route the air line back to the NPT fitting on the air spring, then cut the hose to length. Moisten the end of the air line prior to inserting it into the fitting and push it in until it stops.

**Repeat with the other fill valve.**

Secure the air lines using the provided tie-straps, away from any moving items and heat sources.

## CHECK SYSTEM FOR LEAKS

Inflate both air springs to 90 psi and then use a mixture of dish soap and water on all air line connections to detect any air leaks. Large, expanding bubbles indicate a leak (as shown in Figure B).

**Repair as necessary and retest.**

Inflate air springs to a predetermined value and on following day recheck pressure. If one or both of air springs have lost pressure, an air leak is present.

**⚠ Leak must be repaired, and then retested until no leaks exist.**

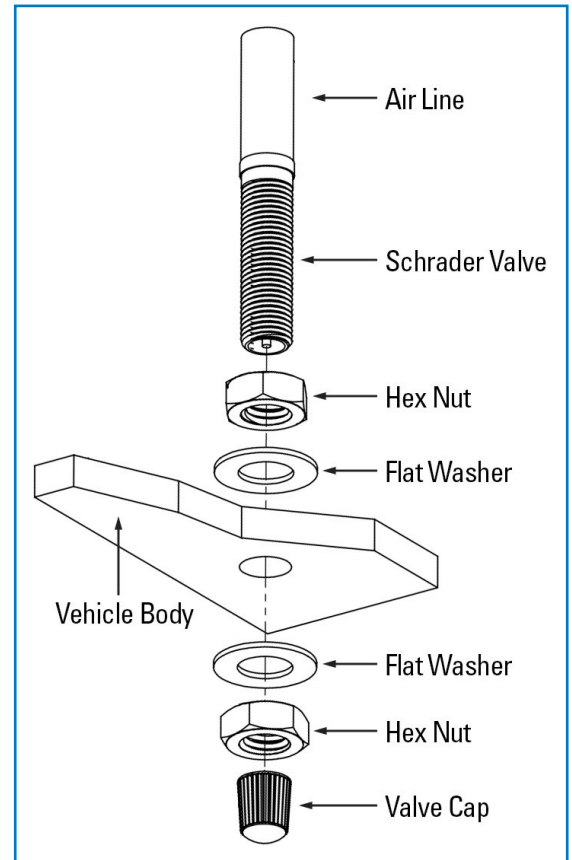

A

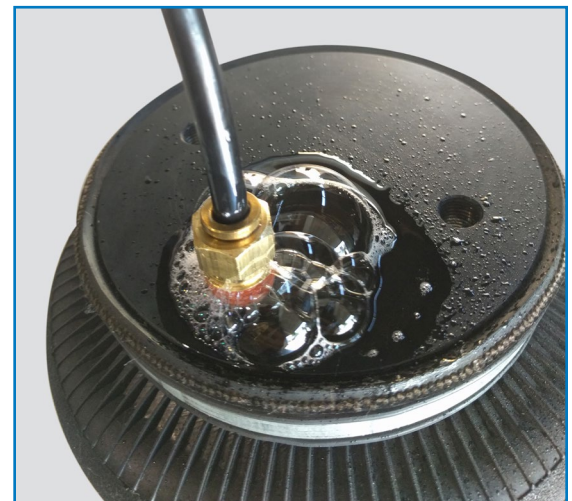

\*Air Spring & NPT Air Fitting may differ between kits

B

**CONGRATULATIONS! You have completed the install**

**After Installation continues on the following page.**

**Thank you again, and congratulations on the installation of your Air Suspension kit.**

**AFTER COMPLETING THE INSTALLATION**

- The air spring must have clearance between itself and the surrounding components to prevent any contact when spring is inflated or compressed. Trimming off excess bolt length may also be required to ensure no contact with the spring or other suspension components can be made once installed.
- If removed, re-install the wheels and torque fasteners to the manufacturer’s specifications. Re-torque all fasteners after the first 500 miles of driving.

**OPERATING YOUR VEHICLE WITH AIR SUSPENSION**

Air springs have minimum and maximum recommended pressure requirements:

PART #	SPRING STYLE	SPRING TYPE	MIN PSI	MAX PSI
HP10189	In-Coil	STANDARD DUTY	5 PSI	70 PSI
HP10560		STANDARD DUTY		
HP10001	Sleeve Style	STANDARD DUTY	10 PSI	100 PSI
HP10173		STANDARD DUTY		
HP10199		STANDARD DUTY		
HP10083	Single Convoluted	HEAVY DUTY	5 PSI	100 PSI
HP10083J		HEAVY DUTY with JOUNCE BUMPER	0 PSI* / 5 PSI	100 PSI
HP10000	Double Convoluted	HEAVY DUTY	5 PSI	100 PSI
HP10000J		HEAVY DUTY with JOUNCE BUMPER	0 PSI* / 5 PSI	100 PSI
HP10068	Large Double Convoluted	HEAVY DUTY	5 PSI	100 PSI
HP10438	Double Convoluted	EXTREME DUTY	5 PSI	100 PSI
HP10438J		EXTREME DUTY with JOUNCE BUMPER	0 PSI* / 5 PSI	100 PSI

*\* Springs with a jounce bumper can be run at zero PSI when vehicle is unloaded only*

For safe and proper operation, never operate the vehicle over the maximum listed PSI in the air springs. Staying under the pressure limit will ensure maximum air spring life. **Failure in doing so may result in damage to your vehicle and/or a void warranty.**

**! It is recommended to check the air pressure in your air springs daily for first couple of days to ensure a leak has not developed.**

Air springs are designed to maintain the vehicle’s stock ride height with a load. Do not use the air springs as a means to lift vehicle with no load. This will result in a harsh ride.

**SERVICING YOUR VEHICLE WITH AIR SUSPENSION**

When lifting the vehicle with a floor jack or hoist on the frame, never allow the air spring to limit the travel of the axle. Try to always jack the vehicle on the axle. Suspending the axle with the air spring limiting the axle travel will damage the air spring and void the air spring warranty.

**WARRANTY**

**See additional warranty included with this kit for details.**