

Installation Manual



10365 KIT

RAM ProMaster Van 1500/2500/3500 (2WD/4WD)*

Use the most advanced air springs on the market to eliminate your vehicle's sag, sway and bottoming out. This heavy duty air suspension kit levels your truck's stance while providing added support for an overall smooth and safe ride.

* See application guide for proper fitment.



WARNING: This product can expose you to the chemical Hexavalent Chromate, which is known to the State of California to cause cancer and birth defects or other reproductive harm. *For more information go to www.P65Warnings.ca.gov*

IMPORTANT

This air suspension kit will not increase the GVWR (*Gross Vehicle Weight Rating*), as the GVWR is determined by the vehicle manufacturer. **Do not exceed the maximum capacity listed by the vehicle manufacturer.**

PLEASE NOTE: *The air bag must have clearance between itself and the surrounding components to prevent any contact when bag is inflated or compressed. Trimming off excess bolt length is also required to ensure no contact with the bag or other suspension components can be made once installed.*

Safety Warnings!

- ❗ Serious personal injury or death may result from an air spring failure or accident due to improper installation or air spring pressure operation or maintenance. Please read and abide the instructions, safety recommendations and maintenance suggestions throughout this manual.
- ❗ Inflating an unsecured air spring is dangerous. If it bursts, it could be hurled into the air with explosive force resulting in serious personal injury or death. Never inflate an air spring unless it is secured to the vehicle.
- ❗ Removing and replacing air springs can be dangerous. This is only a job for a qualified service professional. Never perform air spring service procedures without proper training, tools, and equipment.

KIT CONTENTS

Reference the kit explosion diagram on the following page for part assembly.

| KIT CONTENTS | | QTY | PART # |
|--------------|-------------------------------------|-----|----------|
| A | Single Convoluted Air Spring | 2 | HP10083 |
| B | Roll Plates | 2 | HP10054 |
| C | Upper Frame Bracket | 2 | HP1607 |
| D | Lower Mounting Bracket | 2 | HP1608 |
| E | U-Bolt | 4 | HP1610 |
| F | 3/8" - 24 X 7/8" Hex Head Bolt | 8 | HP1002 |
| G | Hex Head Cap Screw M10 x 1.25 | 2 | HP1609 |
| H | 3/8" Flat Washer | 18 | C18006 |
| I | 3/8" Split Lock Washer | 8 | C18007 |
| J | M10 Split Lock Washer | 2 | C18012 |
| K | 3/8" Nylon Lock Nut | 8 | HP1000 |
| L | 90° Swivel Fitting | 2 | HP1100 |
| M | Heat Shield <i>(not shown)</i> | 1 | HP0012 |
| N | Worm Gear Clamp <i>(not shown)</i> | 2 | HP1001 |
| O | Airline Assembly <i>(not shown)</i> | 1 | HP1344 |
| P | Tie Straps <i>(not shown)</i> | 8 | C11618-8 |
| Q | Hose Cutter <i>(not shown)</i> | 1 | HP10208 |

REQUIRED TOOLS

- Hoist or Floor Jack
- Safety Stands
- Safety Glasses
- Torque Wrench
- Standard Combination Wrenches
- 7/32" Hex Allen Wrench
- 1-1/8" Wrench or Deep Socket
- Ratchet
- Metric & Standard Sockets
- Hose Cutter (included) or Sharp Utility Knife
- Pipe Thread Sealant
- Spray Bottle with Dish Soap/Water
- Air Compressor/Compressed Air Source (to test/fill air springs)

Please make sure all the items shown in this explosion diagram are provided in your kit before starting the installation.

DRIVER SIDE AIR SPRING ASSEMBLY SHOWN:

THREAD FITTING INTO AIR SPRING FINGER TIGHT, PLUS AN ADDITIONAL 1.5 TURNS. SOME FITTINGS HAVE SEALANT PRE-APPLIED ON THREADS. IF THREADS HAVE NO VISIBLE COATING, APPLY THREAD SEALANT OR TEFLON TAPE.

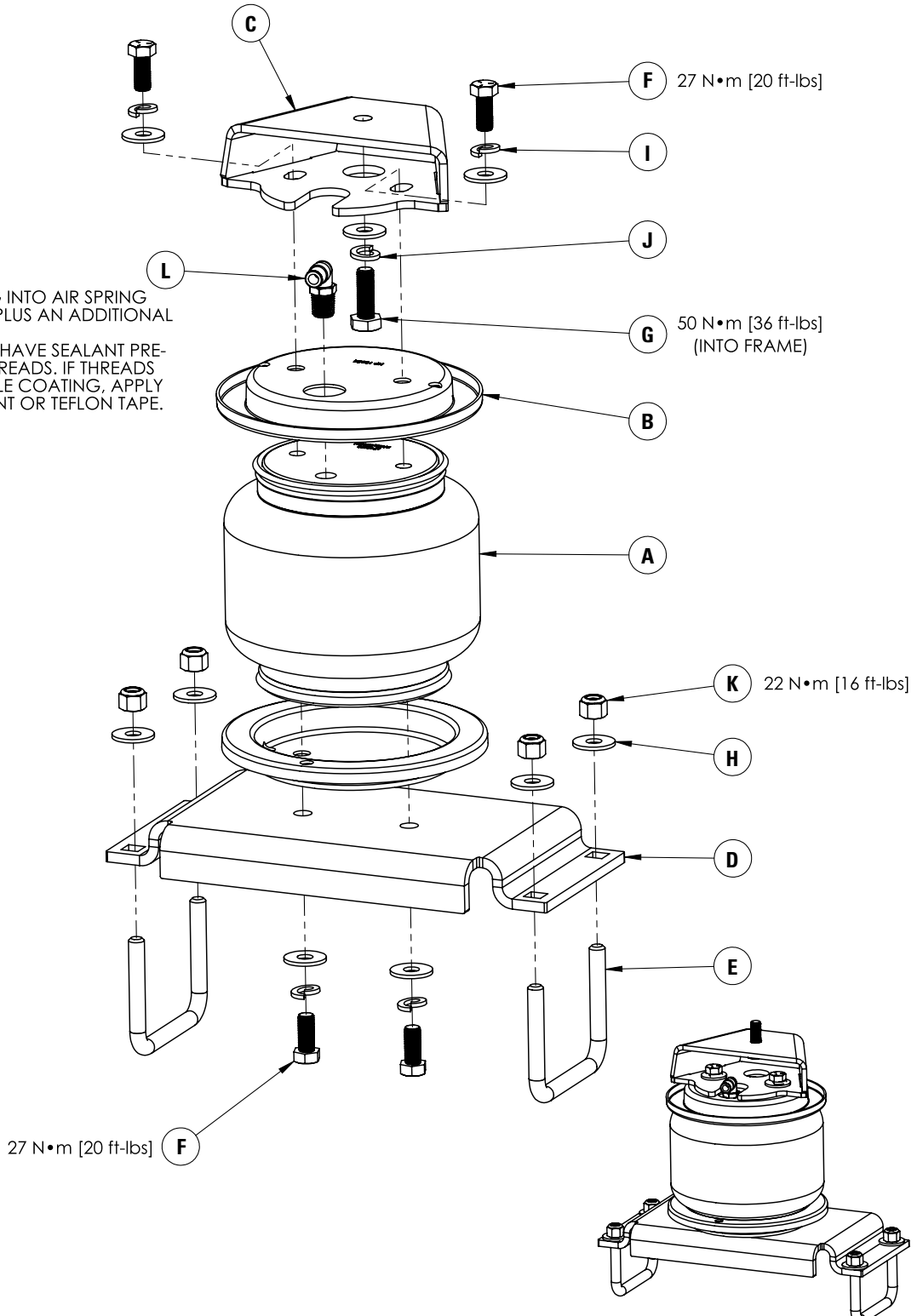

BEFORE STARTING THE INSTALLATION:

1. Ensure the application information is correct for the make, model and year of the vehicle you are installing the kit on.
2. Some vehicles are equipped with a rear wheel brake proportioning valve. Check with the manufacturer before installing the air spring kit, as it may affect braking performance.
3. It is recommended to use a good quality anti-seize on all fasteners. This will reduce the chance of corrosion on the fasteners and will help facilitate removal, if required at a later date.

PLEASE NOTE:

This kit contains push-to-connect fittings; using scissors or wire cutters to cut the nylon airline will distort the line and cause the connection to leak. THE AIRLINE MUST BE CUT OFF SQUARELY WITH THE NYLON HOSE CUTTER PROVIDED IN THIS KIT OR A SHARP UTILITY KNIFE.

1 MEASURE STOCK RIDE HEIGHT

Park the vehicle on a level surface.

Using a measuring tape, measure the distance between the center of the wheel hub and the bottom of the fender well (as shown in Figure 1) this will give you your ride height.

Note the ride height for all four corners.

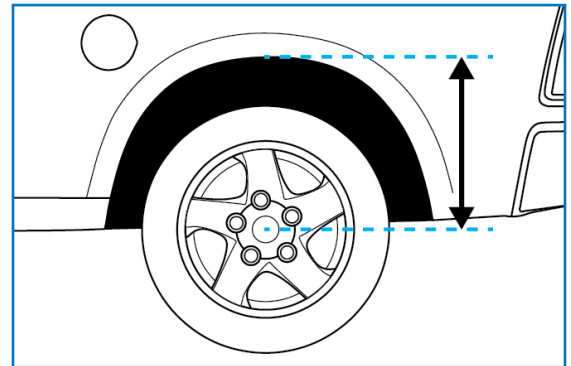

1

2 REMOVE REAR WHEELS

Place wheel chocks in front of and behind both front wheels.

Raise the rear of the truck high enough to remove both wheels and attain a comfortable working height.

Place two jack stands under rear axle (shown in Figure 2).

Lower the vehicle until the axle is supported by the jack stands.

Remove rear wheels.



2

3 REMOVE JOUNCE BUMPERS

Remove the jounce bumper assembly from the frame

Remove the rear spring clips that hold the emergency brake cables onto the spring, rear of the axle

4 ASSEMBLE AIR SPRINGS

Set a roll plate on top of the air spring, ensuring that each hole lines up (as shown in Figure 4A).

Thread the 90° swivel fitting into the top of the air spring, finger tight plus an additional one and a half turns, using a 9/16" socket.

Turn the assembly over and set roll plate on to the bottom of the air spring. Install the lower bracket onto the assembly, making sure that the flange of the lower bracket is on the fitting side of the air spring assembly.

Attach the lower bracket with two 3/8" x 7/8" hex head cap screws, 3/8" lock washers and 3/8" flat washers. Torque the mounting hardware to no more than 27 N•m (20 ft-lbs). (See Figure 4B for reference).



4A

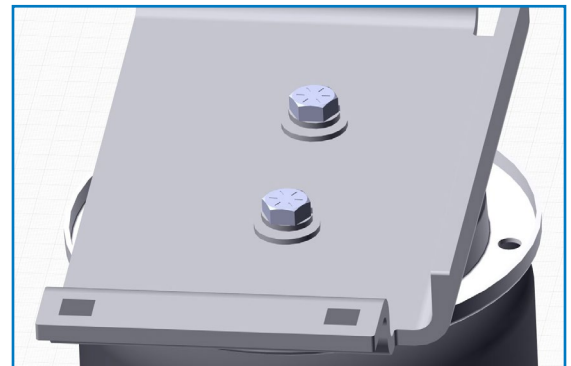

4B

5 INSTALLING THE UPPER BRACKET

Install the upper bracket onto the frame with the M10-1.25 x 30 hex cap screw, M10 lock washer and 3/8" flat washer, using the mounting location where the jounce bumper was previously removed (see Figure 5A).

Align the bracket so that it is parallel to the frame then torque the hardware to 50 N•m (36 ft-lbs).

Note: The bracket must be parallel with the frame before tightening.

Insert two 3/8" x 7/8" hex head cap screws with two 3/8" lock washers and two 3/8" flat washers into the slots in the upper bracket so they face down (see Figure 5B).

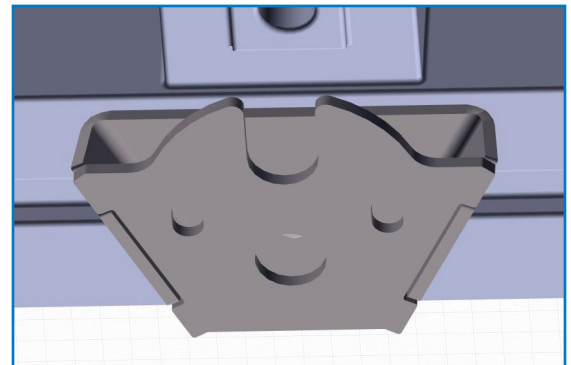

5A

6 INSTALLING THE AIR SPRING ASSEMBLY

Place the assembly onto the leaf springs with the fitting facing inboard.

Raise the axle up so that the top of the air spring assembly is just below the upper bracket. Thread the upper hardware through the roll plate and into the upper spring mount (as shown in Figure 6 on the following page), finger tighten only at this time.

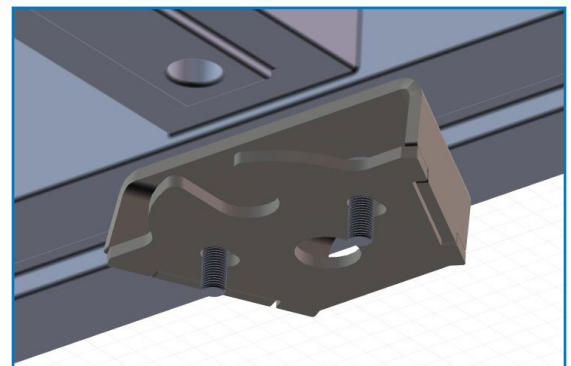

5B

7 INSTALLING THE LOWER BRACKET

Attach the lower bracket to the leaf springs by inserting two U-bolts around the leaf springs and through the lower bracket. Cap with 3/8" flat washers and 3/8" nylon lock nuts.

Push the assembly back or forward to align the air spring perpendicular to the upper mounting and torque the U-bolt hardware to 22 N•m (16 ft-lbs).

Push the top of the air spring assembly in and out to align the air spring perpendicular to the lower bracket, then torque the upper mounting to no more than 27 N•m (20 ft-lbs).

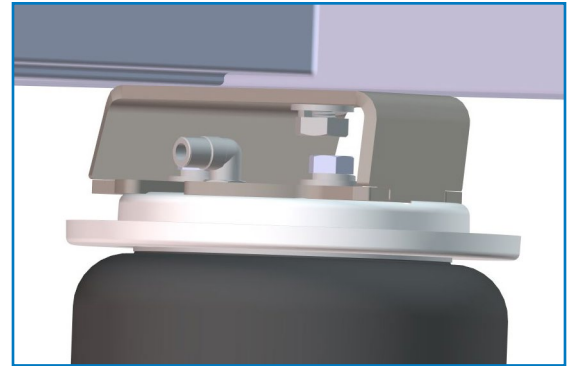

6

8 INSTALL HEAT SHIELD

Bend tabs on the heat shield so the required 1/2" of dead space exists between the heat shield and exhaust when attached.

Attach the heat shield to the exhaust pipe on passenger side using two ring clamps (shown in Figure 8).

Each hose clamp holds a tab against exhaust pipe.

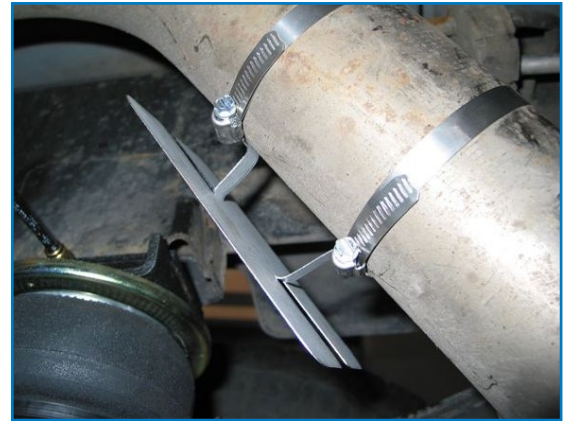

8

9 INSTALL AIR LINE

PLEASE NOTE: This kit contains push-to-connect fittings; using scissors or wire cutters to cut the nylon airline will distort the line and cause the connection to leak. THE AIRLINE MUST BE CUT OFF SQUARELY WITH THE NYLON HOSE CUTTER PROVIDED IN THIS KIT OR A SHARP UTILITY KNIFE

Provided in air spring kit are two fill valves. The most common place to install is in place of license plate fasteners. Alternatively, two 5/16" holes can be drilled in a convenient location.

Cut air line assembly into two equal lengths with hose cutter.

Install one air line, route the nylon air line to an air spring fitting and cut the hose. Moisten the end of the air line prior to inserting it into the fitting and push it in until it stops. Repeat with the other fill valve.

Secure airlines using the tie-straps, away from moving items and heat sources.

Place a 5/16" nut on the air valve. Leave enough of the inflation valve in front of the nut to extend through the hole, install a flat washer, and 5/16" nut and cap (reference Figure 9 for assembly). There should be enough valve exposed after installation—approximately 1/2"—to easily apply a pressure gauge or an air chuck.

If an in-cab inflation kit is being installed, follow the instructions provided with that kit now.

10 CHECK SYSTEM FOR LEAKS

Inflate both air springs to 90 psi and then use a mixture of dish soap and water on all air line connections to detect any air leaks. Large, expanding bubbles indicate a leak (as shown in Figure 10). Repair as necessary and retest.

Inflate air springs to a predetermined value and on following day recheck pressure. If one or both of air springs have lost pressure, an air leak is present. Leak must be repaired, and then retested until no leaks exist.

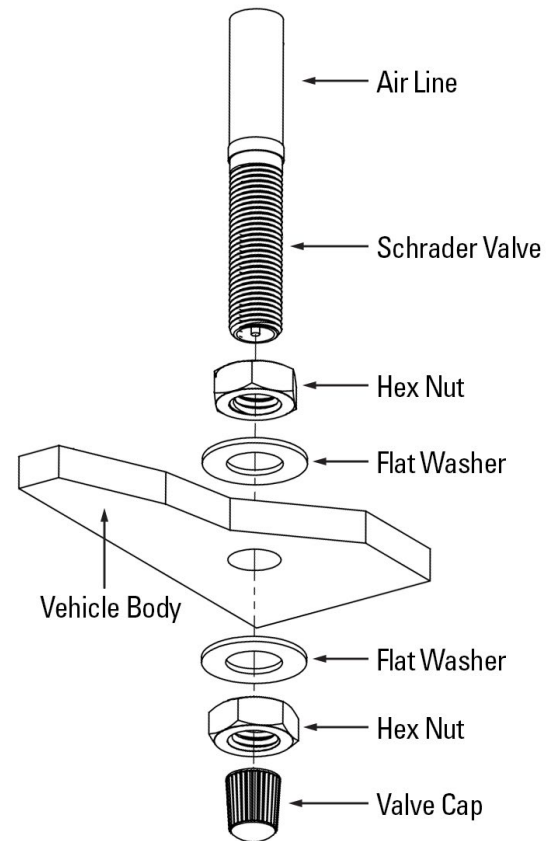

9



10

11 AFTER COMPLETING THE INSTALLATION

PLEASE REMEMBER:

Install wheels and torque fasteners to manufacturer's specifications.

Re-torque all fasteners after first 500 miles of driving.

For safe and proper operation, never operate the vehicle under minimum of 10 psi or over maximum of 100 psi in air springs. Staying within pressure limit will ensure maximum air spring life. Failure in doing so may result in a void warranty.

 ***Do not exceed maximum vehicle payload. Failure to do so may result in failure of the air suspension kit and/or damage to your vehicle.***

.....

Thank you again, and congratulations on the installation of the air suspension kit.

OPTIONAL ACCESSORIES

Optional dual needle air gauges are available to monitor pressure in each spring from vehicle cab, as well as a full line of air compressors, air tanks, and solenoids built to work with and control your air spring system.

OPERATING YOUR VEHICLE WITH AIR SUSPENSION

Air springs have minimum and maximum pressure requirements. Never operate your vehicle with less than 10 psi in air spring and never inflate air springs over 100 psi. Damage to air springs will result.

Check air pressure in air springs daily for first couple of days to ensure a leak has not developed. Air springs are designed to maintain the vehicles stock ride height with a load. Do not use the air springs as a means to lift vehicle with no load. This will result in a harsh ride.

SERVICING YOUR VEHICLE WITH AIR SUSPENSION

When lifting the vehicle with a floor jack or hoist on the frame, never allow the air spring to limit the travel of the axle. Try to always jack the vehicle on the axle. Suspending the axle with the air spring limiting the axle travel will damage the air spring and void the air spring warranty.

WARRANTY

The owner's warranty will be void if air springs are run with less than the minimum of 10 psi. See additional warranty for details.

.....