

# Installation Manual

VERSION  
FRANÇAISE



## 10370 KIT

Ford E450 Cab-Chassis & Class C Motorhome\*

*Use the most advanced air springs on the market to eliminate your vehicle's sag, sway and bottoming out. This heavy duty air suspension kit levels your truck's stance while providing added support for an overall smooth and safe ride.*

\* See application guide for proper fitment.



**WARNING:** This product can expose you to the chemical Hexavalent Chromate, which is known to the State of California to cause cancer and birth defects or other reproductive harm. *For more information go to [www.P65Warnings.ca.gov](http://www.P65Warnings.ca.gov)*

***Thank you and congratulations on the purchase of an air suspension kit. Please read the entire manual prior to starting the installation to ensure you can complete it once started.***

**IMPORTANT**

This air suspension kit will not increase the GVWR (*Gross Vehicle Weight Rating*), as the GVWR is determined by the vehicle manufacturer. **Do not exceed the maximum capacity listed by the vehicle manufacturer.**

***PLEASE NOTE: The air bag must have clearance between itself and the surrounding components to prevent any contact when bag is inflated or compressed. Trimming off excess bolt length is also required to ensure no contact with the bag or other suspension components can be made once installed.***

*Safety Warnings!*

- ❗ Serious personal injury or death may result from an air spring failure or accident due to improper installation or air spring pressure operation or maintenance. Please read and abide the instructions, safety recommendations and maintenance suggestions throughout this manual.
- ❗ Inflating an unsecured air spring is dangerous. If it bursts, it could be hurled into the air with explosive force resulting in serious personal injury or death. Never inflate an air spring unless it is secured to the vehicle.
- ❗ Removing and replacing air springs can be dangerous. This is only a job for a qualified service professional. Never perform air spring service procedures without proper training, tools, and equipment.



**KIT CONTENTS**

*Reference the kit explosion diagram on the following page for part assembly.*

<b>KIT CONTENTS</b>		<b>QTY</b>	<b>PART #</b>
<b>A</b>	Air Bag	2	HP10000
<b>B</b>	Roll Plate	4	HP10054
<b>C</b>	Lower Bracket Assembly	2	HP1635
<b>D</b>	Bracket, Upper Driver	1	HP1639
<b>E</b>	Bracket, Upper Passenger	1	HP1640
<b>F</b>	Bracket, Upper Driver Support	1	HP1641
<b>G</b>	Bracket, Upper Passenger Support	1	HP1642
<b>H</b>	Axle Strap	2	HP1406
<b>I</b>	U-Bolt	2	HP1486
<b>J</b>	3/8" – 24 X 7/8" Hex Head Bolt	4	HP1002
<b>K</b>	3/8" – 24 X 3/4" Countersunk Bolt	4	HP1008
<b>L</b>	3/8" – 16 X 1.25" Hex Head Bolt	8	C10464
<b>M</b>	3/8" – 16 X 1.75" Hex Head Bolt	2	HP1227
<b>N</b>	3/8" – 16 X 7" Carriage Bolt	4	HP1409
<b>O</b>	5/16" – 18 X 1" Flange Bolt	2	C11819
<b>P</b>	5/16" Flat Washer	2	C11944
<b>Q</b>	3/8" Flat Washer	30	C653
<b>R</b>	3/8" Lock Washer	4	C18007
<b>S</b>	5/16" Nylon Lock Nut	2	C11943
<b>T</b>	3/8" Nylon Lock Nut	16	HP1000
<b>U</b>	3/8" Serrated Flange Nut	2	HP1338
<b>V</b>	90° Swivel Fitting	2	HP1100
<b>W</b>	Heat Shield	1	HP0012
<b>X</b>	Worm Gear Ring Clamp	2	HP1001

**REQUIRED TOOLS**

- Hoist or Floor Jack
- Safety Stands
- Safety Glasses
- Torque Wrench
- Standard Combination Wrenches
- 7/32" Hex Allen Wrench
- 1-1/8" Wrench or Deep Socket
- Ratchet
- Metric & Standard Sockets
- Hose Cutter (included) or Sharp Utility Knife
- Pipe Thread Sealant
- Spray Bottle with Dish Soap/Water
- Air Compressor/Compressed Air Source (to test/fill air springs)

Please make sure all the items shown in this explosion diagram are provided in your kit before starting the installation.

**DRIVER SIDE ASSEMBLY SHOWN:**

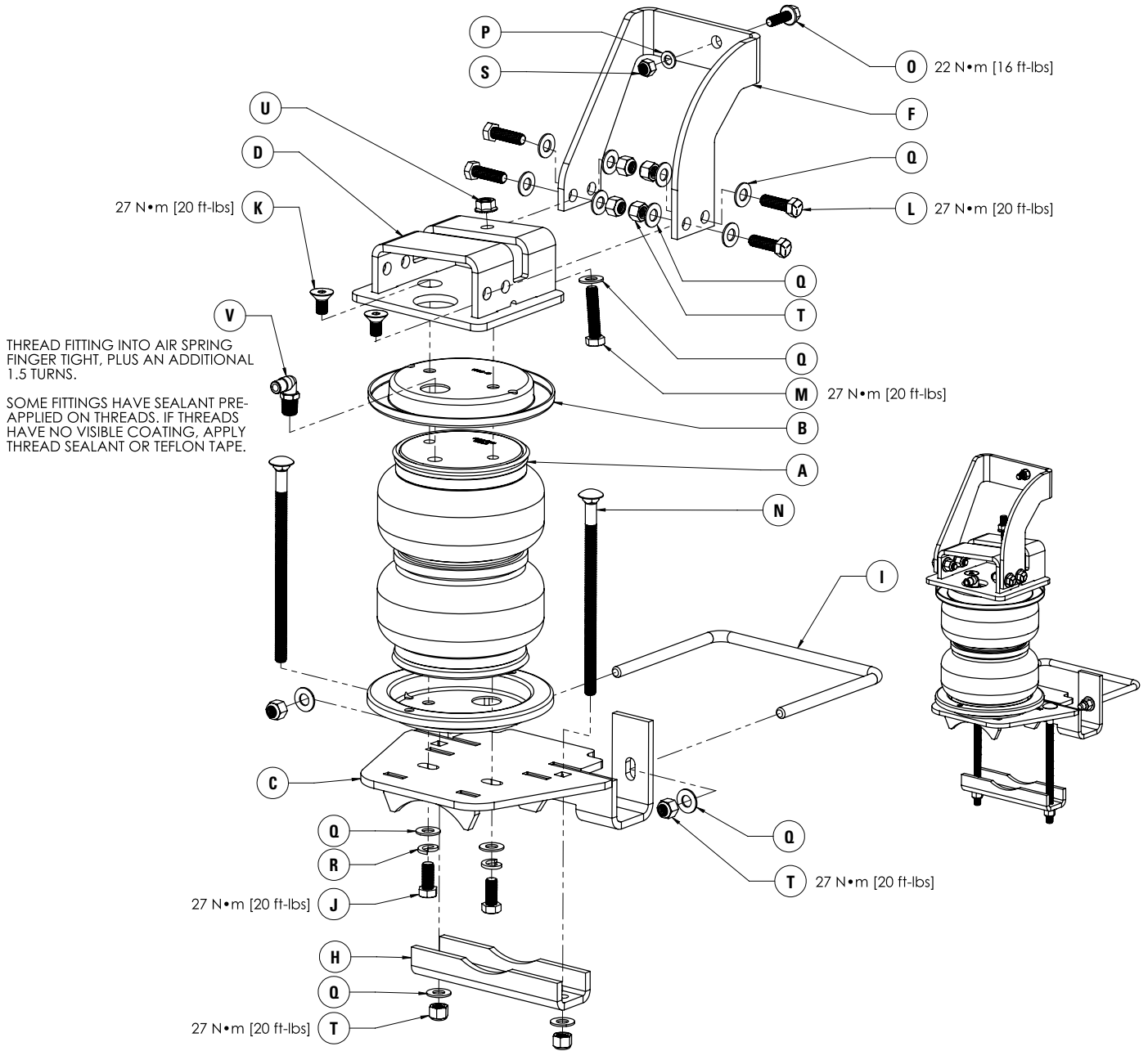

**BEFORE STARTING THE INSTALLATION:**

1. Ensure the application information is correct for the make, model and year of the vehicle you are installing the kit on.
2. Some vehicles are equipped with a rear wheel brake proportioning valve. Check with the manufacturer before installing the air spring kit, as it may affect braking performance.
3. It is recommended to use a good quality anti-seize on all fasteners. This will reduce the chance of corrosion on the fasteners and will help facilitate removal, if required at a later date.

**PLEASE NOTE:**

***This kit contains push-to-connect fittings; using scissors or wire cutters to cut the nylon airline will distort the line and cause the connection to leak. THE AIRLINE MUST BE CUT OFF SQUARELY WITH THE NYLON HOSE CUTTER PROVIDED IN THIS KIT OR A SHARP UTILITY KNIFE.***

**1 MEASURE STOCK RIDE HEIGHT**

Park the vehicle on a level surface.

Using a measuring tape, measure the distance between the center of the wheel hub and the bottom of the fender well (as shown in Figure 1) this will give you your ride height.

Note the ride height for all four corners.

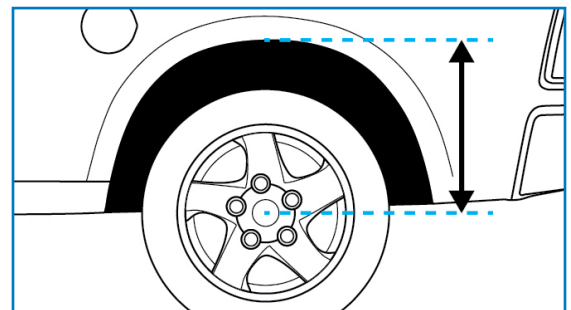

1

**2 REMOVE REAR WHEELS**

Place wheel chocks in front of and behind both front wheels.

Raise the rear of the truck high enough to remove both wheels and attain a comfortable working height.

Place two jack stands under rear axle (shown in Figure 2).

Lower the vehicle until the axle is supported by the jack stands.

Remove rear wheels.



2

**3 REMOVE JOUNCE BUMPER**

Remove the flange nut securing the jounce bumper to frame rail using a 17 mm socket.

Remove the jounce bumpers (as shown in Figure 3) and discard the nuts as they will not be reused in this installation.

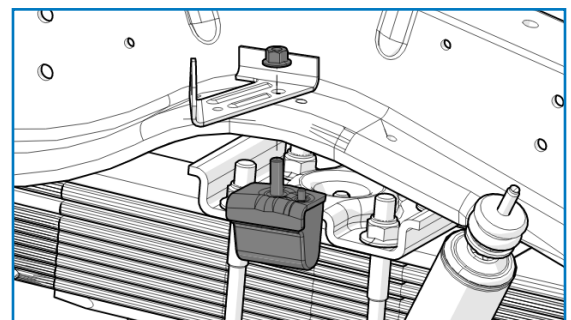

3

#### 4 ATTACH LOWER BRACKETS

Using Figure 4 as reference: place roll plate on bottom of air spring.

Set lower bracket on roll plate with bent flanges positioned opposite of air inlet hole.

Secure using two 3/8" – 24 x 7/8" Hex Head Bolts, two 3/8" lock washers and two 3/8" flat washers

Do not fully tighten to allow air spring alignment in Step 9.

#### 5 INSTALL UPPER ROLL PLATE & AIR FITTING

Set roll plate on top of air spring

Install 90° swivel fitting into air spring as shown in Figure 5.

Thread swivel fitting finger tight plus an additional 1.5 turns. Use of thread sealant or Teflon tape is recommended.

#### 6 ATTACH UPPER BRACKETS

Install a 3/8" – 16 x 1.75" Hex Head Bolt and 3/8" flat washer in each upper bracket as shown in Figure 6A.

Set upper bracket on roll plate and secure to airbag with two 3/8" – 24 x 3/4" Countersunk Bolts as shown in Figure 6B on the following page.

Torque bolts to 20 ft-lbs (27 N•m).

Refer to Figure 6C (on the following page) and note the orientations of the upper brackets as these determine which side of the vehicle the assembly must be installed on.

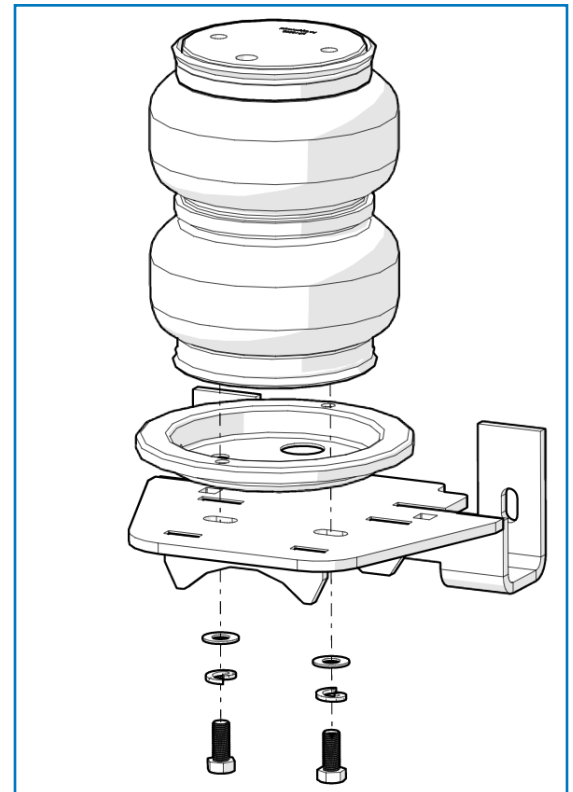

4

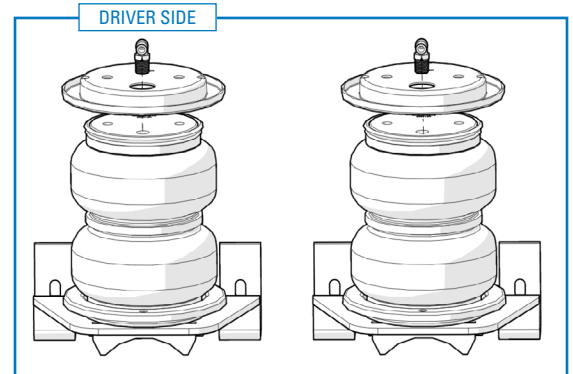

5

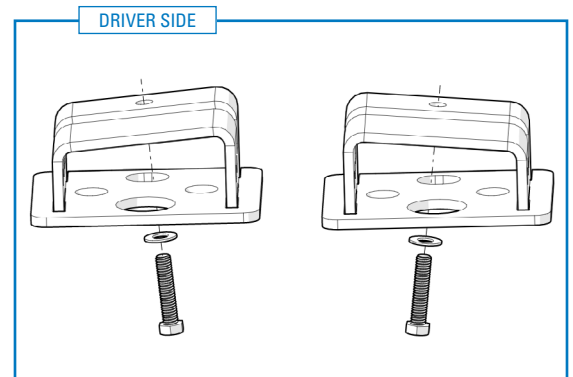

6A



## 7 INSTALL AIR SPRING ASSEMBLIES

Install the air spring assembly in the vehicle as shown in Figure 7.

The lower bracket will sit on the axle and the upper bracket will sit with the rectangular slot cradling the downward bent flange of the frame above the axle.

On the driver's side of the vehicle, ensure the lower bracket sits in a way that does not interfere with the axle vent line (circled in red in Figure 7).

Insert the 3/8" – 16 x 1.75" bolt, installed earlier, through the hole previously used by the jounce bumper.

On the driver's side, ensure the bolt also passes through the brake line bracket secured with the jounce bumper.

Secure upper bracket using a 3/8" Serrated Flange Nut.

Torque flange nut to 20 ft-lbs (27 N•m)

## 8 INSTALL UPPER SUPPORT BRACKETS

On the driver's side, install the driver support bracket as shown in Figure 8A.

**The bracket must sit as follows:**

- The **rearward** flange must be **under** all brake, fuel and electrical lines
- The **forward** flange must be **over** all brake, fuel and electrical lines, except for the line supported by the brake line bracket

It is recommended to hook the rear flange under the lines in the position indicated by the red arrow, then slide and twist the bracket into place.

On the passenger side, there are no interfering lines. Set the passenger support bracket in place on the frame.

*Continued on following page...*

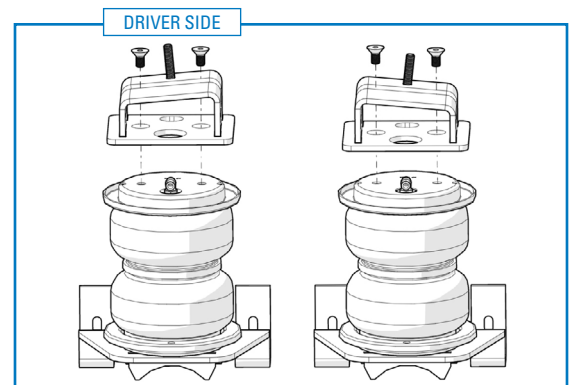

6B

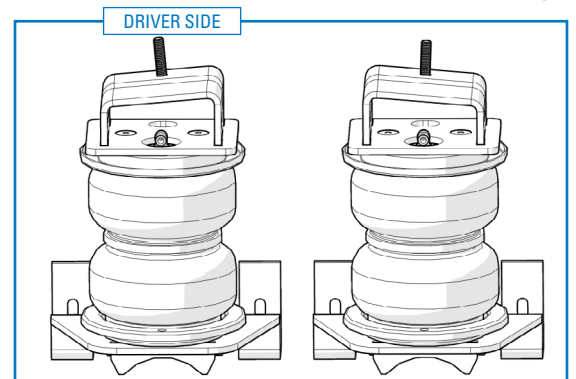

6C

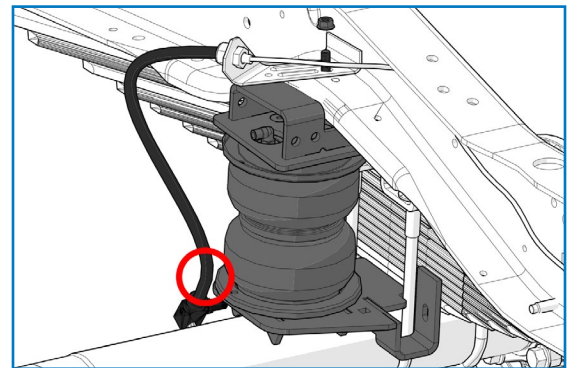

7

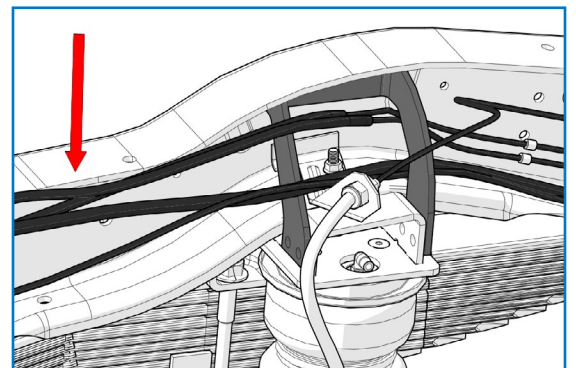

8A

Secure both support brackets to the upper brackets as shown in Figure 8B using four 3/8" – 16 x 1.25" Hex Head Bolts, four 3/8" nylon lock nuts and eight 3/8" flat washers.

Torque hardware to 20 ft-lbs (27 N•m)

Secure both support brackets to the frame using a 5/16" – 18 x 1" Flange Bolt, 5/16" flat washer and 5/16" nylon lock nut.

Torque hardware to 16 ft-lbs (22 N•m)

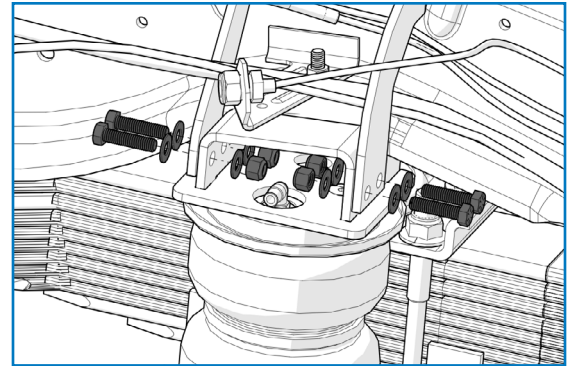

8B

## 9 SECURE LOWER BRACKET

Insert two 3/8" – 16 x 7" carriage bolts through the square holes in the lower bracket as shown in Figure 9A.

Attach an axle strap to the carriage bolts as shown in Figure 9B using two 3/8" flat washers and two 3/8" nylon lock nuts

Do not fully tighten yet

Install the U-bolt around the leaf pack and into the lower bracket as shown in 9C. Secure with two 3/8" flat washers and two 3/8" nylon lock nuts.

Torque the axle strap lock nuts to 20 ft-lbs (27 N•m)

Torque the U-Bolt lock nuts to 20 ft-lbs (27 N•m)

Position the airbag on the lower bracket to achieve the best vertical alignment (see step 9D for correct air spring alignment).

Torque the air bag bolts to 20 ft-lbs (27 N•m)

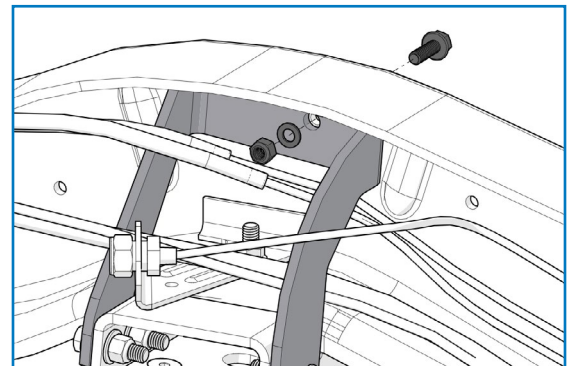

8C

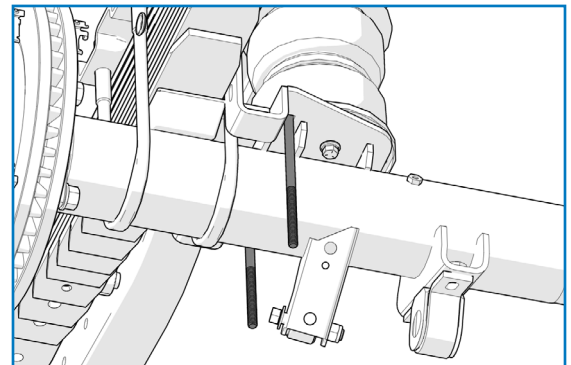

9A

## 10 INSTALL HEAT SHIELD

Bend tabs on the heat shield so the required 1/2" of dead space exists between the heat shield and exhaust when attached.

Attach the heat shield to the exhaust pipe on passenger side using two ring clamps (shown in Figure 10 on following page). Each hose clamp holds a tab against exhaust pipe.

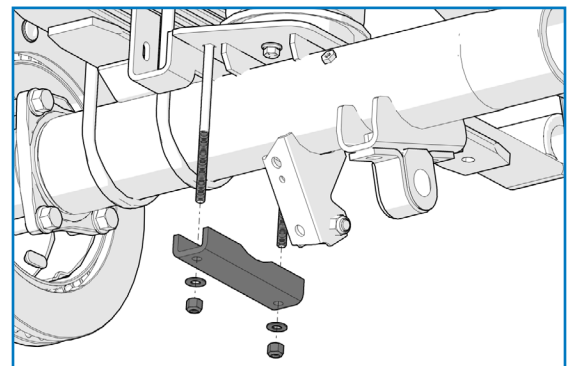

9B



## 11 INSTALL AIR LINE

**PLEASE NOTE:** This kit contains push-to-connect fittings; using scissors or wire cutters to cut the nylon airline will distort the line and cause the connection to leak. THE AIRLINE MUST BE CUT OFF SQUARELY WITH THE NYLON HOSE CUTTER PROVIDED IN THIS KIT OR A SHARP UTILITY KNIFE

Provided in air spring kit are two fill valves. The most common place to install is in place of license plate fasteners. Alternatively, two 5/16" holes can be drilled in a convenient location.

Cut air line assembly into two equal lengths with hose cutter.

Install one air line, route the nylon air line to an air spring fitting and cut the hose. Moisten the end of the air line prior to inserting it into the fitting and push it in until it stops. Repeat with the other fill valve.

Secure airlines using the tie-straps, away from moving items and heat sources.

Place a 5/16" nut on the air valve. Leave enough of the inflation valve in front of the nut to extend through the hole, install a flat washer, and 5/16" nut and cap (reference Figure 11 on following page for assembly). There should be enough valve exposed after installation—approximately 1/2"—to easily apply a pressure gauge or an air chuck.

**If an in-cab inflation kit is being installed, follow the instructions provided with that kit now.**

## 12 CHECK SYSTEM FOR LEAKS

Inflate both air springs to 90 psi and then use a mixture of dish soap and water on all air line connections to detect any air leaks. Large, expanding bubbles indicate a leak (as shown in Figure 12 on following page). Repair as necessary and retest.

Inflate air springs to a predetermined value and on following day recheck pressure. If one or both of air springs have lost pressure, an air leak is present. Leak must be repaired, and then retested until no leaks exist.

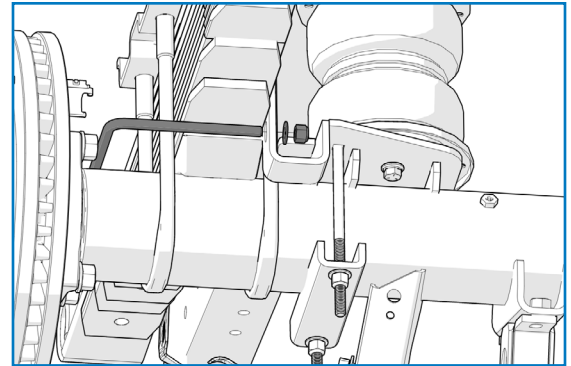

9C

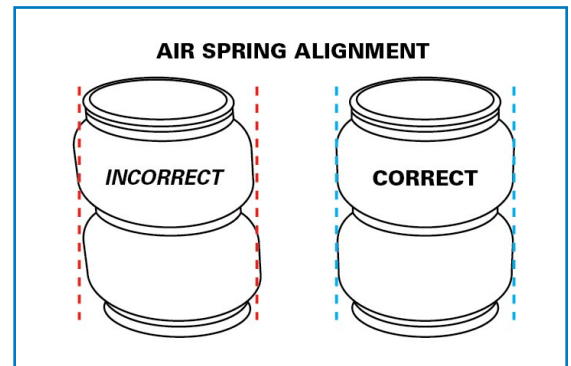

9D

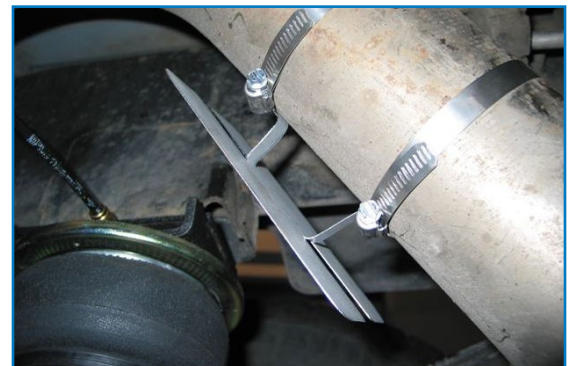

10

### 13 AFTER COMPLETING THE INSTALLATION

**PLEASE REMEMBER:**

Install wheels and torque fasteners to manufacturer's specifications.

Re-torque all fasteners after first 500 miles of driving.

For safe and proper operation, never operate the vehicle under minimum of 10 psi or over maximum of 100 psi in air springs. Staying within pressure limit will ensure maximum air spring life. Failure in doing so may result in a void warranty (see **Note** below).

**NOTE: Do not exceed maximum vehicle payload. Failure to do so may result in failure of the air suspension kit and/or damage to your vehicle.**

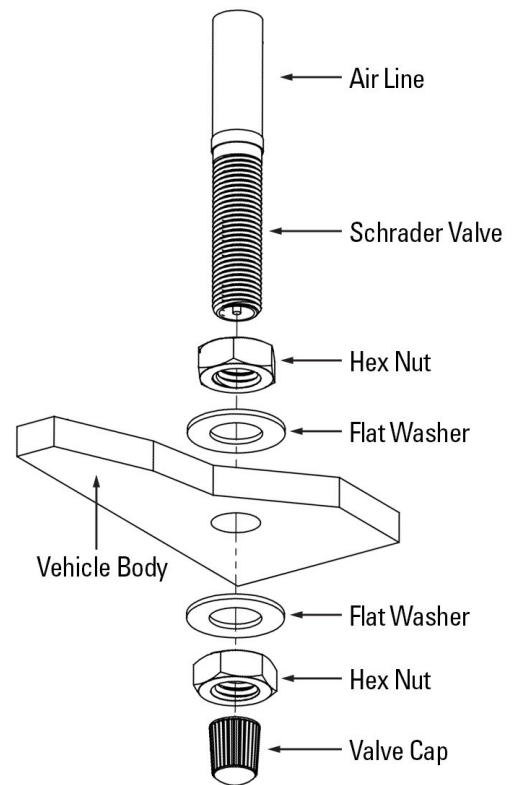

11



12

***Thank you again, and congratulations on the installation of the air suspension kit.***

**OPTIONAL ACCESSORIES**

Optional dual needle air gauges are available to monitor pressure in each spring from vehicle cab, as well as a full line of air compressors, air tanks, and solenoids built to work with and control your air spring system.

**OPERATING YOUR VEHICLE WITH AIR SUSPENSION**

Air springs have minimum and maximum pressure requirements. Never operate your vehicle with less than 10 psi in air spring and never inflate air springs over 100 psi. Damage to air springs will result.

Check air pressure in air springs daily for first couple of days to ensure a leak has not developed. Air springs are designed to maintain the vehicles stock ride height with a load. Do not use the air springs as a means to lift vehicle with no load. This will result in a harsh ride.

**SERVICING YOUR VEHICLE WITH AIR SUSPENSION**

When lifting the vehicle with a floor jack or hoist on the frame, never allow the air spring to limit the travel of the axle. Try to always jack the vehicle on the axle. Suspending the axle with the air spring limiting the axle travel will damage the air spring and void the air spring warranty.

**WARRANTY**

***The owner's warranty will be void if air springs are run with less than the minimum of 10 psi. See additional warranty for details.***

