

Installation Manual

VERSION
FRANÇAISE



AIR SPRING KIT

RAM 4500 / 5500 Cab & Chassis (2WD/4WD)*

Eliminate your vehicle's sag, sway and bottoming out while providing added support for an overall smooth and safe ride with this extreme duty air suspension kit. Rated for up to 7500 lbs of load-leveling capacity⁺, this kit is ideally suited for those towing/hauling big loads on a regular basis.

* See application guide for proper fitment.

+ Applications vary. Never exceed manufacturer's recommended Gross Vehicle Weight Rating



WARNING: This product can expose you to the chemical Hexavalent Chromate, which is known to the State of California to cause cancer and birth defects or other reproductive harm. *For more information go to www.P65Warnings.ca.gov*

IMPORTANT

This air suspension kit will not increase the GVWR (*Gross Vehicle Weight Rating*), as the GVWR is determined by the vehicle manufacturer. **Do not exceed the maximum capacity listed by the vehicle manufacturer.**

PLEASE NOTE: *The air bag must have clearance between itself and the surrounding components to prevent any contact when bag is inflated or compressed. Trimming off excess bolt length is also required to ensure no contact with the bag or other suspension components can be made once installed.*

Safety Warnings!

- ❗ Serious personal injury or death may result from an air spring failure or accident due to improper installation or air spring pressure operation or maintenance. Please read and abide the instructions, safety recommendations and maintenance suggestions throughout this manual.
- ❗ Inflating an unsecured air spring is dangerous. If it bursts, it could be hurled into the air with explosive force resulting in serious personal injury or death. Never inflate an air spring unless it is secured to the vehicle.
- ❗ Removing and replacing air springs can be dangerous. This is only a job for a qualified service professional. Never perform air spring service procedures without proper training, tools, and equipment.

KIT CONTENTS

Reference the kit explosion diagram on the following page for part assembly.

KIT CONTENTS		QTY	PART #
A	Extreme Duty Air Spring	2	HP10438
B	Roll Plate	4	HP10069
C	Bracket, Upper Support	2	HP1643
D	Bracket, Upper Frame Mounting	2	HP1644
E	Bracket, Upper Spring Mounting	2	HP1645
F	Bracket, Lower	2	HP1520
G	Axle Strap	2	HP1383
H	Bolt, 3/8" – 24 x 7/8" Hex Head	8	HP1002
I	Bolt, 3/8" – 16 x 1.5" Hex Head	20	HP1646
J	Bolt, 3/8" – 16 X 1.25" Carriage	8	HP1149
K	Bolt, 3/8" – 16 X 7" Carriage	4	HP1409
L	Bolt, M10 x 1.5 x 35mm Hex Head	4	HP1134
M	Washer, 3/8" Flat (Small)	4	C653
N	Washer, 3/8" Flat	48	C18006
O	Nut, 3/8" Nylon Lock	28	HP1000
P	Nut, 3/8" Serrated Flange	4	HP1338
Q	Fitting, 90° Brass Air	2	HP1245
R	Heat Shield	1	HP0012
S	Worm Gear Ring Clamp	2	HP1001

REQUIRED TOOLS

- Hoist or Floor Jack
- Safety Stands
- Safety Glasses
- Torque Wrench
- Standard Combination Wrenches
- 7/32" Hex Allen Wrench
- 1-1/8" Wrench or Deep Socket
- Ratchet
- Metric & Standard Sockets
- Hose Cutter (included) or Sharp Utility Knife
- Pipe Thread Sealant
- Spray Bottle with Dish Soap/Water
- Air Compressor/Compressed Air Source (to test/fill air springs)

BEFORE STARTING THE INSTALLATION:

1. Ensure the application information is correct for the make, model and year of the vehicle you are installing the kit on.
2. Some vehicles are equipped with a rear wheel brake proportioning valve. Check with the manufacturer before installing the air spring kit, as it may affect braking performance.
3. It is recommended to use a good quality anti-seize on all fasteners. This will reduce the chance of corrosion on the fasteners and will help facilitate removal, if required at a later date.

PLEASE NOTE:

This kit contains push-to-connect fittings; using scissors or wire cutters to cut the nylon airline will distort the line and cause the connection to leak. THE AIRLINE MUST BE CUT OFF SQUARELY WITH THE NYLON HOSE CUTTER PROVIDED IN THIS KIT OR A SHARP UTILITY KNIFE.

1 MEASURE STOCK RIDE HEIGHT

Park the vehicle on a level surface. Remove any unnecessary weight from the vehicle to attain a Normal Ride Height. This is important for correct initial air spring set-up and adjustment.

Using a measuring tape, measure the distance between the center of the wheel hub and the bottom of the fender well (as shown in Figure 1) this will give you your ride height.

Note the ride height for all four corners.

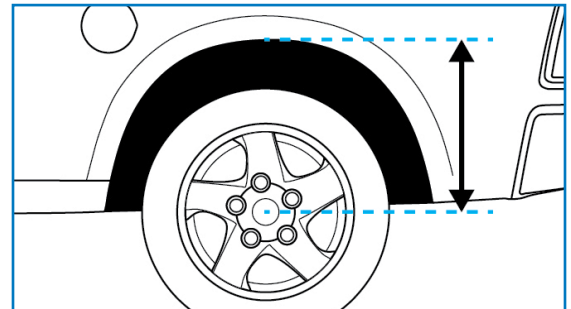

1

2 REMOVE REAR WHEELS

Place wheel chocks in front of and behind both front wheels.

Raise the rear of the truck high enough to remove both wheels and attain a comfortable working height.

Place two jack stands under rear axle (shown in Figure 2).

Lower the vehicle until the axle is supported by the jack stands.

Remove rear wheels.

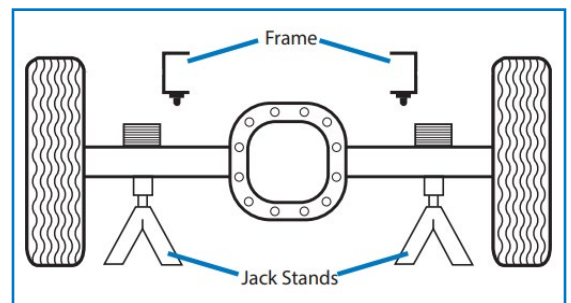

2

3 REMOVE JOUNCE BUMPER

Remove the two bolts securing the jounce bumper to frame.

Remove the jounce bumpers and discard the bolts as they will not be reused in this installation.

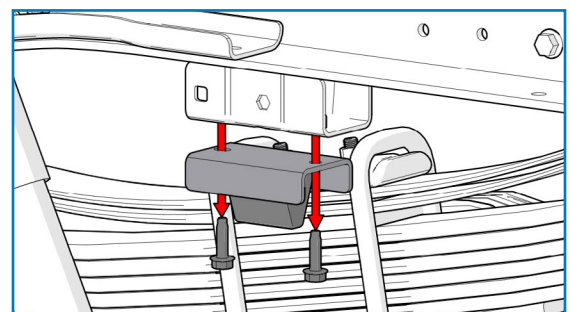

3

4 ATTACH THE UPPER FRAME BRACKET

Fasten the upper frame bracket to the vehicle by inserting two M10 x 1.5 x 35mm hex bolts through the bracket as shown into the holes previously occupied by the jounce bumper hardware.

Torque the bolts to 30 ft-lbs (40 N•m).

NOTE: When installed, the top surface of the bracket will not rest against the bottom surface of the jounce bumper mount. This gap is intentional as the jounce bumper mount cannot support the load transferred through the spring.

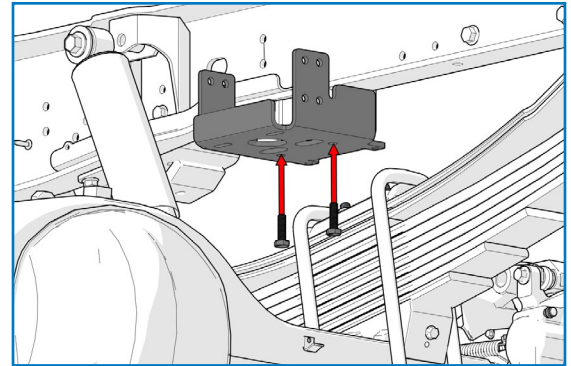

4

5 MARK HOLES FOR UPPER SUPPORT BRACKET

Place the upper support bracket in position on the vehicle frame (as shown in Figure 5A).

On the driver's side, fuel lines will need to be unclipped and moved downwards for proper fitment.

Two mounting holes must be drilled through the frame in the indicated locations (see Figure 5B).

NOTE: On some vehicles, it may be necessary to modify or remove an exhaust hanger mount on the passenger side if there is interference with the support bracket.

Position the upper support bracket so the upper bracket surface rests flat against the top of the frame channel (as in Figure 5B) and the back surface rests flat against the rear of the frame channel.

Using the bracket as a template, mark the center points of the mounting holes to be drilled.

IMPORTANT:

The upper support bracket MUST rest flat against the vehicle frame as shown before marking holes to be drilled. Incorrect placement of the bracket may result in kit failure or vehicle damage during use.

Remove the upper support bracket and drill two 13/32" holes through the frame in the marked positions.

Use caution to not damage any brake, fuel or electrical lines during drilling.

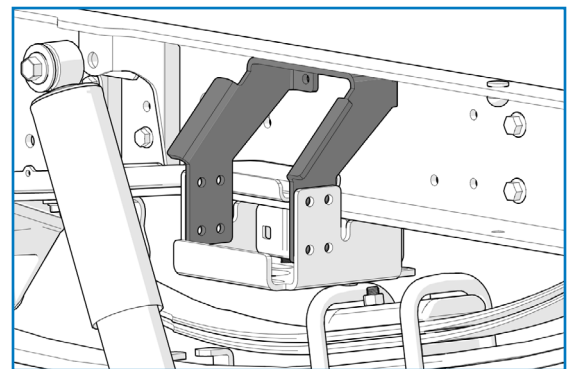

5A

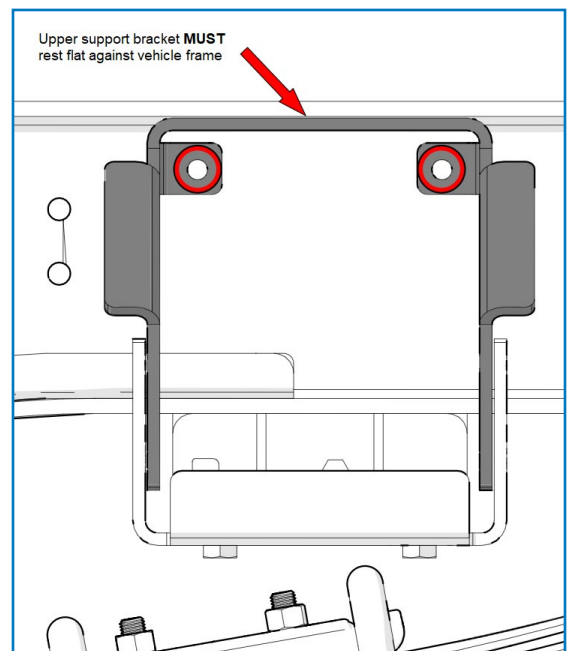

5B

6 ATTACH UPPER SUPPORT BRACKET

Clear any metal shavings or debris before placing the upper support bracket in the vehicle.

Line up the holes in the upper support bracket with the drilled holes in the frame and holes in the upper frame bracket.

Attach the bracket (as shown in Figures 6A and 6B) using (10) 3/8" – 16 X 1.5" bolts, (20) 3/8" flat washers and (10) 3/8" nylon lock nuts.

Torque the two bolts securing the bracket to the frame first to 40 ft-lbs (54 N•m).

Torque the remaining eight bolts evenly to 40 ft-lbs (54 N•m).

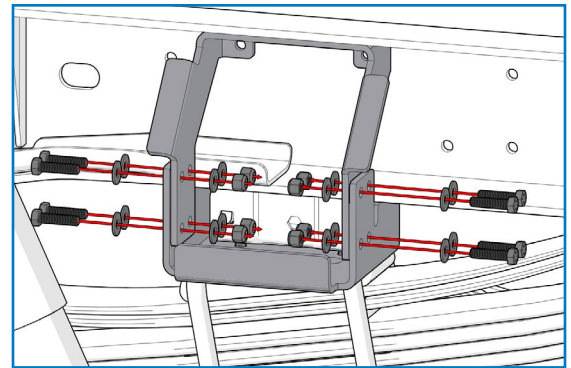

6A

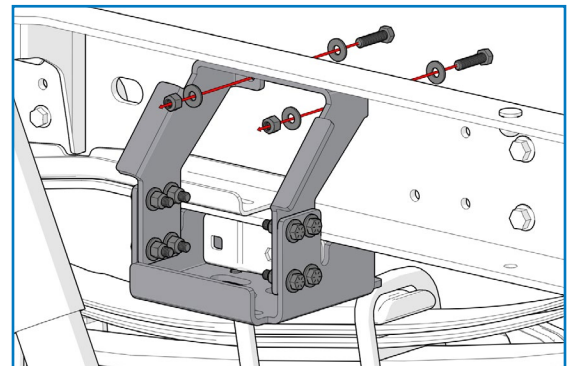

6B

7 ASSEMBLE SPRINGS AND UPPER BRACKETS

Install the air fitting into the port on the top of the air spring. Tighten the fitting finger tight plus an additional 1.5 turns. The use of Teflon tape or thread sealant is recommended.

Insert two 3/8" – 16 x 1.25" carriage bolts through the square holes as shown in Figure 7.

NOTE: Carriage bolts must be inserted through bracket before attaching bracket to spring as the roll plate will block the holes.

Set a roll plate and the upper spring bracket on the top surface of the air spring. Ensure all holes are aligned and install two 3/8" – 24 x 7/8" hex head bolts.

Torque bolts to 20 ft-lbs (27 N•m).

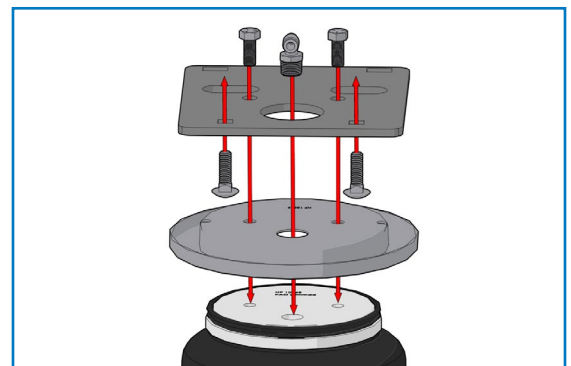

7

8 ASSEMBLE SPRINGS AND LOWER BRACKETS

Insert two 3/8" – 16 x 7" carriage bolts through the lower brackets (as shown in Figure 8A). Ensure the bolts are inserted through the indicated holes.

Set a roll plate on the bottom surface of the air spring, followed by the lower brackets with carriage bolts as shown.

Note the orientations of the lower brackets relative to the air inlet port (as shown in Figure 8B on the following page). **Incorrect bracket orientation will result in installation issues.**

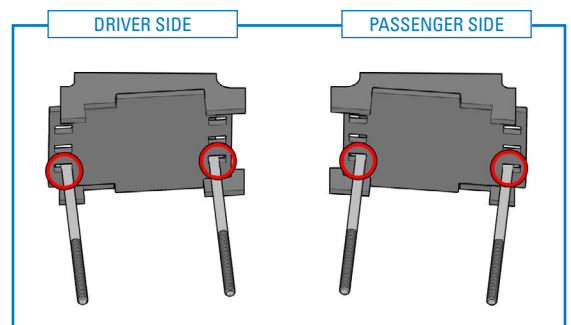

8A

Step continues on following page...

Ensure all holes are aligned and secure with two 3/8" – 24 x 7/8" hex head bolts and two small 3/8" flat washers.

The final spring assemblies will appear as shown in Figure 8C.

9 INSTALL SPRING ASSEMBLY

NOTE: It may be necessary to raise the frame a few inches to provide adequate clearance for installation.

Install the spring assemblies into the vehicle (as shown in Figure 9A).

Insert the two previously installed carriage bolts through the holes in the upper frame bracket and secure the assembly using two more 3/8" – 16 x 1.25" carriage bolts, four 3/8" flat washers and four 3/8" nylon lock nuts (see Figure 9B on this page and Figure 9C on following page for reference).

Do not fully tighten hardware at this time to allow for spring alignment.

PLEASE NOTE: It may also be necessary to remove the emergency brake line from the axle clip if interference occurs with the lower bracket.

10 INSTALL AXLE STRAP

Secure the lower bracket to the axle with an axle strap and two 3/8" serrated flange nuts.

Do not fully tighten hardware at this time to allow for spring alignment

11 ALIGN SPRING ASSEMBLIES

Adjust the upper spring bracket and lower bracket on the axle to best align the air springs (see Figure 11 on following page for reference).

When alignment is achieved, torque hardware as follows:

- Torque the four 3/8" nylon lock nuts on the upper bracket assembly to 20 ft-lbs (27 N•m).
- Torque the two 3/8" serrated flange nuts on the axle strap to 20 ft-lbs (27 N•m).

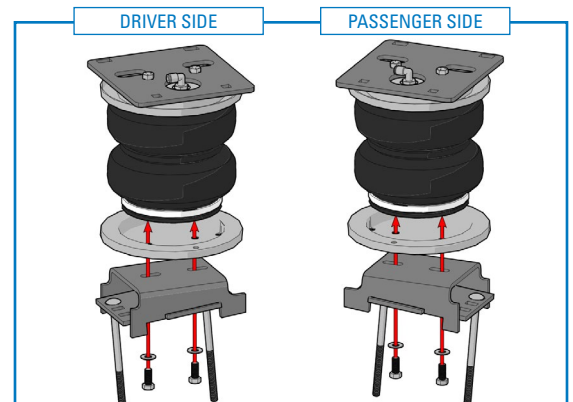

8B

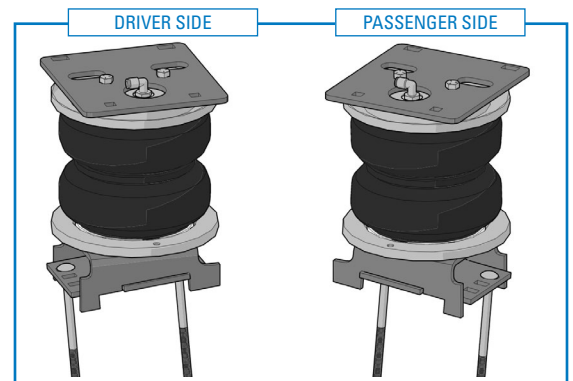

8C

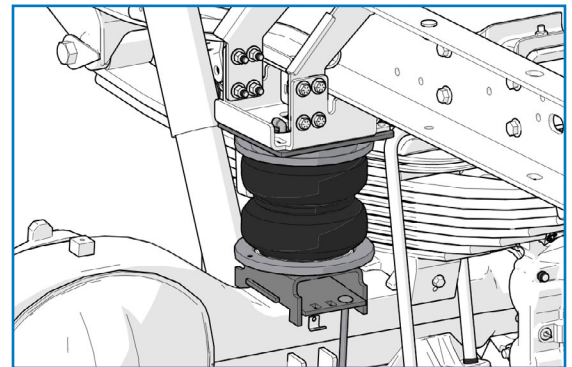

9A

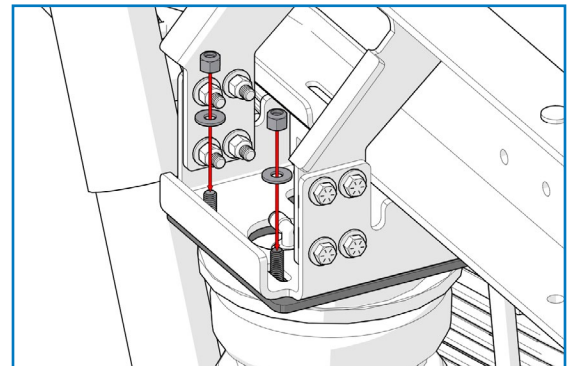

9B

12 INSTALL HEAT SHIELD

Bend tabs on the heat shield so the required $\frac{1}{2}$ " of dead space exists between the heat shield and exhaust when attached.

Attach the heat shield to the exhaust pipe on passenger side using two ring clamps (shown in Figure 12). Each hose clamp holds a tab against exhaust pipe.

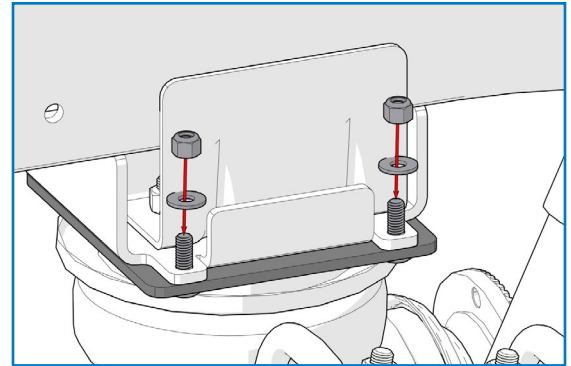

9C

13 INSTALL AIR LINE

PLEASE NOTE: This kit contains push-to-connect fittings; using scissors or wire cutters to cut the nylon airline will distort the line and cause the connection to leak. THE AIRLINE MUST BE CUT OFF SQUARELY WITH THE NYLON HOSE CUTTER PROVIDED IN THIS KIT OR A SHARP UTILITY KNIFE

Provided in air spring kit are two fill valves. The most common place to install is in place of license plate fasteners. Alternatively, two $\frac{5}{16}$ " holes can be drilled in a convenient location.

Cut air line assembly into two equal lengths with hose cutter.

Install one air line, route the nylon air line to an air spring fitting and cut the hose. Moisten the end of the air line prior to inserting it into the fitting and push it in until it stops. Repeat with the other fill valve.

Secure airlines using the tie-straps, away from moving items and heat sources.

Place a $\frac{5}{16}$ " nut on the air valve. Leave enough of the inflation valve in front of the nut to extend through the hole, install a flat washer, and $\frac{5}{16}$ " nut and cap (reference Figure 13 on following page for assembly).

There should be enough valve exposed after installation—approximately $\frac{1}{2}$ "—to easily apply a pressure gauge or an air chuck.

If an in-cab inflation kit is being installed, follow the instructions provided with that kit now.

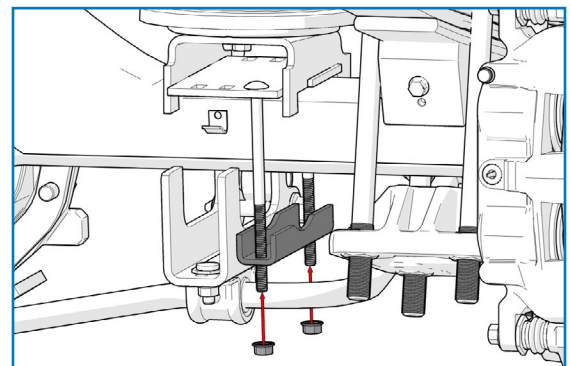

10

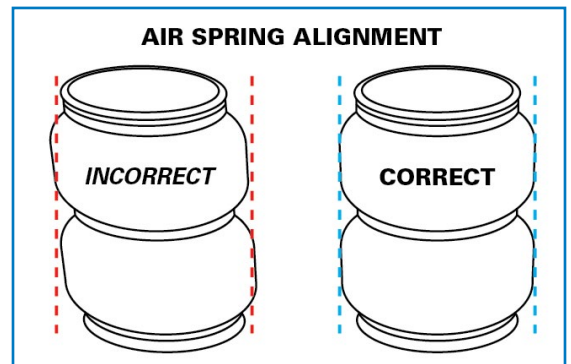

11



12

14 CHECK SYSTEM FOR LEAKS

Inflate both air springs to 90 psi and then use a mixture of dish soap and water on all air line connections to detect any air leaks. Large, expanding bubbles indicate a leak (as shown in Figure 14). Repair as necessary and retest.

Inflate air springs to a predetermined value and on following day recheck pressure. If one or both of air springs have lost pressure, an air leak is present. Leak must be repaired, and then retested until no leaks exist.

15 AFTER COMPLETING THE INSTALLATION

PLEASE REMEMBER:

Install wheels and torque fasteners to manufacturer's specifications.

Re-torque all fasteners after first 500 miles of driving.

For safe and proper operation, never operate the vehicle under minimum of 10 psi or over maximum of 100 psi in air springs. Staying within pressure limit will ensure maximum air spring life. Failure in doing so may result in a void warranty.

⚠ Do not exceed maximum vehicle payload. Failure to do so may result in failure of the air suspension kit and/or damage to your vehicle.

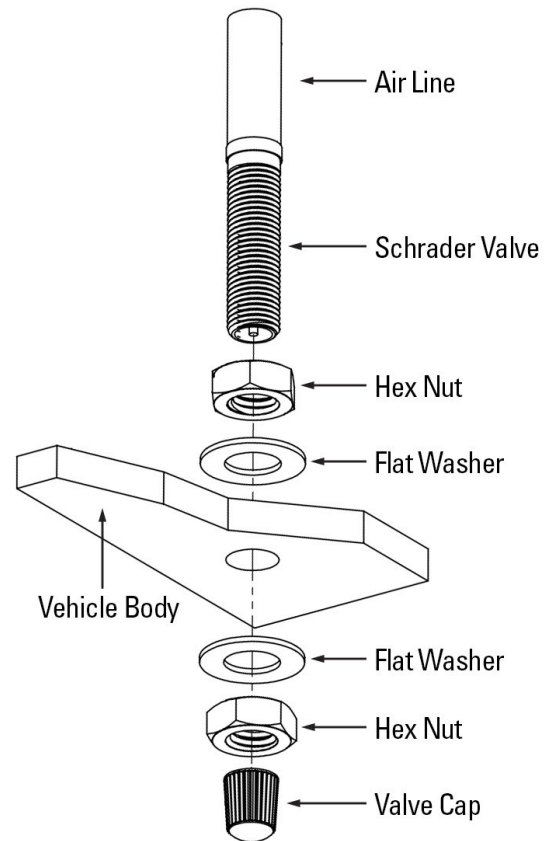

13



14

Thank you again, and congratulations on the installation of the air suspension kit.

OPTIONAL ACCESSORIES

Optional dual needle air gauges are available to monitor pressure in each spring from vehicle cab, as well as a full line of air compressors, air tanks, and solenoids built to work with and control your air spring system.

OPERATING YOUR VEHICLE WITH AIR SUSPENSION

Air springs have minimum and maximum pressure requirements. Never operate your vehicle with less than 10 psi in air spring and never inflate air springs over 100 psi. Damage to air springs will result.

Check air pressure in air springs daily for first couple of days to ensure a leak has not developed. Air springs are designed to maintain the vehicles stock ride height with a load. Do not use the air springs as a means to lift vehicle with no load. This will result in a harsh ride.

SERVICING YOUR VEHICLE WITH AIR SUSPENSION

When lifting the vehicle with a floor jack or hoist on the frame, never allow the air spring to limit the travel of the axle. Try to always jack the vehicle on the axle. Suspending the axle with the air spring limiting the axle travel will damage the air spring and void the air spring warranty.

WARRANTY

The owner's warranty will be void if air springs are run with less than the minimum of 10 psi. See additional warranty for details.

