

Installation Manual



AIR SUSPENSION KIT

Toyota Tundra (2WD/4WD)*

Use the most advanced air springs on the market to eliminate your vehicle's sag, sway and bottoming out. This heavy duty air suspension kit levels your truck's stance while providing added support for an overall smooth and safe ride.

* See application guide for proper fitment.

L6611_REV1_02.20.2024_ECN 1-2880

Thank you and congratulations on the purchase of an Air Suspension kit. Please read the entire manual prior to starting the installation to ensure you can complete it once started.

IMPORTANT

This air suspension kit will not increase the GVWR (*Gross Vehicle Weight Rating*), as the GVWR is determined by the vehicle manufacturer. **Do not exceed the maximum capacity listed by the vehicle manufacturer.**

For safe and proper operation of the vehicle, never exceed a maximum of 100PSI in the air springs. Staying under the pressure limit will ensure maximum air spring life. **Failure in doing so may result in damage to your vehicle and/or a void warranty.**

SAFETY WARNINGS!

! Please read and abide the instructions found in this manual, paying close attention to the helpful, cautionary or dangerous warning icons highlighting important safety recommendations and maintenance suggestions throughout this manual.

+ **HELPFUL INSTALL TIP**
Additional information that could potentially make the job a little easier.

! **PLEASE USE CAUTION**
Unsafe practices could result in damage to you or your vehicle, or others.

! **DANGER WARNING**
Hazards which could result in severe personal injury or death.

! Serious personal injury or death may result from an air spring failure or accident due to improper installation or air spring pressure operation or maintenance.

! Inflating an unsecured air spring is dangerous. If it bursts, it could be hurled into the air with explosive force resulting in serious personal injury or death. Never inflate an air spring unless it is secured to the vehicle.

! Removing and replacing air springs can be dangerous. This is only a job for a qualified service professional. Never perform air spring service procedures without proper training, tools, and equipment.

BEFORE STARTING THE INSTALLATION

- Ensure the application information is correct for the make, model and year of the vehicle you are installing the kit on.
 - Some vehicles are equipped with a rear wheel brake proportioning valve. Check with the manufacturer before installing the air spring kit, as it may affect braking performance.
 - It is recommended to use a good quality anti-seize on all fasteners. This will reduce the chance of corrosion on the fasteners and will help facilitate removal, if required at a later date.
- !** **PLEASE NOTE: This kit contains push-to-connect fittings; using scissors or wire cutters to cut the nylon air line will distort the line and cause the connection to leak. The air line must be cut off squarely with the hose cutter provided in this kit, or a sharp utility knife. Failure to do so may void the warranty.**

! **WARNING:** This product can expose you to the chemical Hexavalent Chromate, which is known to the State of California to cause cancer and birth defects or other reproductive harm. **For more information go to www.P65Warnings.ca.gov**

KIT CONTENTS

Please confirm the items below are provided in your kit before starting the installation. Reference the kit explosion diagram on the following page for part assembly.

HEAVY DUTY KITS		QTY	PART #
A*	Double Convoluted Spring	2	HP10000

HEAVY DUTY JOUNCE BUMPER KITS		QTY	PART #
A*	Double Convoluted Spring w/ Jounce Bumper	2	HP10000J

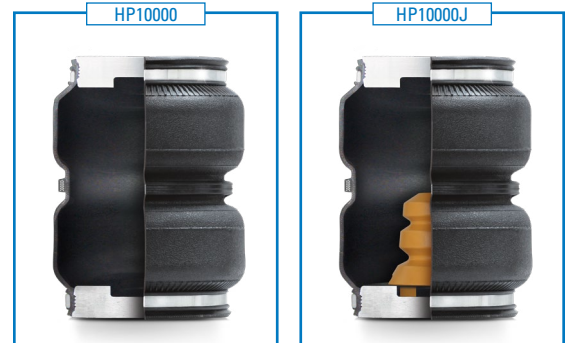

KIT CONTENTS		QTY	PART #
B	Roll Plate	4	HP10054
C	Bracket, Upper Frame - Driver Side	1	HP2015
D	Bracket, Upper Frame - Passenger Side	1	HP2016
E	Bracket, Upper Air Spring	2	HP2017
F	Bracket, Tundra Lower	2	HP2018
G	Axel Strap	2	HP2021
H	Screw, M8 - 1.25 x 25 Hex Head Cap	4	HP2023
I	Screw, M8 x 1.25 x 20 Flange Hex Head Cap	2	C3332
J	Bolt, 3/8" - 16 x 1.25" Carriage	4	HP1149
K	Bolt, 3/8" - 16 x 6" Carriage	4	HP1685
L	Screw, 3/8" - 24 x 3/4" Button Head Cap	8	HP1977
M	Nut, 3/8" - 16 Nylon Lock Flange	8	HP1975
N	Nut, M8 - 1.25 Nylon Lock	2	C11377
O	Washer, M8 Flat	2	C10473
P	Fitting, 1/4" NPT Brass Straight	2	HP1099

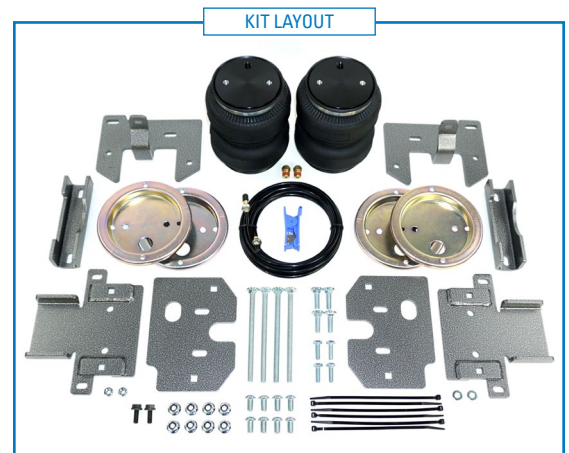

REQUIRED TOOLS

- Hoist or Floor Jack
- Safety Stands
- Safety Glasses
- Torque Wrench
- Standard Combination Wrenches
- 7/32" Hex Allen Wrench
- Ratchet
- Metric & Standard Sockets
- Hose Cutter (included) or Sharp Utility Knife
- Pipe Thread Sealant
- Spray Bottle with Dish Soap/Water
- Air Compressor/Compressed Air Source (to test/fill air springs)

KIT EXPLOSION DIAGRAM

DRIVER SIDE ASSEMBLY SHOWN (Passenger side assembly is mirrored)

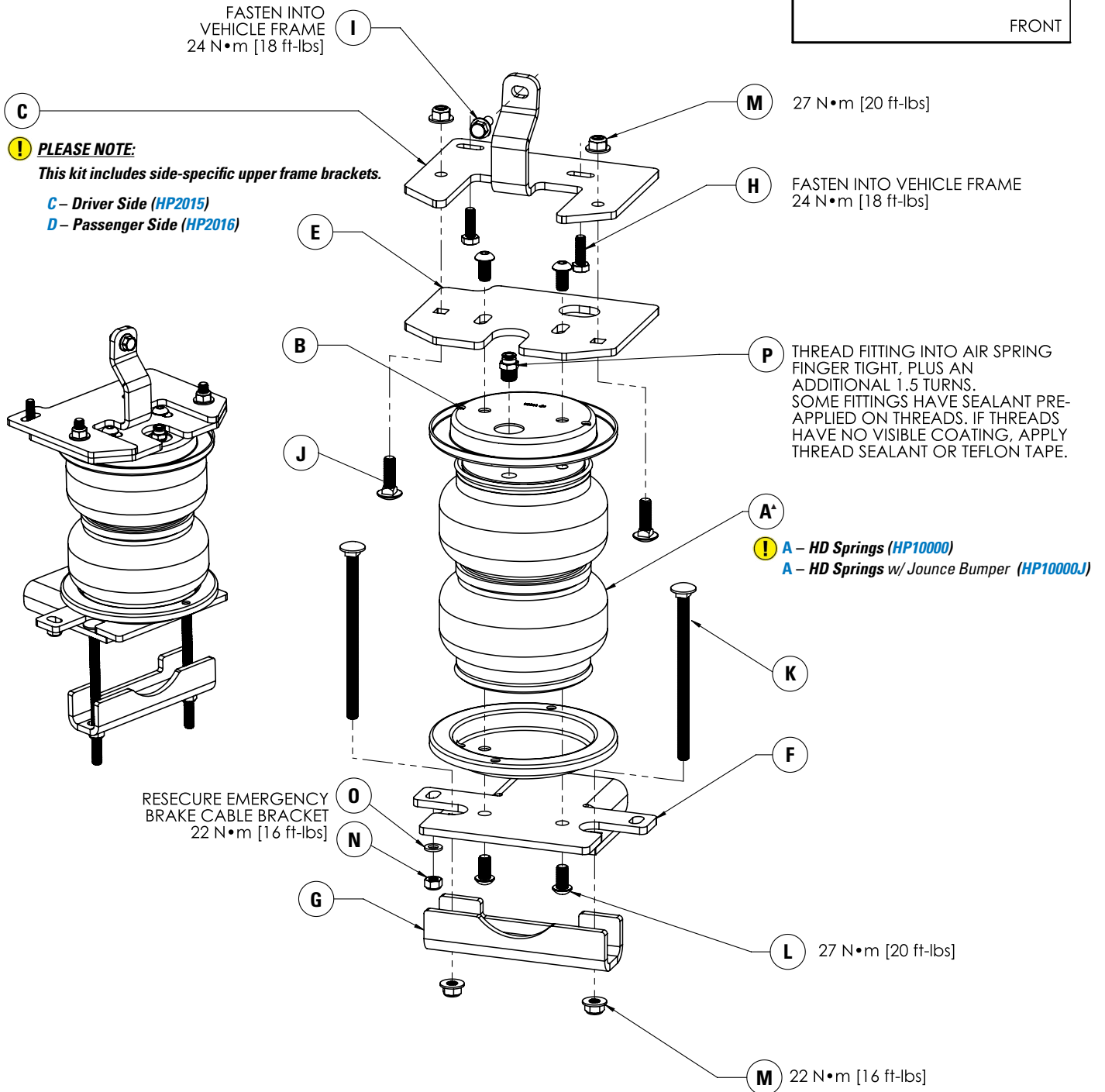
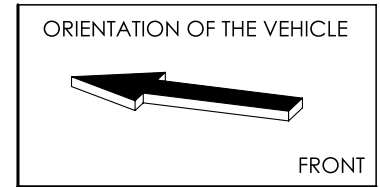

INSTALLATION INSTRUCTIONS

1 MEASURE STOCK RIDE HEIGHT & CLEARANCE

Park the vehicle on a level surface and remove any unnecessary weight from the vehicle to attain a "Normal Ride Height".

Using a measuring tape, measure the distance between the center of the wheel hub and the bottom of the fender well (see Figure 1 for reference) this will give you your stock Normal Ride Height.

Note the ride height for all four tires.

Check the clearance between the outside of the frame and the inside of the rear tires (as shown in red in Figure 1B), a minimum of 5" is required for adequate air spring clearance.

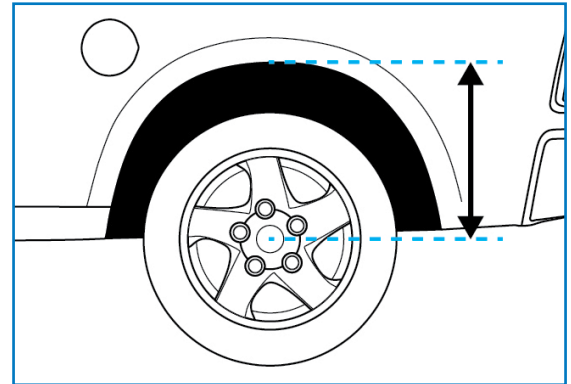

1A

2 REMOVE REAR WHEELS

+ **PLEASE NOTE:** This step is optional for this installation but will make the install easier to complete.

Place wheel chocks in front of and behind both front wheels.

Raise the rear of the truck high enough to remove both wheels and attain a comfortable working height.

Place two jack stands under rear axle (as shown in Figure 1B).

Lower the vehicle until the axle is supported by the jack stands.

Remove rear wheels.

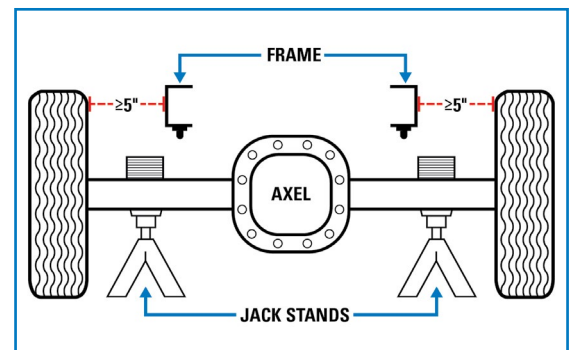

1B

3 REMOVE THE JOUNCE BUMPER

Remove the three hex head bolts securing the jounce bumper to the frame of the vehicle.

Two of the bolts are found on the underside of the frame (shown with white arrows in Figure 3A).

The third is on the outside of the frame (shown with a black arrow).

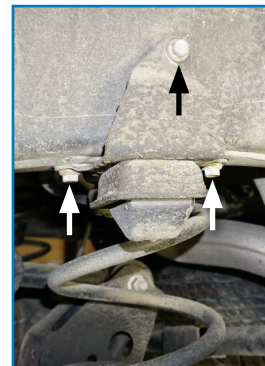

3A

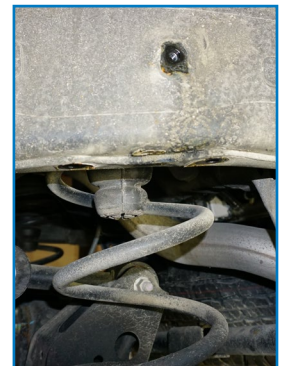

3B

4 DETACH E-BRAKE CABLE

Remove the factory bolt that secures the e-brake cable to the axle, but do not discard as it will be used in Step 11 for reassembly.



4

5 ATTACH UPPER BRACKET TO FRAME

! **PLEASE NOTE:** this kit includes *Driver Side (HP2015) & Passenger Side (HP2016) upper frame brackets*.

Confirm the correct upper frame bracket for the side of the vehicle you're installing on (using Figure 5A as a reference).

Attach the upper frame bracket to the outside frame of the vehicle by first threading an M8 flange hex head cap screw into the side of the frame (shown with a black arrow in Figure 5B), but do not fully tighten.

With the upper frame bracket hanging loose, position the bracket for the installation of the bottom two M8 hex head screws into the underside of the frame (shown with white arrows in Figure 5B).

Centre the upper frame bracket over the rear axle and torque down the bottom two hex head screws to 24 N•m (18 ft-lbs).

Then torque the first flange hex head cap screw to 24 N•m (18 ft-lbs).

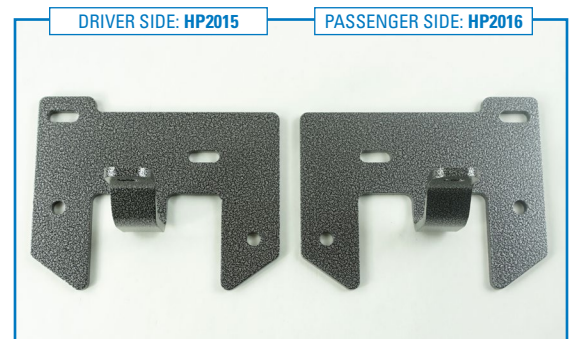

5A

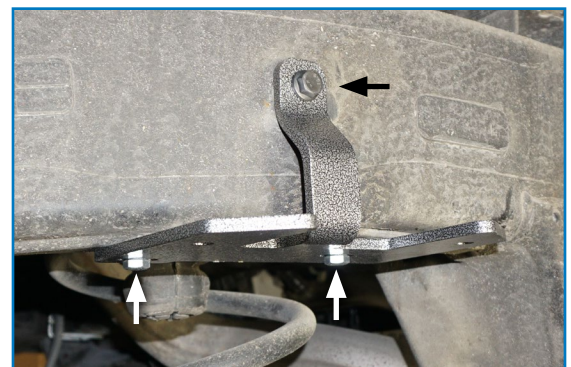

5B

6 LOWER BRACKET & BOTTOM AIR SPRING ASSEMBLY

Place a roll plate on the bottom side of the air spring, lining up the 2 smaller holes in the roll plate with the threaded holes on the bottom of the air spring.

+ *The bottom of the air spring is the side with only 2 holes.*

Insert the two long carriage bolts into lower bracket (as shown in Figure 6A with black arrows).

Install the lower bracket onto the bottom of the roll plate and air spring assembly using two 3/8" x 3/4" button head cap screws (shown with white arrows in Figure 6B).

Torque to 27 N•m (20 ft-lbs).

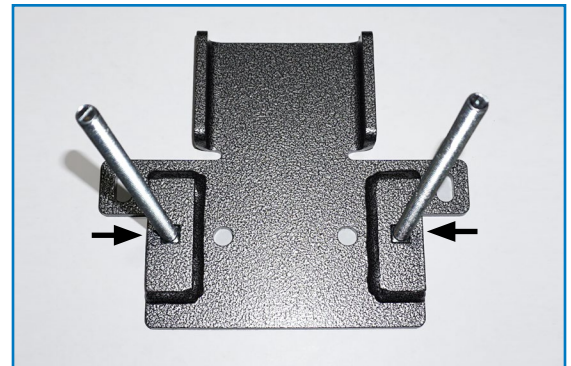

6A

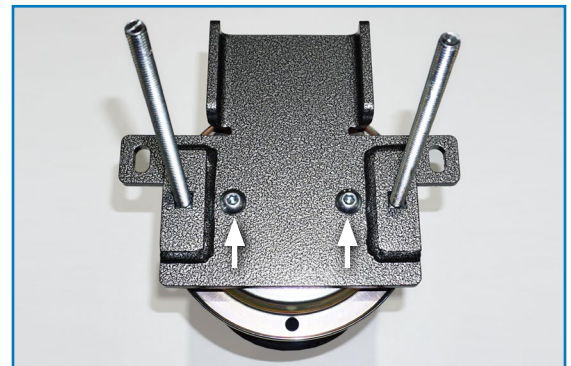

6B

7 TOP AIR SPRING ASSEMBLY

Flip over the assembly and place a second roll plate on top of the air spring, again lining up the 2 smaller holes with the 2 smaller threaded holes in the top of the air spring.

Install the NPT air fitting into the larger of the 3 holes in the top of the air spring (shown with a black arrow in Figure 7A).

+ *Some fittings have sealant pre-applied on the threads. If the threads have no visible coating, it is recommended to apply thread sealant or teflon tape (not included).*

Thread the fitting finger tight plus an additional 1.5 to 2 turns.

Install two of the shorter carriage bolts into the upper air spring bracket (as shown in Figure 7B with white arrows) before attaching the bracket to the air spring assembly.

Position the top bracket (reference Figure 7B for orientation), and install two 3/8" x 3/4" button head cap screws (as shown with the black arrows) in the slotted holes.

Torque to 27 N•m (20 ft-lbs).

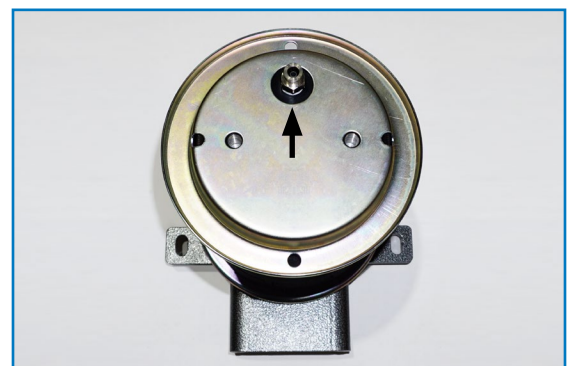

7A



7B

8 REPOSITION BRAKE LINES

Remove the original brake line retaining clip (shown with a white arrow in Figure 8A) and flip it around so that the brake line is held closer to the axle.

Insert the air spring assembly on top of the axle (as shown in Figure 8C).

If the brake lines are still making contact with the lower bracket carriage bolts (circled in Figure 8C), then make a small bend in the brake line to ensure it will not make contact with any air spring assembly components.

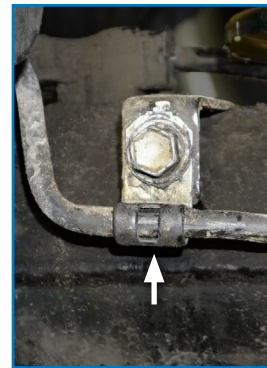

8A



8B

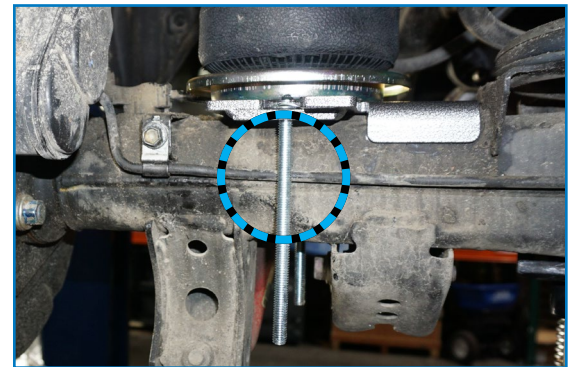

8C

9 AIR SPRING ASSEMBLY INSTALLATION

+ Installation of the air spring assembly is made easier by supporting the vehicle by the frame and allowing the axle to drop into the fully extended position.

With the air spring assembly still sitting on top of the axle, ensure the air spring is positioned correctly under the upper frame bracket so that the spring is correctly aligned (as shown in Figure 9A).

The upper air spring bracket can be adjusted by loosening the two 3/8" x 3/4" button head cap screws (previously installed in Step 7, shown with black arrows in Figure 7B) and sliding the bracket forward or backward in the slotted holes to achieve a proper air spring alignment.

Once aligned, torque both button head cap screws to 27 N•m (20 ft-lbs).

Install the locking flange nuts onto the shorter carriage bolts to secure the top bracket to the upper frame bracket (as shown in Figure 9B).

Torque to 42 N•m (31 ft-lbs).

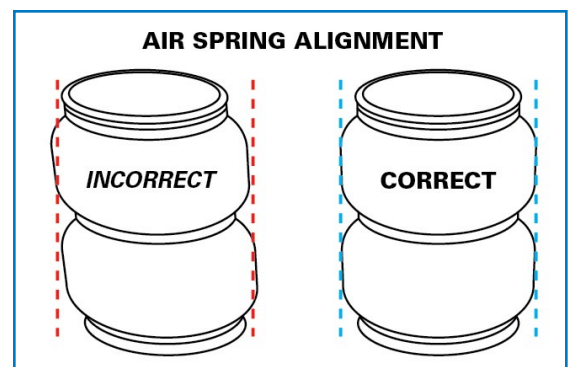

9A

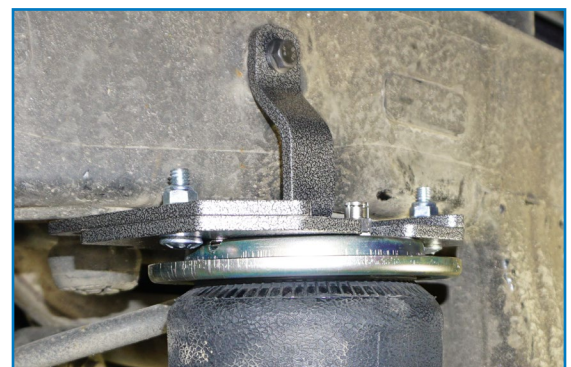

9B

10 INSTALL AXLE STRAP

Position the axle strap underneath the axle and pass the lower carriage bolts through the two slots.

Install the nylon flange nuts on to the carriage bolts (as shown in Figure 10) and tighten evenly.

When the axle strap and lower air spring bracket are snugged up to the axle, torque the axle strap nuts to 22 N•m (16 ft-lbs).

REPEAT STEPS 3-10 on the other side of the vehicle

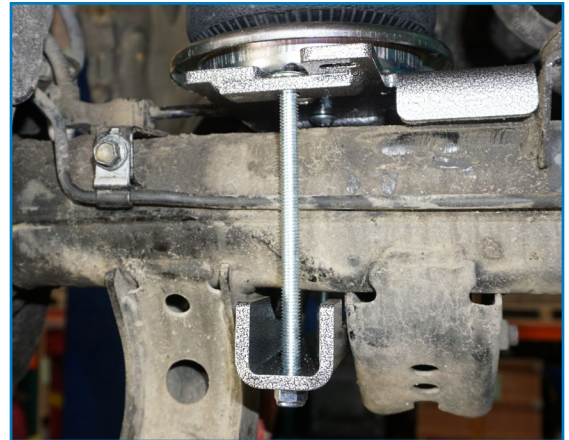

10

11 REINSTALL THE E-BRAKE CABLE

Reuse the OEM M8 bolt that was used to secure the e-brake cable to the axle, along with the M8 lock nut and washer provided in this kit.

Attach the brake cable to the tab found on the air spring assembly's lower bracket (as shown in Figure 11)

Installation continues on the following page.



11

INSTALL AIR LINE

Two fill valves are provided in this kit. The most common place to install them is in place of the license plate fasteners. Alternatively, two 5/16" holes can be drilled in a location of your choosing.

Cut the air line assembly into two equal lengths with the hose cutter provided in this kit or a sharp utility knife.

! **PLEASE NOTE:** *This kit contains push-to-connect fittings; using scissors or wire cutters to cut the nylon air line will distort the line and cause the connection to leak. The air line must be cut off squarely with a hose cutter or a sharp utility knife.*

Install one air line at a time starting at the fill valve location. Place a 5/16" nut on the air valve. Leave enough of the inflation valve in front of the nut to extend through the hole, install a flat washer, and 5/16" nut and cap (reference Figure A for assembly). There should be enough valve exposed after installation – approximately 1/2" – to easily apply a pressure gauge or an air chuck.

Route the air line back to the NPT fitting on the air spring, then cut the hose to length. Moisten the end of the air line prior to inserting it into the fitting and push it in until it stops.

Repeat with the other fill valve.

Secure the air lines using the provided tie-straps, away from any moving items and heat sources.

CHECK SYSTEM FOR LEAKS

Inflate both air springs to 90 psi and then use a mixture of dish soap and water on all air line connections to detect any air leaks. Large, expanding bubbles indicate a leak (as shown in Figure B).

Repair as necessary and retest.

Inflate air springs to a predetermined value and on following day recheck pressure. If one or both of air springs have lost pressure, an air leak is present.

! **Leak must be repaired, and then retested until no leaks exist.**

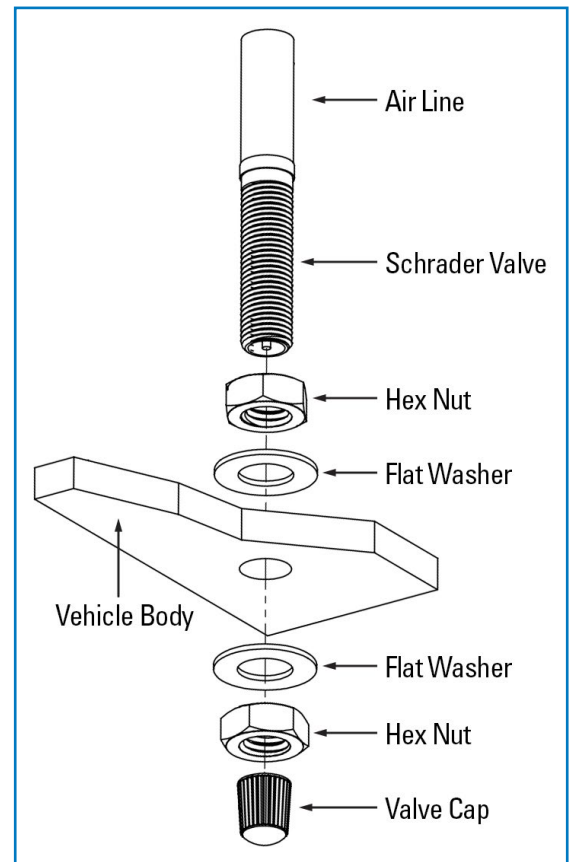

A

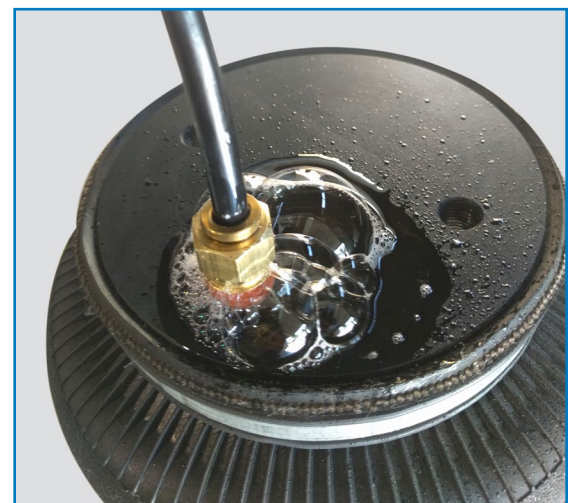

*Air Spring & NPT Air Fitting may differ between kits

B

CONGRATULATIONS! You have completed the install

After Installation continues on the following page.

.....

Thank you again, and congratulations on the installation of your Air Suspension kit.

AFTER COMPLETING THE INSTALLATION

- The air spring must have clearance between itself and the surrounding components to prevent any contact when spring is inflated or compressed. Trimming off excess bolt length may also be required to ensure no contact with the spring or other suspension components can be made once installed.
- If removed, re-install the wheels and torque fasteners to the manufacturer’s specifications. Re-torque all fasteners after the first 500 miles of driving.

OPERATING YOUR VEHICLE WITH AIR SUSPENSION

Air springs have minimum and maximum recommended pressure requirements:

PART #	SPRING STYLE	SPRING TYPE	MIN PSI	MAX PSI
HP10189	In-Coil	STANDARD DUTY	5 PSI	70 PSI
HP10560		STANDARD DUTY		
HP10001	Sleeve Style	STANDARD DUTY	10 PSI	100 PSI
HP10173		STANDARD DUTY		
HP10199		STANDARD DUTY		
HP10083	Single Convoluted	HEAVY DUTY	5 PSI	100 PSI
HP10083J		HEAVY DUTY with JOUNCE BUMPER	0 PSI* / 5 PSI	100 PSI
HP10000	Double Convoluted	HEAVY DUTY	5 PSI	100 PSI
HP10000J		HEAVY DUTY with JOUNCE BUMPER	0 PSI* / 5 PSI	100 PSI
HP10068	Large Double Convoluted	HEAVY DUTY	5 PSI	100 PSI
HP10438	Double Convoluted	EXTREME DUTY	5 PSI	100 PSI
HP10438J		EXTREME DUTY with JOUNCE BUMPER	0 PSI* / 5 PSI	100 PSI

** Springs with a jounce bumper can be run at zero PSI when vehicle is unloaded only*

For safe and proper operation, never operate the vehicle over the maximum listed PSI in the air springs. Staying under the pressure limit will ensure maximum air spring life. **Failure in doing so may result in damage to your vehicle and/or a void warranty.**

! It is recommended to check the air pressure in your air springs daily for first couple of days to ensure a leak has not developed.

Air springs are designed to maintain the vehicle’s stock ride height with a load. Do not use the air springs as a means to lift vehicle with no load. This will result in a harsh ride.

SERVICING YOUR VEHICLE WITH AIR SUSPENSION

When lifting the vehicle with a floor jack or hoist on the frame, never allow the air spring to limit the travel of the axle. Try to always jack the vehicle on the axle. Suspending the axle with the air spring limiting the axle travel will damage the air spring and void the air spring warranty.

WARRANTY

See additional warranty included with this kit for details.