

Installation Manual



AIR SUSPENSION KIT

Toyota Tundra (2WD/4WD)*

Use the most advanced air springs on the market to eliminate your vehicle's sag, sway and bottoming out. This heavy duty air suspension kit levels your truck's stance while providing added support for an overall smooth and safe ride.

* See application guide for proper fitment.

Thank you and congratulations on the purchase of an Air Suspension kit. Please read the entire manual prior to starting the installation to ensure you can complete it once started.

IMPORTANT

This air suspension kit will not increase the GVWR (*Gross Vehicle Weight Rating*), as the GVWR is determined by the vehicle manufacturer. **Do not exceed the maximum capacity listed by the vehicle manufacturer.**

For safe and proper operation of the vehicle, never exceed a maximum of 100PSI in the air springs. Staying under the pressure limit will ensure maximum air spring life. **Failure in doing so may result in damage to your vehicle and/or a void warranty.**

SAFETY WARNINGS!

! Please read and abide the instructions found in this manual, paying close attention to the helpful, cautionary or dangerous warning icons highlighting important safety recommendations and maintenance suggestions throughout this manual.

+ **HELPFUL INSTALL TIP**
Additional information that could potentially make the job a little easier.

! **PLEASE USE CAUTION**
Unsafe practices could result in damage to you or your vehicle, or others.

! **DANGER WARNING**
Hazards which could result in severe personal injury or death.

! Serious personal injury or death may result from an air spring failure or accident due to improper installation or air spring pressure operation or maintenance.

! Inflating an unsecured air spring is dangerous. If it bursts, it could be hurled into the air with explosive force resulting in serious personal injury or death. Never inflate an air spring unless it is secured to the vehicle.

! Removing and replacing air springs can be dangerous. This is only a job for a qualified service professional. Never perform air spring service procedures without proper training, tools, and equipment.

BEFORE STARTING THE INSTALLATION

PLEASE NOTE: This manual is used across multiple kit variations. The 2007-2021 kit is used as reference throughout most of the manual but the procedure remains the same across all part numbers (unless specifically noted in a step).

- Ensure the application information is correct for the make, model and year of the vehicle you are installing the kit on.
- Some vehicles are equipped with a rear wheel brake proportioning valve. Check with the manufacturer before installing the air spring kit, as it may affect braking performance.
- It is recommended to use a good quality anti-seize on all fasteners. This will reduce the chance of corrosion on the fasteners and will help facilitate removal, if required at a later date.

! **PLEASE NOTE:** This kit contains push-to-connect fittings; using scissors or wire cutters to cut the nylon air line will distort the line and cause the connection to leak. The air line must be cut off squarely with the hose cutter provided in this kit, or a sharp utility knife. **Failure to do so may void the warranty.**

! **WARNING:** This product can expose you to the chemical Hexavalent Chromate, which is known to the State of California to cause cancer and birth defects or other reproductive harm. **For more information go to www.P65Warnings.ca.gov**

! Please ensure you are installing the correct kit for your vehicle application before starting the installation.

- ▶ 2001-2006 Toyota Tundra (2WD/4WD) PAGE 3
- ▶ 2001-2006 Toyota Tundra (2WD/4WD) (with 1" Protruding Jounce Bumper Pad) PAGE 5
- ▶ 2007-2021 Toyota Tundra (2WD/4WD) PAGE 7

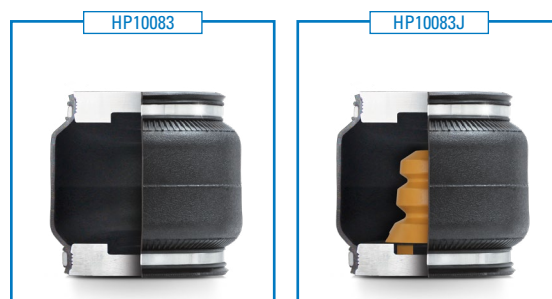

KIT CONTENTS

- ▶ 2001-2006 Toyota Tundra (2WD/4WD)

Please confirm the items below are provided in your kit before starting the installation. Reference the kit explosion diagram on the following page for part assembly.

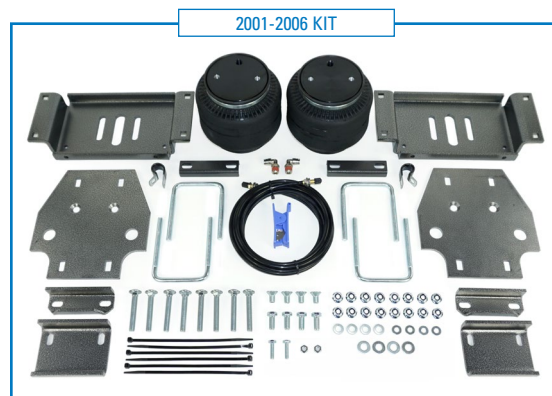

HEAVY DUTY KITS		QTY	PART #
A*	Single Convolved Spring	2	HP10083

HEAVY DUTY JOUNCE BUMPER KITS		QTY	PART #
A*	Single Convolved Spring w/ Jounce Bumper	2	HP10083J

REQUIRED TOOLS

- Hoist or Floor Jack
- Safety Stands
- Safety Glasses
- Torque Wrench
- Standard Combination Wrenches
- 7/32" Hex Allen Wrench
- Ratchet
- Metric & Standard Sockets
- Hose Cutter (included) or Sharp Utility Knife
- Pipe Thread Sealant
- Spray Bottle with Dish Soap/Water
- Air Compressor/Compressed Air Source (to test/fill air springs)

KIT CONTENTS		QTY	PART #
B	Bracket, Lower	2	HP0104
C	Bracket, Upper	2	HP0110
D	Bracket, Upper Clamp	2	HP0111
E	Bracket, Clamp	2	HP0112
F	Bracket, Spacer	2	HP0113
G	5/8" Adel Clamp	2	HP1006
H	U-Bolt, 3/8" - 16 x 4.25 x 3.5	4	HP2029
I	Screw, Hex Head Cap	2	C10448
J	Bolt, 3/8" - 24 x 3/4" Countersunk	4	HP1008
K	Bolt, 3/8" - 24 x 7/8" Hex Head	4	HP1002
L	Bolt, 3/8" - 16 x 2.5" Carriage	8	HP1005
M	Washer, 1/4" Flat	4	P02190
N	Washer, 3/8" Flat	4	C653
O	Washer, 3/8" Split Lock	4	C18007
P	Nut, 1/4" Nylon Lock	2	C11844
Q	Nut, 3/8" - 16 Nylon Lock Flange	16	HP1975
R	90° Swivel Fitting, 1/4" Hose to 1/4" NPT	2	HP1100
S	Air Line/Valve Assembly	1	HP1344
T	Tie Straps	6	C11618

KIT EXPLOSION DIAGRAM

2001-2006 DRIVER SIDE ASSEMBLY SHOWN

(Passenger side assembly is mirrored)

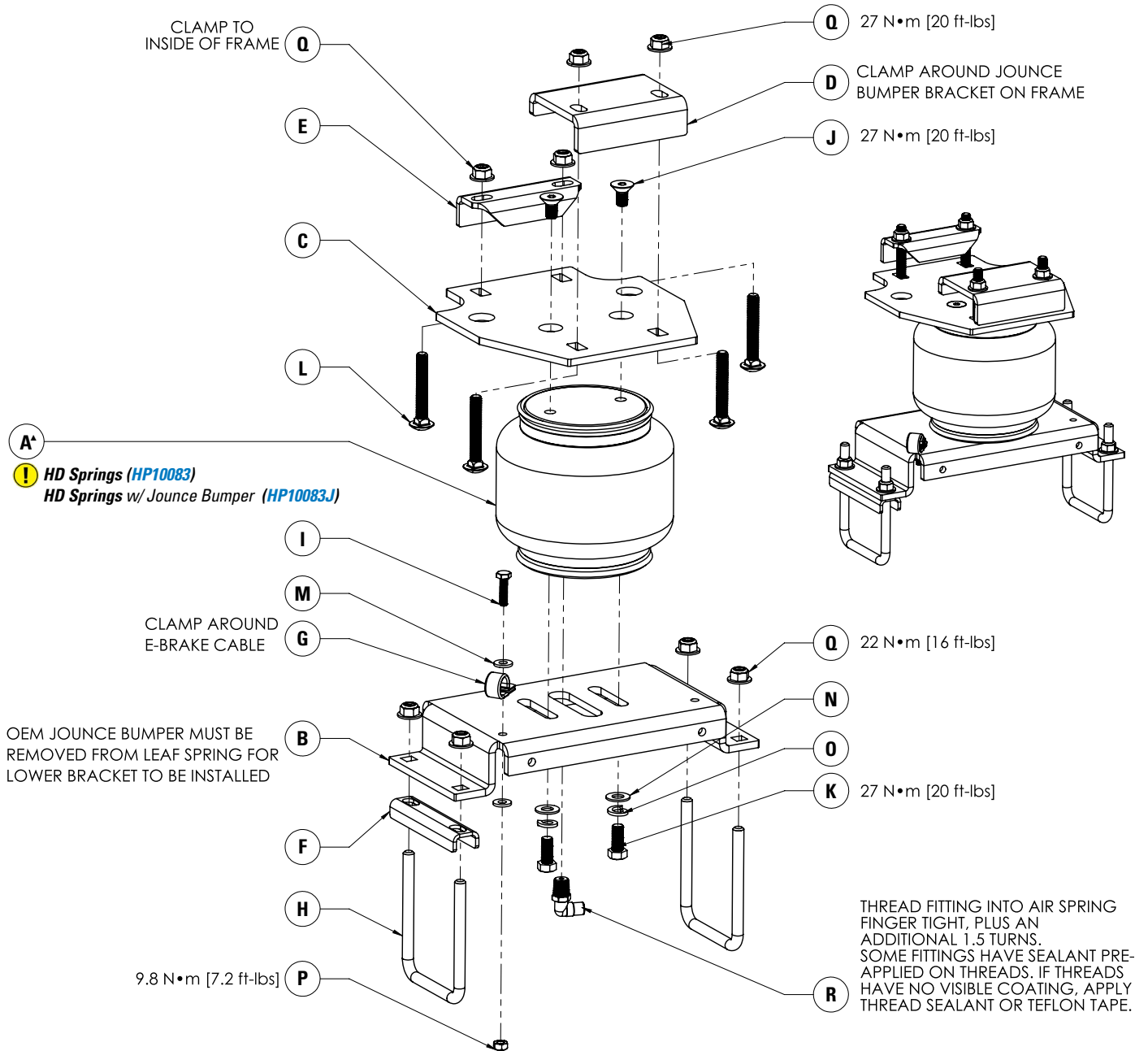

KIT CONTENTS

- ▶ 2001-2006 Toyota Tundra (2WD/4WD)
(with 1" Protruding Jounce Bumper Pad)

Please confirm the items below are provided in your kit before starting the installation. Reference the kit explosion diagram on the following page for part assembly.

HEAVY DUTY KITS		QTY	PART #
A*	Single Convoluted Spring	2	HP10083

HEAVY DUTY JOUNCE BUMPER KITS		QTY	PART #
A*	Single Convoluted Spring w/ Jounce Bumper	2	HP10083J

.....

KIT CONTENTS		QTY	PART #
B	Bracket, Lower	2	HP0104
C	Bracket, Upper	2	HP0110
D	Bracket, Rear Upper	2	HP0124
E	Bracket, Clamp	2	HP0112
F	Bracket, Spacer	2	HP0113
G	5/8" Adel Clamp	2	HP1006
H	U-Bolt, 3/8" - 16 x 4.25 x 3.5	4	HP2029
I	Screw, Hex Head Cap	2	C10448
J	Bolt, 3/8" - 24 x 3/4" Countersunk	4	HP1008
K	Bolt, 3/8" - 24 x 7/8" Hex Head	4	HP1002
L	Bolt, 3/8" - 16 x 2.5" Carriage	4	HP1005
M	Bolt, 3/8" - 16 x 3" Carriage	4	HP1003
N	Washer, 1/4" Flat	4	P02190
O	Washer, 3/8" Flat	4	C653
P	Washer, 3/8" Split Lock	4	C18007
Q	Nut, 1/4" Nylon Lock	2	C11844
R	Nut, 3/8" - 16 Nylon Lock Flange	16	HP1975
S	90° Swivel Fitting, 1/4" Hose to 1/4" NPT	2	HP1100
T	Air Line/Valve Assembly	1	HP1344
U	Tie Straps	6	C11618

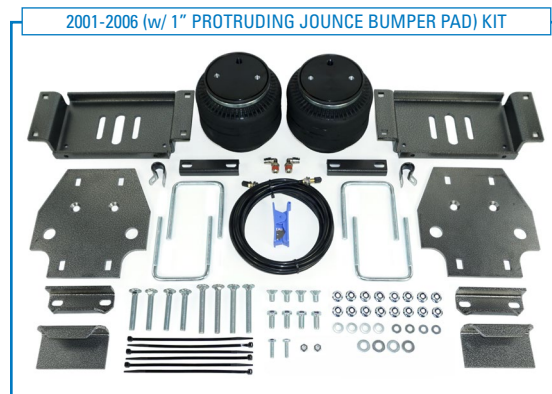
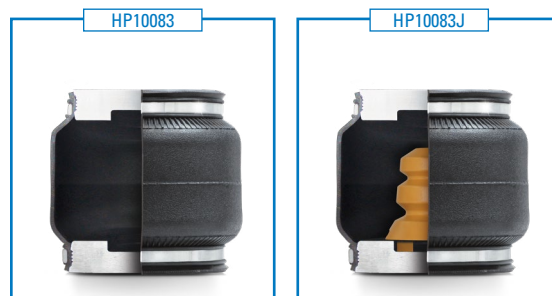

REQUIRED TOOLS

- Hoist or Floor Jack
- Safety Stands
- Safety Glasses
- Torque Wrench
- Standard Combination Wrenches
- 7/32" Hex Allen Wrench
- Ratchet
- Metric & Standard Sockets
- Hose Cutter (included) or Sharp Utility Knife
- Pipe Thread Sealant
- Spray Bottle with Dish Soap/Water
- Air Compressor/Compressed Air Source (to test/fill air springs)

KIT EXPLOSION DIAGRAM

2001-2006 (w/ 1" Protruding Jounce Bumper Pad) DRIVER SIDE ASSEMBLY SHOWN

(Passenger side assembly is mirrored)

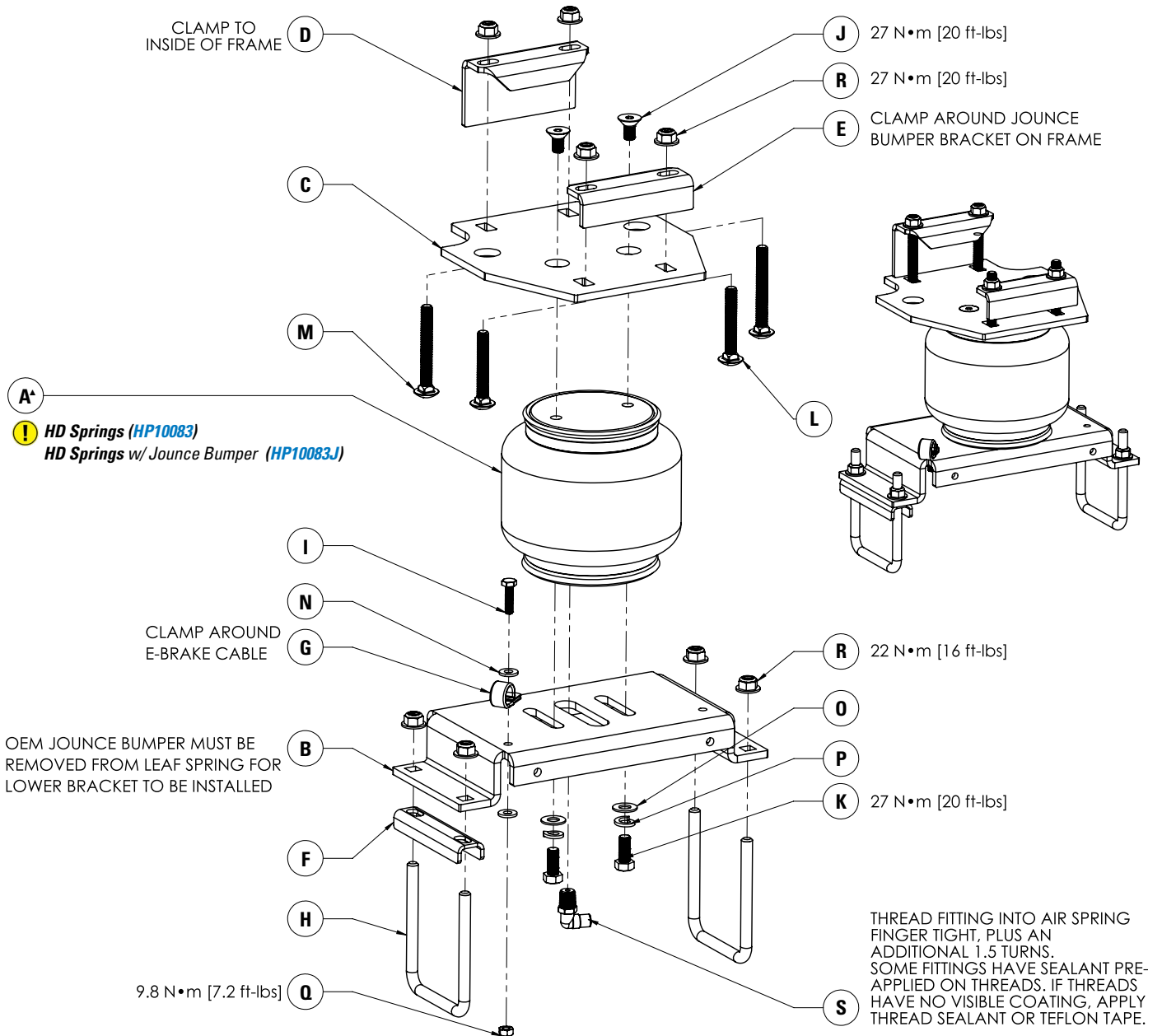

KIT CONTENTS

► 2007-2021 Toyota Tundra (2WD/4WD)

Please confirm the items below are provided in your kit before starting the installation. Reference the kit explosion diagram on the following page for part assembly.

HEAVY DUTY KITS		QTY	PART #
A*	Single Convoluted Spring	2	HP10083

HEAVY DUTY JOUNCE BUMPER KITS		QTY	PART #
A*	Single Convoluted Spring w/ Jounce Bumper	2	HP10083J



KIT CONTENTS		QTY	PART #
B	Bracket, Lower	2	HP0104
C	Bracket, Upper	2	HP0110
D	Bracket, Rear Upper	2	HP0124
E	Bracket, Clamp	2	HP0112
F	Bracket, Spacer	2	HP0113
G	5/8" Adel Clamp	2	HP1006
H	U-Bolt, 3/8" - 16 x 4.25 x 3.5	4	HP2029
I	Screw, Hex Head Cap	2	C10448
J	Bolt, 3/8" - 24 x 3/4" Countersunk	4	HP1008
K	Bolt, 3/8" - 24 x 7/8" Hex Head	4	HP1002
L	Bolt, 3/8" - 16 x 2.5" Carriage	4	HP1005
M	Bolt, 3/8" - 16 x 3" Carriage	4	HP1003
N	Washer, 1/4" Flat	4	P02190
O	Washer, 3/8" Flat	4	C653
P	Washer, 3/8" Split Lock	4	C18007
Q	Nut, 1/4" Nylon Lock	2	C11844
R	Nut, 3/8" - 16 Nylon Lock Flange	16	HP1975
S	90° Swivel Fitting, 1/4" Hose to 1/4" NPT	2	HP1100
T	Air Line/Valve Assembly	1	HP1344
U	Tie Straps	6	C11618

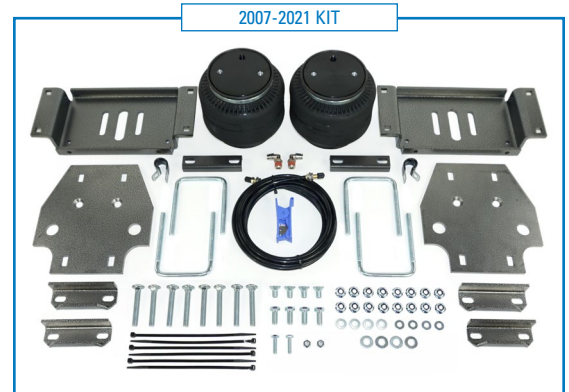

REQUIRED TOOLS

- Hoist or Floor Jack
- Safety Stands
- Safety Glasses
- Torque Wrench
- Standard Combination Wrenches
- 7/32" Hex Allen Wrench
- Ratchet
- Metric & Standard Sockets
- Hose Cutter (included) or Sharp Utility Knife
- Pipe Thread Sealant
- Spray Bottle with Dish Soap/Water
- Air Compressor/Compressed Air Source (to test/fill air springs)

KIT EXPLOSION DIAGRAM

2007-2021 DRIVER SIDE ASSEMBLY SHOWN

(Passenger side assembly is mirrored)

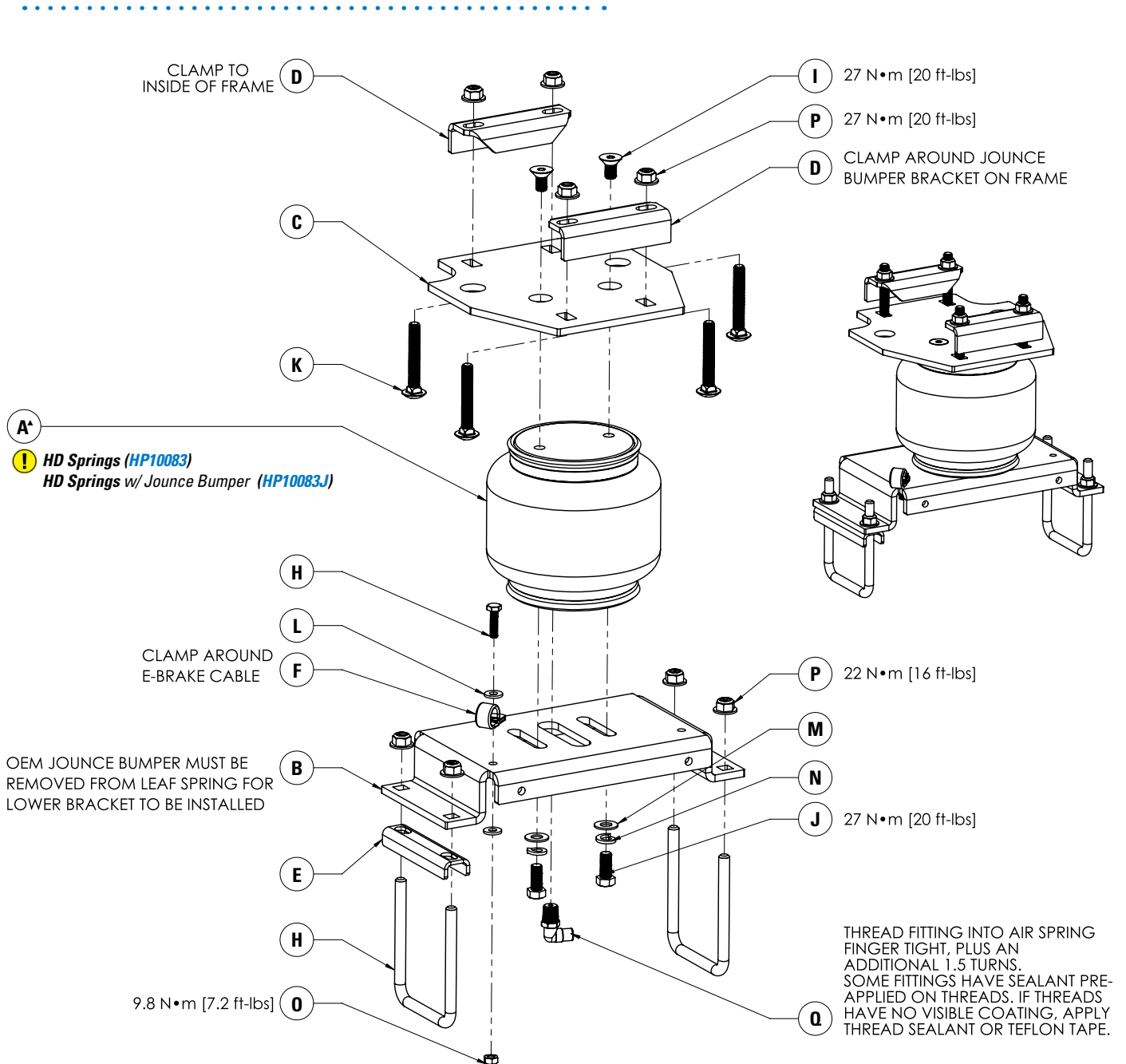

INSTALLATION INSTRUCTIONS

1 MEASURE STOCK RIDE HEIGHT & CLEARANCE

Park the vehicle on a level surface and remove any unnecessary weight from the vehicle to attain a "Normal Ride Height".

Using a measuring tape, measure the distance between the center of the wheel hub and the bottom of the fender well (see Figure 1 for reference) this will give you your stock Normal Ride Height.

Note the ride height for all four tires.

Check the clearance between the outside of the frame and the inside of the rear tires (as shown in red in Figure 1B), a minimum of 5" is required for adequate air spring clearance.

2 REMOVE REAR WHEELS

Place wheel chocks in front of and behind both front wheels.

Raise the rear of the truck high enough to remove both wheels and attain a comfortable working height.

Place two jack stands under rear axle (as shown in Figure 1B).

Lower the vehicle until the axle is supported by the jack stands and then remove the rear wheels.

3 REMOVE THE JOUNCE BUMPER

Using a sawzall or hacksaw, remove the jounce bumper by cutting the rubber portion off (as shown in the Figures 3A & 3B).

- ⚠ **PLEASE NOTE:** It is permissible to remove the jounce bumper by loosening the axle U-bolts and slipping the jounce bumper assembly out from underneath the U-bolts. **HOWEVER**, take precaution if you follow this method of removal, as the axle can shift from its factory mounting point to the leaf springs.

4 DETACH E-BRAKE

Remove the factory emergency brake cable support bracket in order to obtain clearance for the lower bracket.

- ⊕ A supplied support for the emergency brake cable will be installed in Step 14.

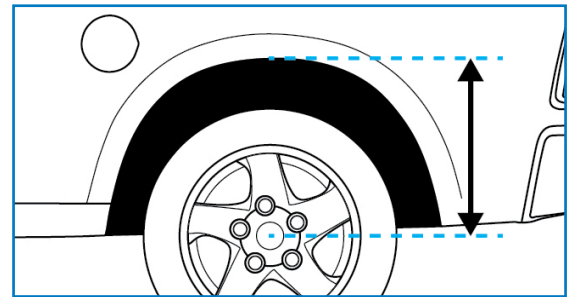

1A

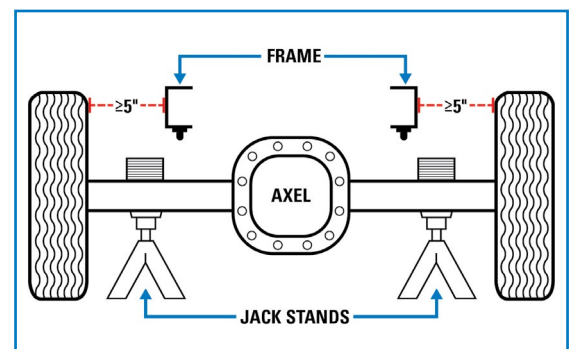

1B

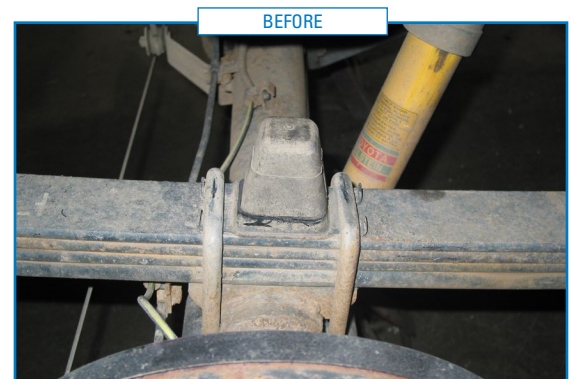

3A

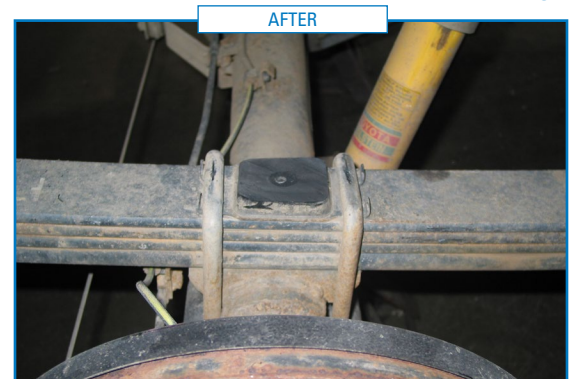

3B

5 INSTALL AIR FITTING

Locate the 90° swivel fittings and air springs provided, apply thread sealant to the threads, install the fitting into the port of the air spring (as shown with an arrow in Figure 5).

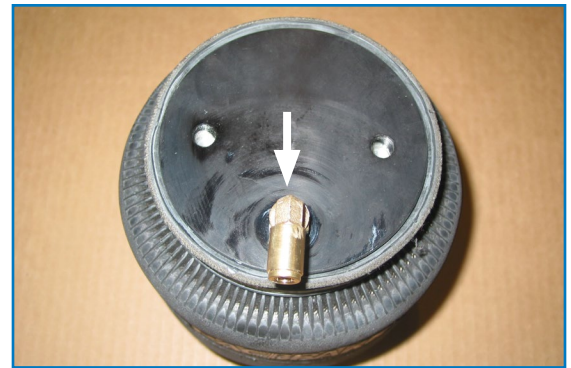

5

6 LOWER BRACKET ASSEMBLY

Place the air spring in front of you with the air fitting set on the opposite side of you pointing upwards (as seen in Figure 6).

Place the lower bracket over the fitting with the bent flanges facing upwards and towards you (see Figure 6 as reference).

Loosely install two 3/8" x 24 x 7/8" hex head bolts with lock and flat washers provided through the lower bracket into the two threaded holes of the air spring.

Do not tighten the two capscrews as adjustment will be required later in the installation.

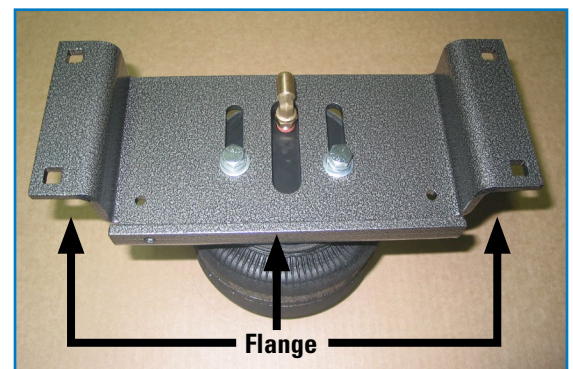

6

7 UPPER BRACKET ASSEMBLY

Turn the air spring & lower bracket assembly over. The bent flange of the lower bracket must be facing towards you.

Place the upper mounting bracket on top of the air spring, with countersunk holes facing up and the angled sides towards you (as seen in Figure 7).

Using two 3/8" - 24 x 7/8" countersunk hex head bolts provided, torque to 27 N•m (20 ft-lbs).

Attach the upper bracket to the air spring assembly and tighten the countersink hex head bolts securely.

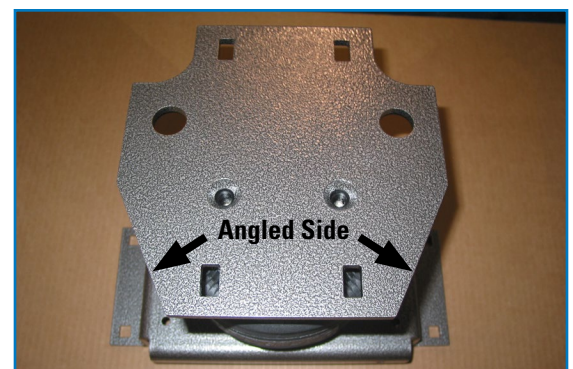

7

REPEAT STEPS 5-7 on the other air spring

8 INSTALL AIR SPRING ASSEMBLY

Ensure the lower air spring bracket is parallel to the frame flange directly above the upper air spring bracket.

2001-2006 TRUCK KITS ONLY Lower bracket spacers are provided to shim the lower bracket if necessary, the spacers are installed with the legs against the leaf springs.

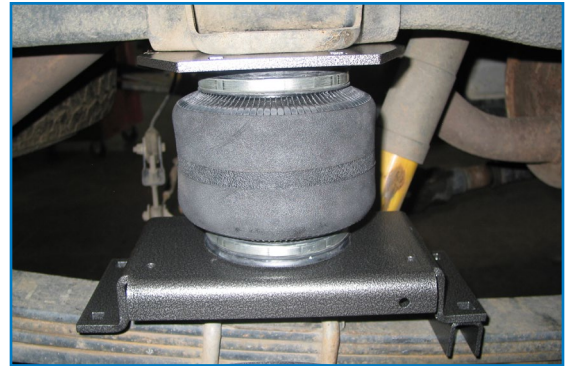

8

9 INSTALL U-BOLTS

Loosely install the U-bolts around the leaf spring and up through the lower air spring mounting bracket holes and spacers (if used).

Install the 3/8" nyloc flange nuts provided on the U-bolts.

10 DETERMINE THE CORRECT UPPER CLAMPS

⚠ PLEASE NOTE:

The difference between kits is the upper bracket clamp(s) - and longer carriage bolts for trucks with Jounce Bumpers 1" below frame. Use the Assembly Diagrams & Part Callouts below to determine the correct inner & outer brackets to use for your application.

2001-2006 TRUCK KITS (Figure 10A)

- ▶ Outer Clamps: HP0111
- ▶ Inner Clamps: HP0112

2007-2021 TRUCK KITS (Figure 10B)

- ▶ Outer Clamps: HP0112
- ▶ Inner Clamps: HP0112

2001-2006 TRUCKS W/ JOUNCE BUMPER 1" BELOW FRAME (Figure 10C)

- ▶ Outer Clamps: HP0112
- ▶ Inner Clamps: HP0124
- ▶ +3" Carriage Bolts: HP1003

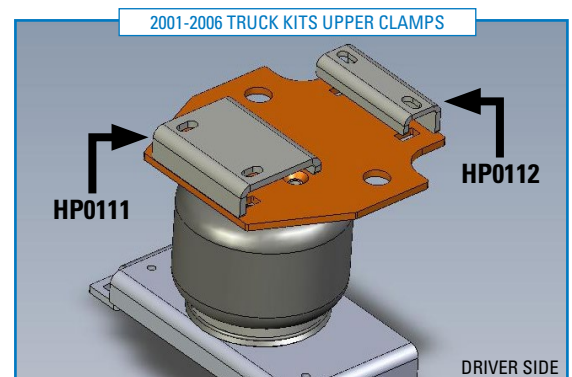

10A

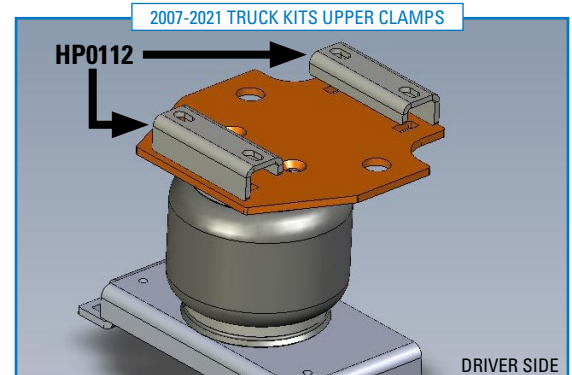

10B

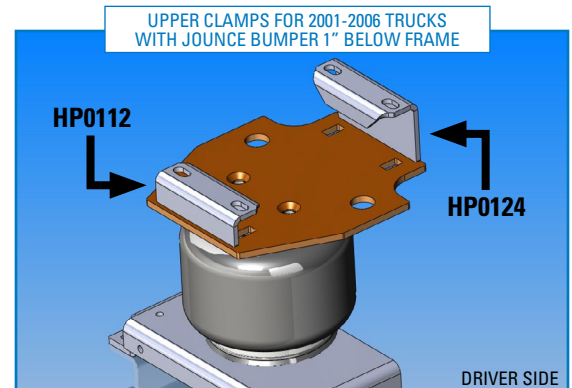

10C

11 INSTALL UPPER CLAMPS

! Use the information from the previous step to determine the correct upper clamps for your vehicles application

Loosely install the upper outer clamp bracket onto the upper air spring bracket installing two 3/8" x 2.5" carriage bolts up from the bottom (see Figure 11A), using the nyloc flange nuts provided.

The shorter leg of the clamp must be installed towards the frame.

Repeat for the upper inner clamp (Figure 11B)

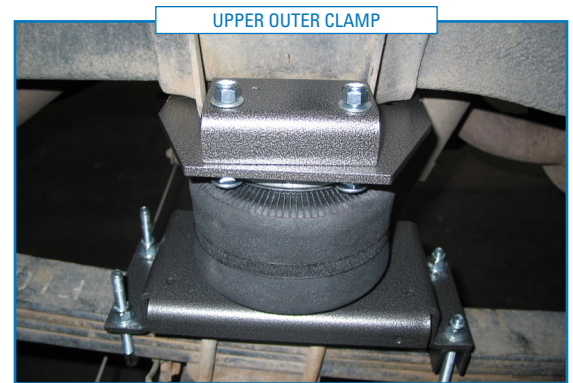

11A

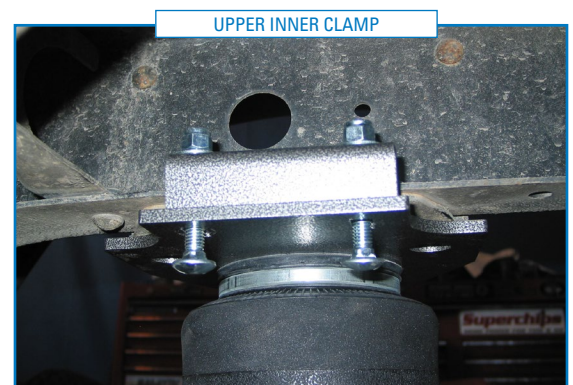

11B

12 UPPER AIR SPRING BRACKET CLAMP ALIGNMENT

The upper air spring bracket clamps must be positioned with one leg on the frame and the other leg squarely on top of the upper bracket (see Figure 12 for reference).

Once this alignment is complete, torque the 2 inner and 2 outer clamp carriage bolts to 27 N•m (20 ft-lbs).

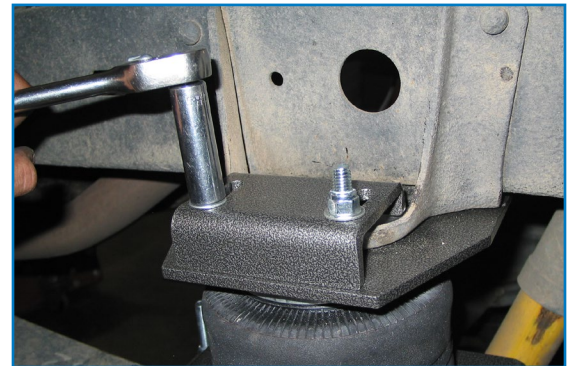

12

13 AIR SPRING ASSEMBLY ALIGNMENT

Position the lower air spring mounting bracket on the leaf spring.

Align the lower end of the air spring to the top by moving the lower air spring bracket to the front or rear of the leaf spring to achieve correct air spring alignment (see Figure 13A for reference).

Once the alignment is correct, torque the 4 U-bolt nyloc flange nuts evenly to 22 N•m (16 ft-lbs) (see Figure 13B).

Then align the lower end of the air spring to the top by sliding the lower end in or out on the elongated holes in the lower bracket.

Once alignment is correct, torque the lower air spring to bracket capscrews to 27 N•m (20 ft-lbs) (see Figure 13C).

(Optional) Cut off the threaded portion of the U-bolts above the nyloc flange nuts.

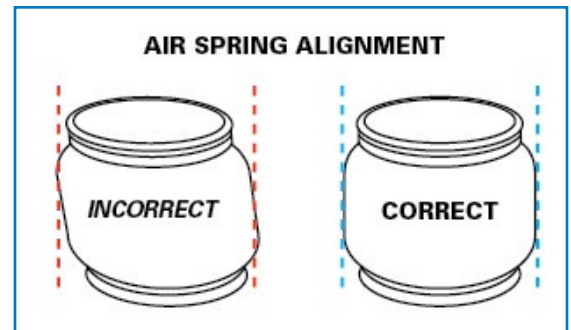

13A

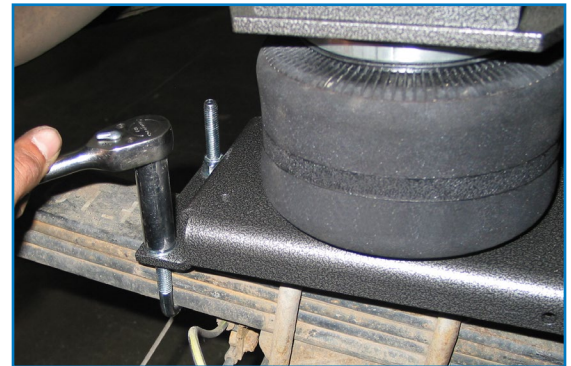

13B

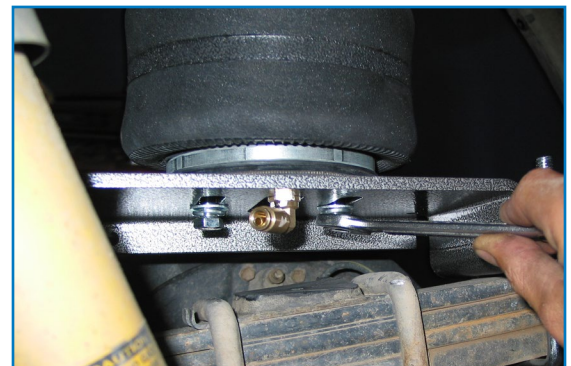

13C

14 REATTACH E-BRAKE

Install the Adel clamp provided around the emergency brake cable, using the hexhead capscrew, flat washers and nyloc nuts provided.

Fasten the Adel clamp to the forward hole in the top of the lower bracket (as shown in Figure 14 on the following page).

REPEAT STEPS 8-14 on the other air spring



14

INSTALL AIR LINE

Two fill valves are provided in this kit. The most common place to install them is in place of the license plate fasteners. Alternatively, two 5/16" holes can be drilled in a location of your choosing.

Cut the air line assembly into two equal lengths with the hose cutter provided in this kit or a sharp utility knife.

! **PLEASE NOTE:** *This kit contains push-to-connect fittings; using scissors or wire cutters to cut the nylon air line will distort the line and cause the connection to leak. The air line must be cut off squarely with a hose cutter or a sharp utility knife.*

Install one air line at a time starting at the fill valve location. Place a 5/16" nut on the air valve. Leave enough of the inflation valve in front of the nut to extend through the hole, install a flat washer, and 5/16" nut and cap (reference Figure A for assembly). There should be enough valve exposed after installation – approximately 1/2" – to easily apply a pressure gauge or an air chuck.

Route the air line back to the NPT fitting on the air spring, then cut the hose to length. Moisten the end of the air line prior to inserting it into the fitting and push it in until it stops.

Repeat with the other fill valve.

Secure the air lines using the provided tie-straps, away from any moving items and heat sources.

CHECK SYSTEM FOR LEAKS

Inflate both air springs to 90 psi (60 psi for in-coil bags), then use a mixture of dish soap and water on all air line connections to detect any air leaks. Large, expanding bubbles indicate a leak (as shown in Figure B).

Repair as necessary and retest.

Inflate air springs to a predetermined value and on following day recheck pressure. If one or both of air springs have lost pressure, an air leak is present.

! **Leak must be repaired, and then retested until no leaks exist.**

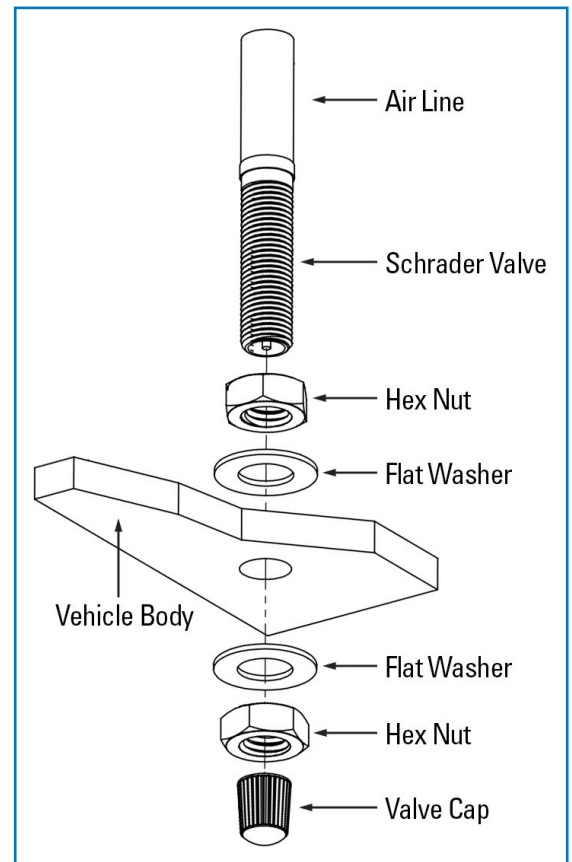

A

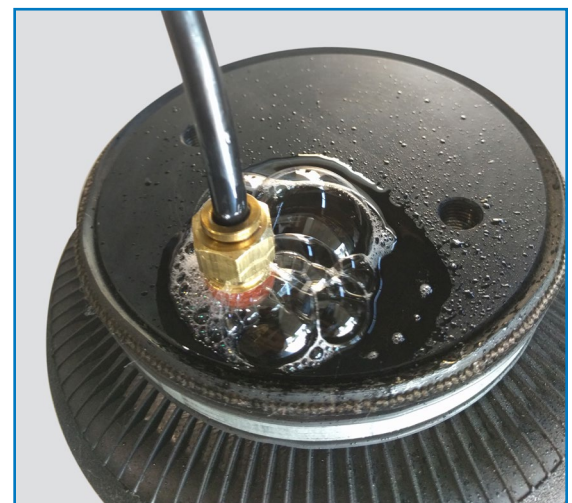

*Air Spring & NPT Air Fitting may differ between kits

B

CONGRATULATIONS! You have completed the install

After Installation continues on the following page.

Thank you again, and congratulations on the installation of your Air Suspension kit.

AFTER COMPLETING THE INSTALLATION

- The air spring must have clearance between itself and the surrounding components to prevent any contact when spring is inflated or compressed. Trimming off excess bolt length may also be required to ensure no contact with the spring or other suspension components can be made once installed.
- If removed, re-install the wheels and torque fasteners to the manufacturer’s specifications. Re-torque all fasteners after the first 500 miles of driving.

OPERATING YOUR VEHICLE WITH AIR SUSPENSION

Air springs have minimum and maximum recommended pressure requirements:

PART #	SPRING STYLE	SPRING TYPE	MIN PSI	MAX PSI
HP10189	In-Coil	STANDARD DUTY	5 PSI	70 PSI
HP10560		STANDARD DUTY		
HP10001	Sleeve Style	STANDARD DUTY	10 PSI	100 PSI
HP10173		STANDARD DUTY		
HP10199		STANDARD DUTY		
HP10083	Single Convoluted	HEAVY DUTY	5 PSI	100 PSI
HP10083J		HEAVY DUTY with JOUNCE BUMPER	0 PSI* / 5 PSI	100 PSI
HP10000	Double Convoluted	HEAVY DUTY	5 PSI	100 PSI
HP10000J		HEAVY DUTY with JOUNCE BUMPER	0 PSI* / 5 PSI	100 PSI
HP10068	Large Double Convoluted	HEAVY DUTY	5 PSI	100 PSI
HP10438	Double Convoluted	EXTREME DUTY	5 PSI	100 PSI
HP10438J		EXTREME DUTY with JOUNCE BUMPER	0 PSI* / 5 PSI	100 PSI

** Springs with a jounce bumper can be run at zero PSI when vehicle is unloaded only*

For safe and proper operation, never operate the vehicle over the maximum listed PSI in the air springs. Staying under the pressure limit will ensure maximum air spring life. **Failure in doing so may result in damage to your vehicle and/or a void warranty.**

! It is recommended to check the air pressure in your air springs daily for first couple of days to ensure a leak has not developed.

Air springs are designed to maintain the vehicle’s stock ride height with a load. Do not use the air springs as a means to lift vehicle with no load. This will result in a harsh ride.

SERVICING YOUR VEHICLE WITH AIR SUSPENSION

When lifting the vehicle with a floor jack or hoist on the frame, never allow the air spring to limit the travel of the axle. Try to always jack the vehicle on the axle. Suspending the axle with the air spring limiting the axle travel will damage the air spring and void the air spring warranty.

WARRANTY

See additional warranty included with this kit for details.