

Installation Manual



10594 KIT

Dodge RAM 2500/3500 6.7L Cummins Engines
with 1"-16 UN Oil Filter Threads*

*Oil filtration relocation kits provide easy access & serviceability
to the engine's oil filter.*

* See application guide for proper fitment.

Thank you and congratulations on the purchase of an Oil Filter Relocation Kit. Please read the entire manual prior to starting the installation to ensure you can complete it once started.

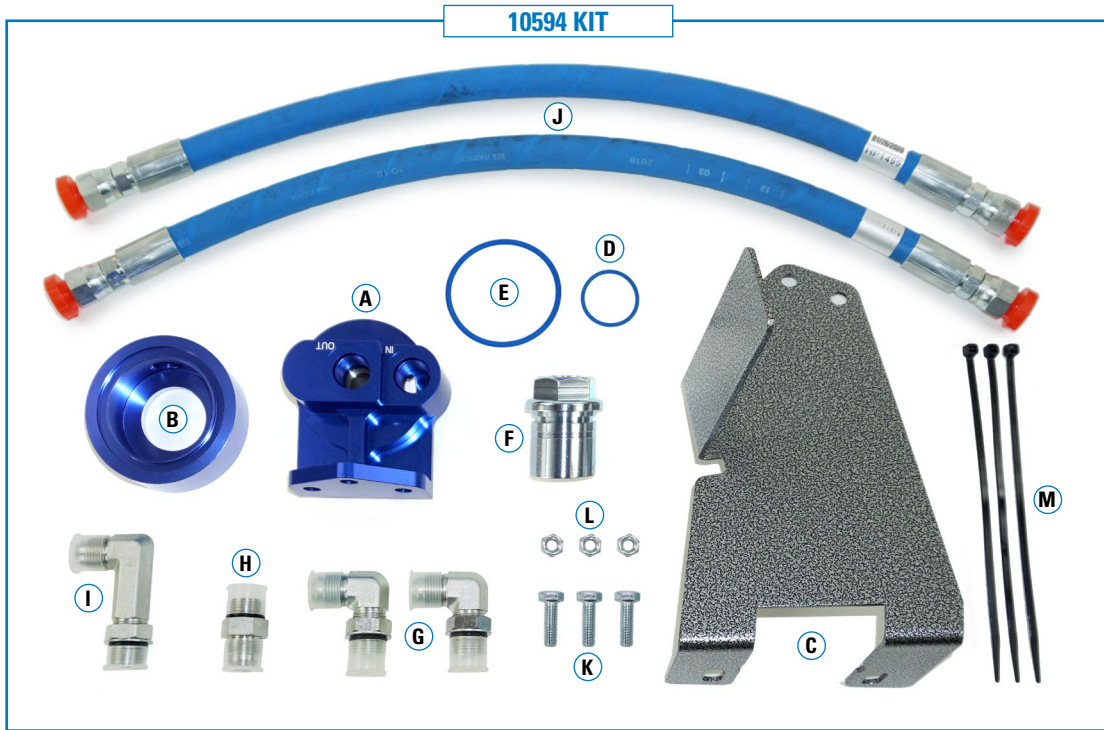

KIT CONTENTS

Please make sure all the items listed below are provided in your kit before starting the installation.

! A replacement oil filter is NOT included in this kit. Kits are designed to work with factory part number filters.

KIT CONTENTS	QTY	PART #
A Remote Filter Head	1	HP0042
B Filter Head, Adapter	1	HP1974
C Bracket, Filter Relocation	1	HP1605
D O-Ring, -124	1	HP1972
E O-Ring, -230	1	HP1973
F Filter Nut, 1-16 UN	1	HP1968
G Fitting, 90° Straight Thread Elbow	2	HP1024
H Fitting, Straight Thread	1	HP1025
I Fitting, 90° Straight Thread Extra Long Elbow	1	HP1330
J Assembly, Hydraulic Hose	2	HP1499
K Bolt, 5/16" - 18 x 1" Hex Head	3	HP1028
L Nut, 5/16" Nylon Lock	3	C11943
M Zip Ties	3	C11618

REQUIRED TOOLS

- Hoist or Floor Jack
- Safety Stands
- Safety Glasses
- Torque Wrench
- Ratchet
- Standard Combination Wrenches
- Metric & Standard Sockets

KIT EXPLOSION DIAGRAM

Please make sure all the items highlighted below and in the kit contents on the previous page, are provided in your kit before starting the installation.

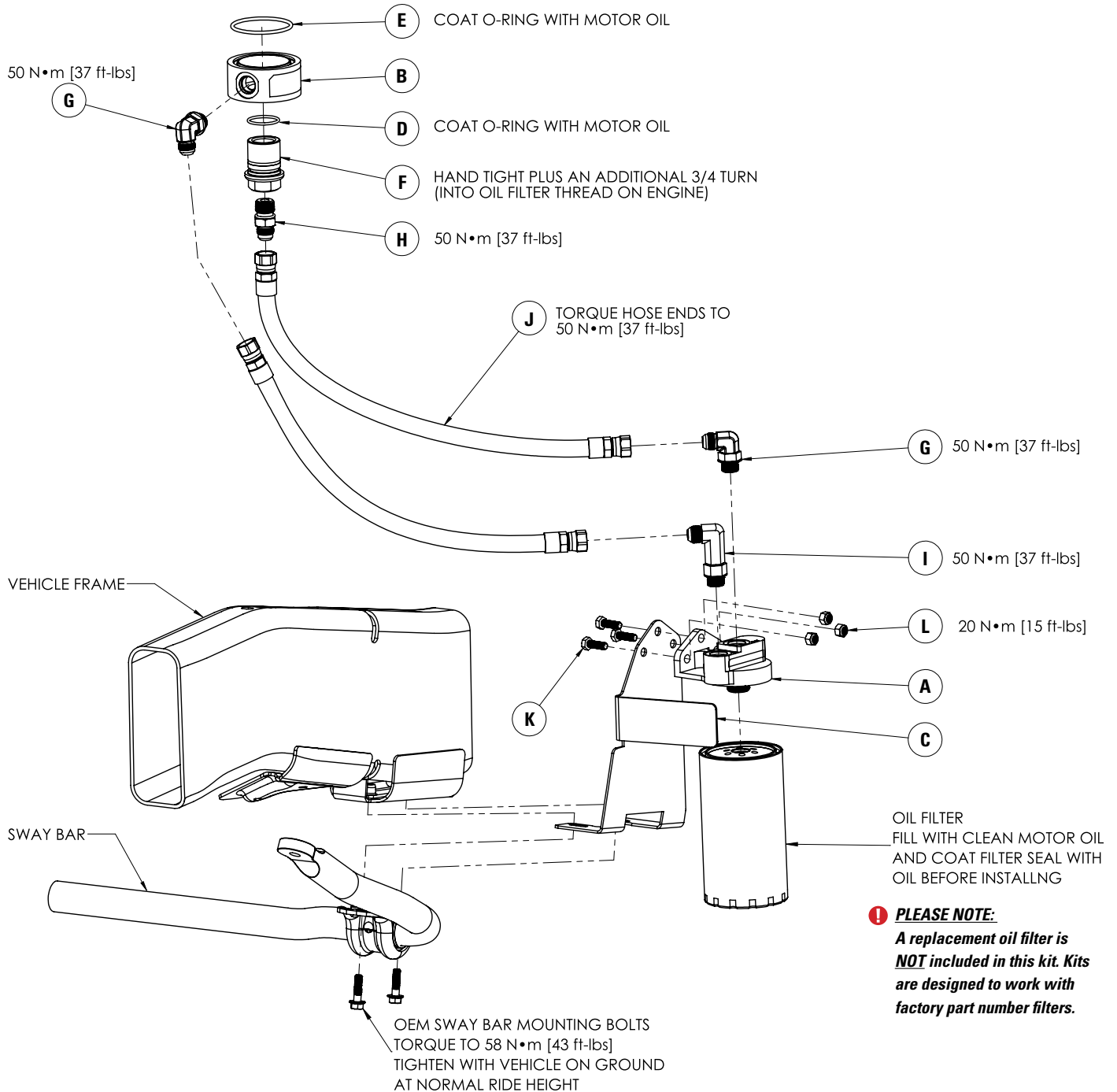

1 REMOVE THE EXISTING OIL FILTER

Remove the existing oil filter and recycle.

2 INSTALLING FITTINGS: REPLACEMENT FILTER HEAD

Locate the straight and 90° hydraulic fittings provided in the kit.

Use clean engine oil to apply a light coating to the O-rings on the fittings.

Ensure the locking nut on each fitting is fully threaded up the fitting body. Install the hydraulic fittings into the replacement filter head and filter nut until they cannot be rotated any further by hand.

Position the fitting in the 90° fitting downward (as shown in Figure 2 with a black arrow) by loosening up to one full turn maximum.

Tighten the lock nut on the 90° fitting to 50 N•m (37 ft-lbs).

Tighten the straight fitting to 50 N•m (37 ft-lbs).

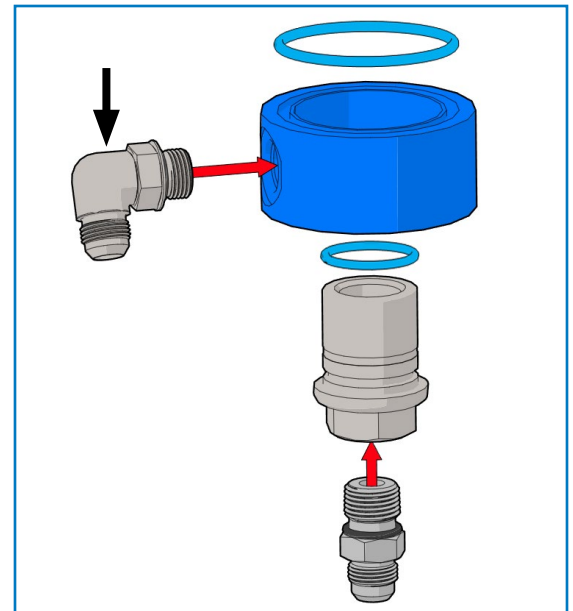

2

3 INSTALL RUBBER SEALS

Install the O-rings into the grooves on the replacement filter head and filter nut (as shown with the black arrows in Figure 3).

Put a light coat of clean engine oil on both seals and loosely install the assembly into the engine by turning the filter head retaining nut.



3

4 ADJUST FOR CLEARANCE

Install the replacement filter head in the oil filter mounting location on the engine.

Rotate the filter head assembly to attain maximum clearance for hose routing.

Tighten the filter head retaining nut as you would for a new filter installation.

5 ASSEMBLE BRACKET

Secure the remote filter head to the mounting bracket using the 5/16" fasteners provided (as shown in Figure 5).

Torque the screws to 20 N•m (15 ft-lbs).

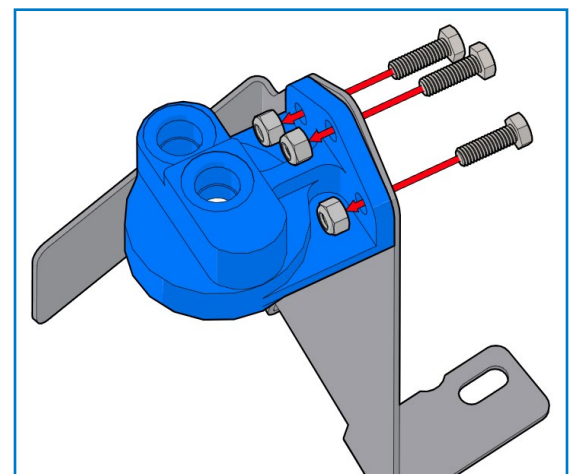

5

6 INSTALLING FITTINGS: REMOTE FILTER HEAD

Locate the 90° and extended 90° hydraulic fittings provided in the kit.

Use clean engine oil to apply a light coating to the O-rings on the fittings.

Ensure the locking nut on each fitting is fully threaded up the fitting body. Install the hydraulic fittings into the replacement filter head and filter nut until they cannot be rotated any further by hand.

Do not tighten the fittings yet to allow for adjustment.

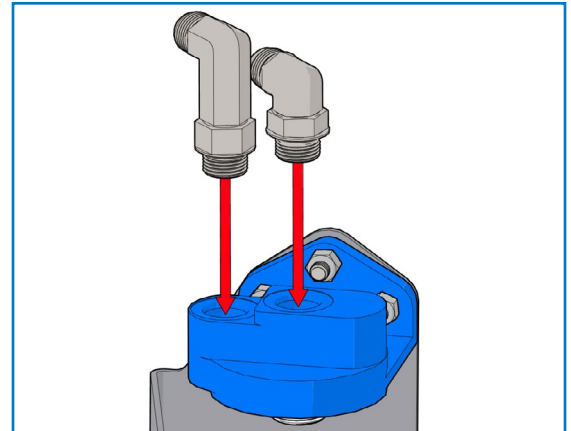

6

7 LOOSELY INSTALL MOUNTING BRACKET

Locate the two cap screws holding the sway bar in place on the passenger side.

Remove the screws and install the filter mounting bracket on the outside of the frame rail facing the wheel (reference Figures 7A & 7B).

Loosely reinstall the cap screws

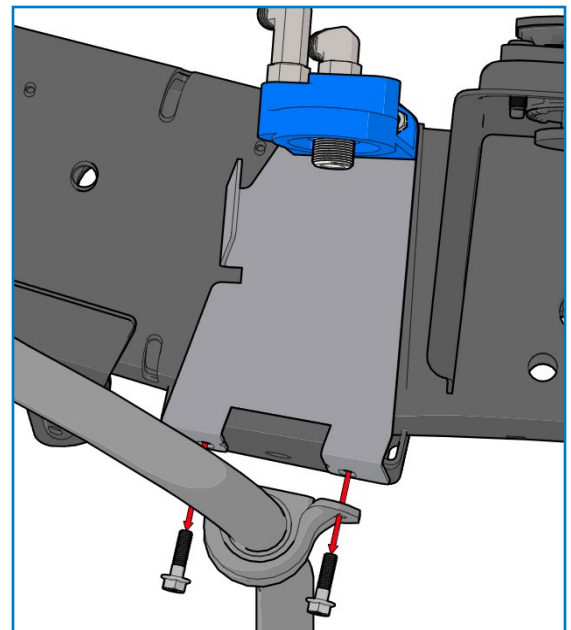

7A

8 ATTAIN HOSE CLEARANCE

Rotate the 90° hydraulic fittings to attain maximum clearance for hose routing.

Ensure that the fittings on the hoses have enough clearance to attach onto the fittings on the remote filter head

Remove the filter mounting bracket out from under the vehicle and tighten the lock nuts on both of the fittings to 50 N•m (37 ft-lbs).

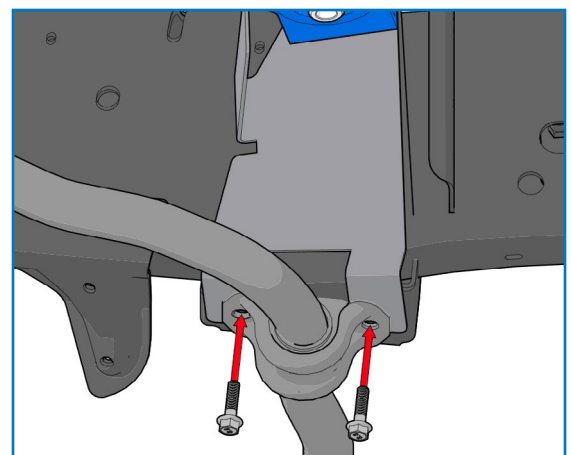

7B

9 HOSE ASSEMBLY

Locate the two hydraulic hoses provided in the kit and install one end of each hose onto the 90° fittings on the remote filter head.

Tighten both hose end fittings to 50 N•m (37 ft-lbs).

10 RE-INSTALL THE FILTER MOUNTING BRACKET

With the hoses still attached to the filter mounting head, roughly route the hoses into the vehicle and reinstall the filter mounting bracket into the vehicle.

With the vehicle on the ground at normal ride height torque the sway bar cap screws to 58 N•m (43 ft-lbs).

11 HOSE INSTALLATION

(Using Figure 11 as reference) Route the hoses from the remote filter head to the fittings on the replacement filter head.

- ❗ Connect the hose attached to the center fitting of the remote filter head to the center fitting on the replacement filter head. (as shown with the **grey** hose in Figure 11).
- ❗ Connect the hose attached to the outside fitting on the remote filter head to the outside fitting on the replacement filter head. (as shown with the **black** hose in Figure 11).

Tighten both hose end fittings to 50 N•m (37 ft-lbs).

Use the supplied tie straps to secure the hydraulic lines away from heat sources and moving parts.

12 INSTALL A NEW OIL FILTER

The remote filter head is designed for use with the factory part number oil filter.

Install a new oil filter into the remote filter head.

It is recommended to fill the new oil filter with clean engine oil prior to installation.

Double check all the fittings to ensure they are tightened adequately before moving on to the following step.

13 CHECK ENGINE OIL PRESSURE

Start the vehicle and allow to idle while watching the oil pressure gauge.

Ensure the engine oil pressure is in the NORMAL range.

14 CHECK FOR LEAKS

Once the engine oil pressure is in the normal range, check the entire system for oil leaks.

Congratulations!
You have completed the installation

.....

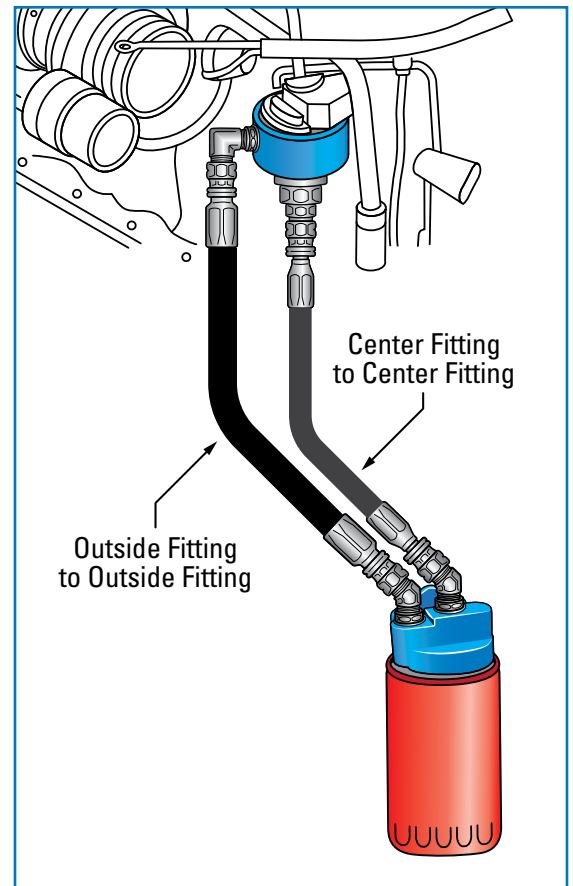

11