

INSTALL INSTRUCTIONS FOR 75-5189



BEFORE YOU START

Please read the entire product guide before proceeding.

Ensure all parts are present.

If you are missing any of the components, call our customer support at (909) 947-0015.

Do not work on your vehicle while the engine is hot.

Make sure the engine is turned off and the vehicle is in Park and the Parking Brake is set.

REQUIRED TOOLS

10mm, Socket and 1/4" Drive Wrench

3" Socket Extension

5/16" Nut Driver

Panel Popper

Phillips Screwdriver

Snips

Note: Approximate Install Time: 1 Hr

S&B FILTERS recommends that you keep your OE intake system in the event it is required in the future.

In order to maintain your warranty, all connections and components must be checked periodically for alignment and for proper tension on all connections. Failure to do so may void your warranty.

Use only S&B FILTERS cleaning and oil products to service your filter. Using any other brand oil and or cleaners on your S&B air filter may void your warranty

PERIODICALLY (DURING EACH ENGINE OIL CHANGE) CHECK THE FOLLOWING

- Intake Tube (11) and Filter (7) connections and Intake Box (1) fasteners making sure they are tight.
- All electrical connections and wire harnesses moved during the installation of the intake and make sure they are secure and away from any hot or moving components.
- Check for any signs of abrasion or wear and tear on the intake tube, box, filter, and electrical harnesses moved or near the intake and repair/replace as necessary.

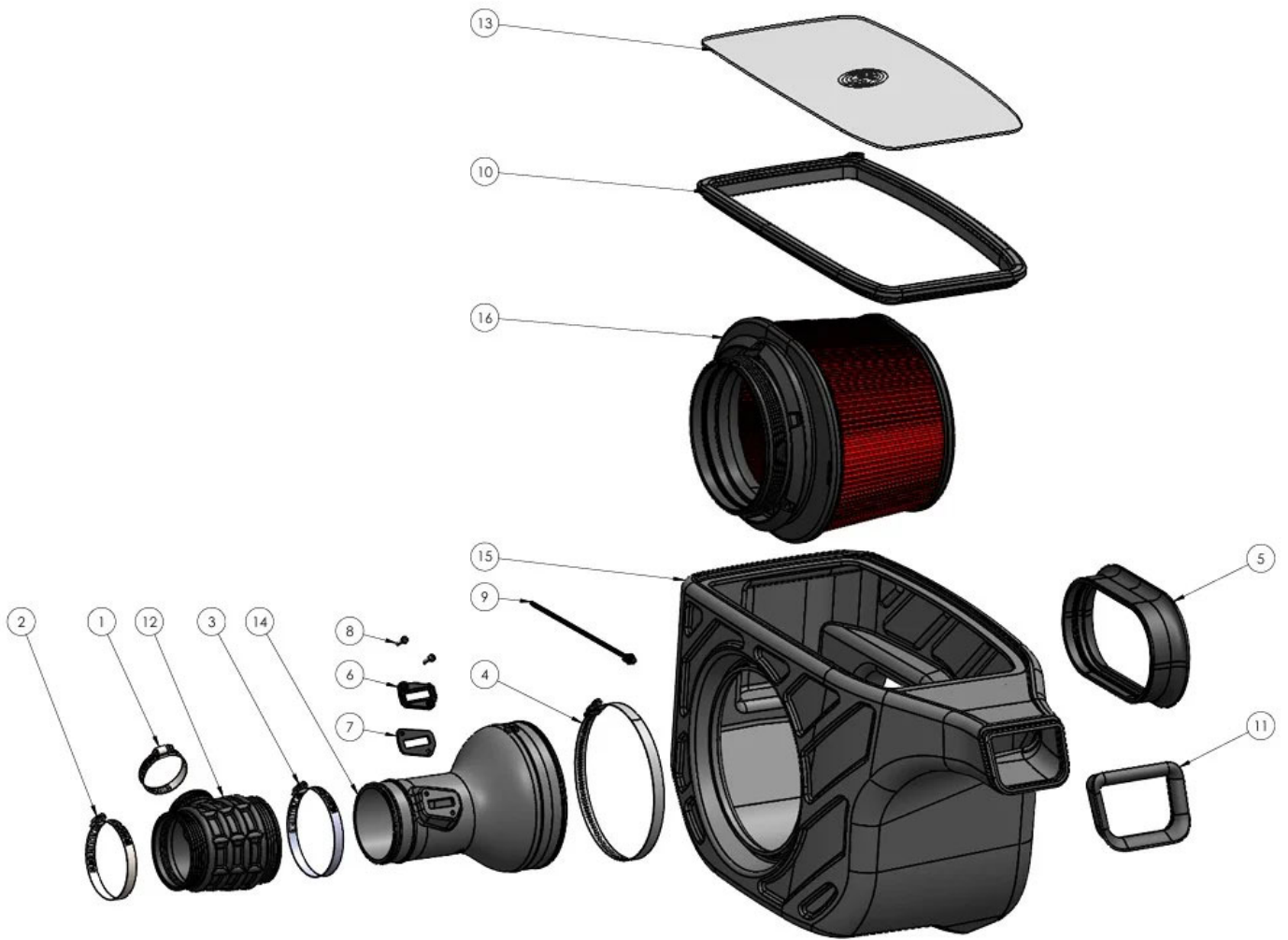

| ITEM NO. | PART NUMBER | DESCRIPTION | QTY. |
|----------|-------------|---|------|
| 1 | AG1002-00 | Hose Clamp, #28 | 1 |
| 2 | AG1007-00 | Hose Clamp, #52 | 1 |
| 3 | AG1008-00 | Hose Clamp, #60 | 1 |
| 4 | AG1025-00 | Hose Clamp, #128 | 1 |
| 5 | AI1810C-00 | Fender Seal, 75-5082, Silicone, Comp. Molded (6 cav.) | 1 |
| 6 | AI1822-00 | MAF Mount, Black | 1 |
| 7 | AI1823-00 | Gasket, for MAF mount - AI1822-00 | 1 |
| 8 | AI1837-00 | Screw, SEMS, Pan Head, Phillips, #8-32 X 3/4, SS | 2 |
| 9 | AI2154-00 | Push In Mount Cable Tie | 1 |
| 10 | AI2924C-00 | Scoop Seal, 75-5189, Silicone, Comp. Molded | 1 |
| 11 | AI2925C-00 | Scoop Seal, 75-5189, Silicone, Comp. Molded | 1 |
| 12 | AI2928C-00 | Wrapped Hose, Resonator Connector, 75-5189 | 1 |
| 13 | AI2929-00 | Clear lid | 1 |
| 14 | AL1441-00 | Intake Tube, 75-5189 | 1 |
| 15 | AL1441B-00 | Air Box, 75-5189 | 1 |
| 16 | KF-1098 | Replacement Filter for S&B Cold Air Intake Kit | 1 |

STEP 1

Disconnect the negative on the battery. Then with a 10mm socket or Phillips head screwdriver, remove the bolt holding the box to the body.



STEP 2

Lift up and pull out the engine cover.



STEP 3

Depress the button on the MAF sensor connector and remove from the MAF.

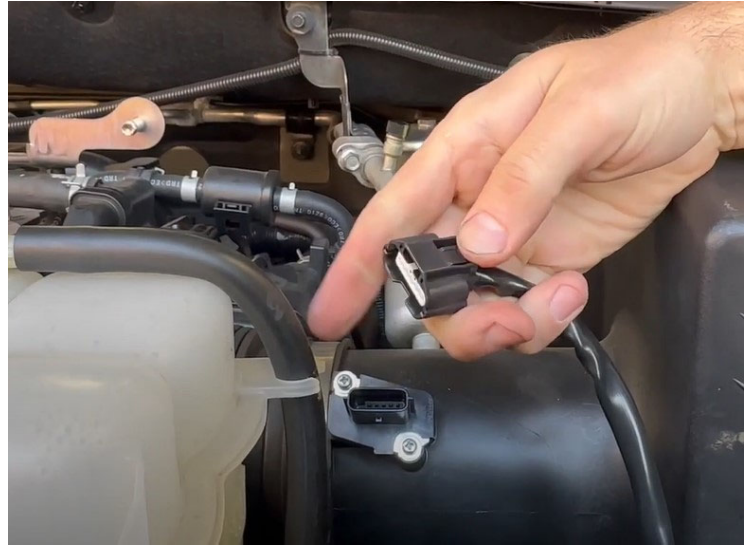

STEP 4

Remove the Christmas Tree pins that are holding the MAF sensor harness to the OEM air box with a panel popper.



STEP 5

Remove the hose clamp on the throttle body.

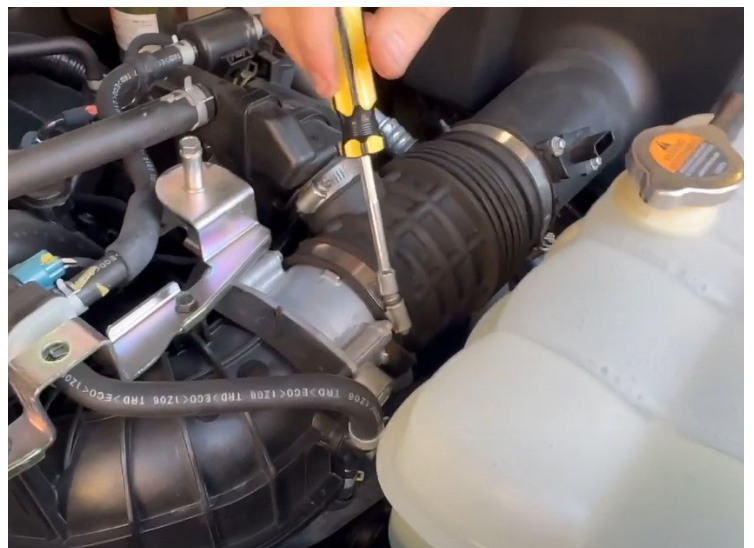

STEP 6

Remove the hose clamp holding the baffle to the intake tube and separate it from the tube



STEP 7

Remove the Christmas Tree pin holding the hose to the airbox.

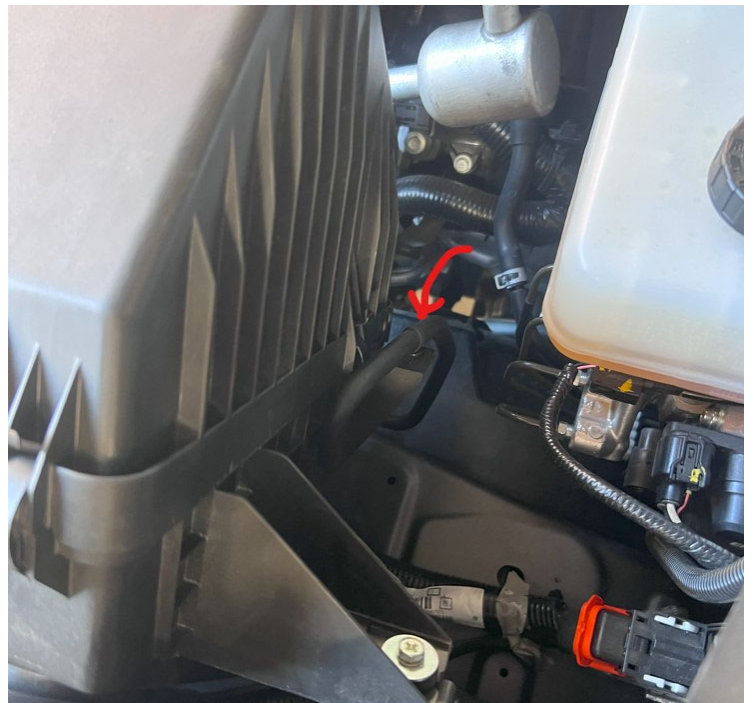

STEP 8

Lift the entire airbox/tube out of the vehicle.



STEP 9

With a panel popper, remove the pins holding the side inlet to the body.



STEP 10

Remove the stud with a 10mm socket.

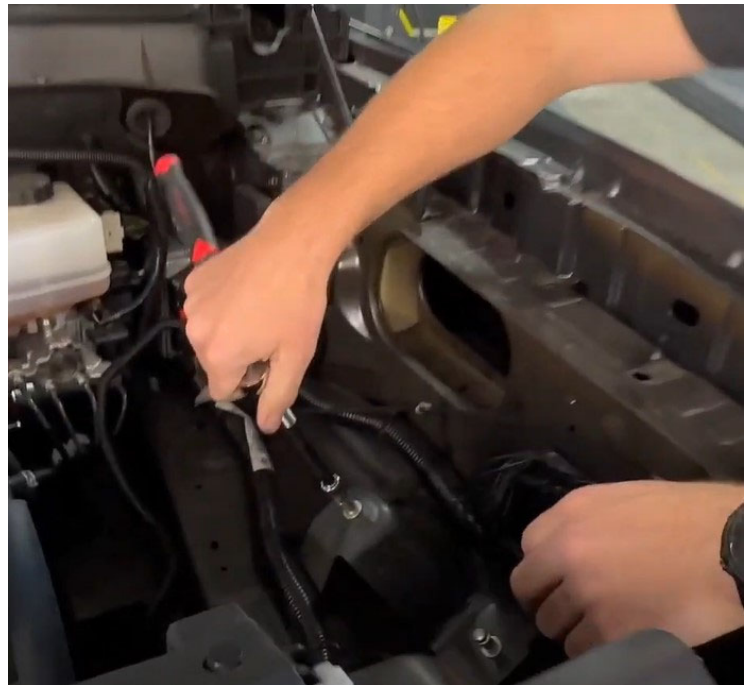

STEP 11

Install the IAT sensor grommet onto the S&B tube, make sure the tab lines up with the notch on the tube.

STEP 12

Install the S&B silicone side scoop onto the S&B airbox.



STEP 13

Install the front scoop onto the airbox.



STEP 14

Remove the metal bushing and gromet from the OEM airbox and install it onto the S&B airbox next to the side inlet.



STEP 15

Remove the large lower rubber grommet from the OEM airbox and install it onto the bottom of the S&B airbox.



STEP 16

Remove the MAF sensor from the OEM intake tube. Place the MAF sensor through S&B MAF gasket & plastic pad. Use the included S&B bolts to secure the sensor to the S&B intake tube.



STEP 17

Install the airbox into the truck. Line the box up with the stud that will press through the grommet then install the OEM bolt through the bushing/grommet inside the airbox.



STEP 18

Install the filter into the airbox then pull the flange of the filter through the hole in the airbox until the lip

around the filter "catches"
the opening of the airbox



STEP 19

Install the coupler onto the intake tube with the hose clamps loosely installed. Line up the tap on the tube with the cutout in the filter.

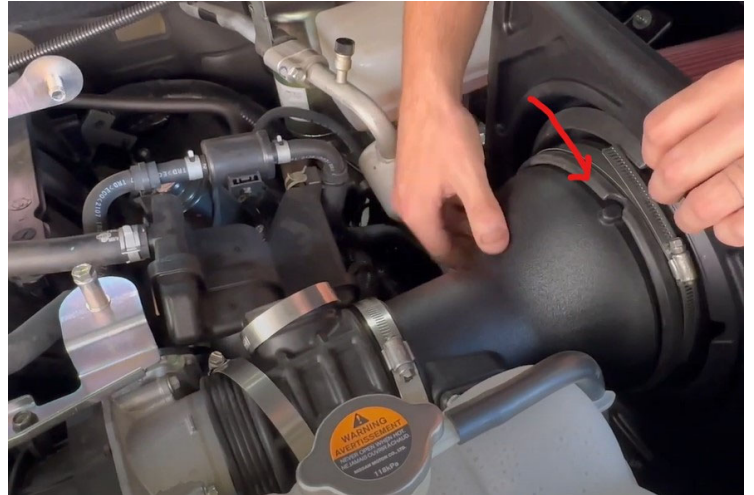

STEP 20

Install the baffle into the S&B coupler and tighten down all the hose clamps



STEP 21

Reinstall the MAF connector to the sensor.

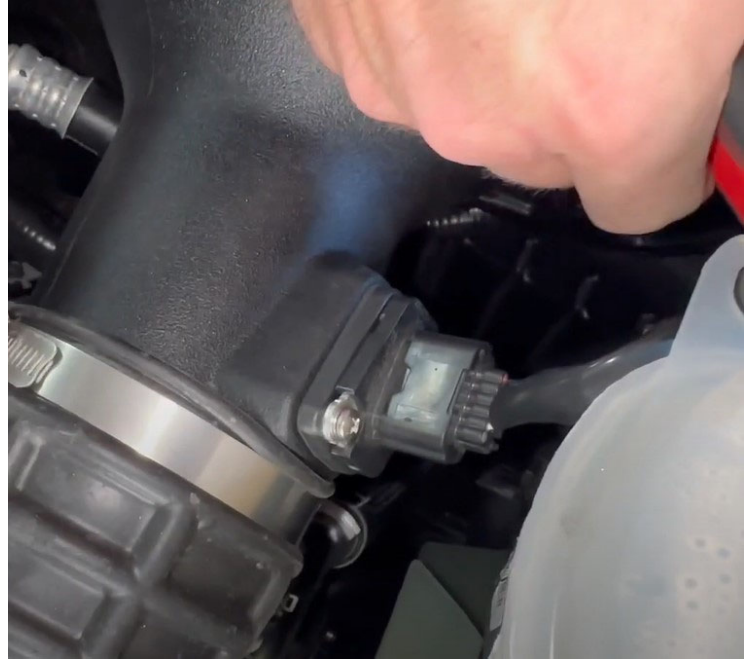

STEP 22

Cut off the OEM Christmas Tree and install the S&B Christmas Tree pin and install into the hole on the S&B airbox.

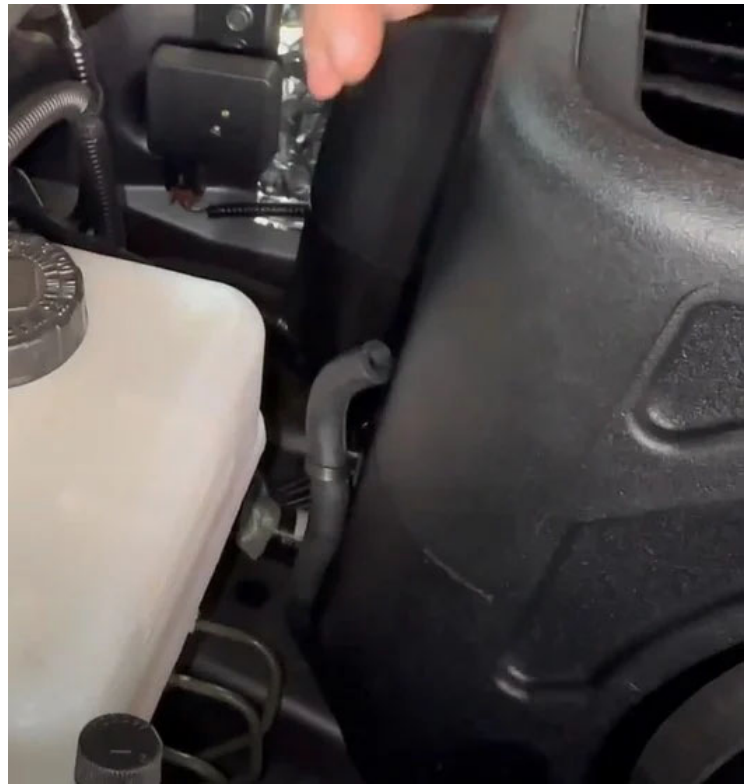

STEP 23

Remove the S&B lid from the protective film and install it into the S&B lid trim. Press the S&B snap in lid into the airbox.



STEP 24

Reinstall the engine cover and negative battery terminal. Check all connections.

