

# INTERCOOLER PIPE INSTALL INSTRUCTIONS FOR 83-2003

## BEFORE YOU START

### INTERCOOLER PIPE

**VEHICLE FITMENT:** 2011-2015 6.7L Powerstroke, Ford, F250/F350/F450

When removing any turbocharger air intake system components, make sure to cover any open ports to prevent any debris from entering the system. All components need to be inspected and cleaned (if necessary) prior to assembly and installation.

## REQUIRED TOOLS

- 7mm, 10mm, Socket and Wrench
- 11mm Deep Socket
- 10" Socket Extension or 4" + 6" Socket Extensions
- Panel Popper
- Pick
- Small Flat Blade Screwdriver
- Wire Cutters
- Torque Wrench, 75 in-lb setting

**Note:** Approximate Install Time: 1 Hr 00 Mins for Kit Installation.

- Charge air cooler T-Bolt Hose Clamps making sure they are tight and secure.
- All electrical connections and wire harnesses moved during the installation of the charge air cooler pipe/hose and making sure they are secure and away from any hot or moving components.
- Check for any signs of abrasion or wear and tear on the charge air cooler hose, coolant hoses, power steering reservoir, power steering hoses, and electrical harnesses near the charge air cooler pipe/hose and repair/replace as necessary.

ITEM NO.	PART NUMBER	DESCRIPTION	83-2003	83-2004
REF.	AL3002-00	Hot Side CAC Pipe Welded Assembly, 83-2003	1	-
	AL3003-00	Hot Side CAC Pipe Welded Assembly, 83-2004	-	1
	A12886-00	3x5.5 Hump, 4-Ply Aramid Wrapped Silicone Hose	1	1
	AG1042-00	T-Bolt Hose Clamp, Spring Loaded, 85.7-93.7mm	2	2
	A12796-00	3/16 width, Dash No. 332 Viton Fluoroelastomer O-Ring	1	1
	A12844-00	Spring Clip 83-2003/2004	1	1
A12843-00	Pipe Clip, 83-2003/ 2004	1	1	

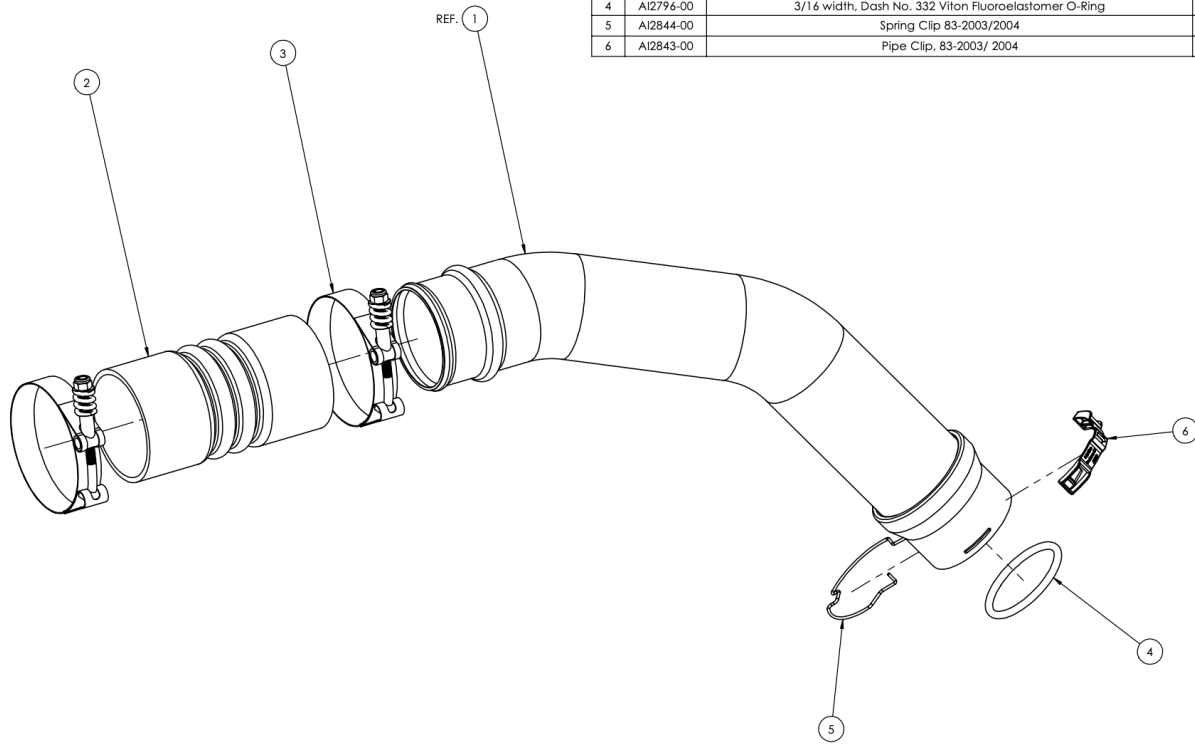

## STEP 1

Start by loosening the hose clamp on the intercooler side.



## STEP 2

Remove the clip on the top of the intercooler. To remove the clip, pry up on the clip and slide it to the top of the

retainer. Repeat for the bottom part of the clip.



### **STEP 3**

Remove the stock intercooler from the vehicle.



### **STEP 4**

Slide the provided O-ring into the O-ring groove inside the pipe.



### **STEP 5**

Install the S&B boot onto the intercooler with no hose clamp springs.



## STEP 6

Install the new clip onto the S&B intercooler.



## STEP 7

Slightly slide the S&B intercooler onto the collar at the turbo.



## STEP 8

Then connect the intercooler to the boot using a flathead screwdriver and clip the assembly into the turbo. Make sure you hear a click sound when it connects.



## STEP 9

Using an 11mm, remove the nuts on the springs in order to make them easier to install.



## STEP 10

Once both hose clamp springs are broken down, install them onto the boot.



# STEP 11

Once the hose clamp springs are installed on the boot, reinstall the springs and nuts then tighten down to 76 Inch-Pounds.



# CARB EO LABEL

Please affix the included CARB-approved EO label in an area under the hood. We recommend placing it on the radiator shroud, or the underside of the vehicle's hood near the S&B product.



## **Vehicle CARB EO** *Label Placement*

**Sample Label:**

	<b>FILTERS</b> <small>PERFORMANCE FILTERS AND INTAKES</small>
System Part #:	83-2003
CARB EO #:	D-590-XX
<small>S&amp;B Filters Inc., Fontana, CA, (800) 358-2639</small>	

**Locations:**

**Under Vehicle Hood**

**Radiator Shroud**  
(Preferred location)

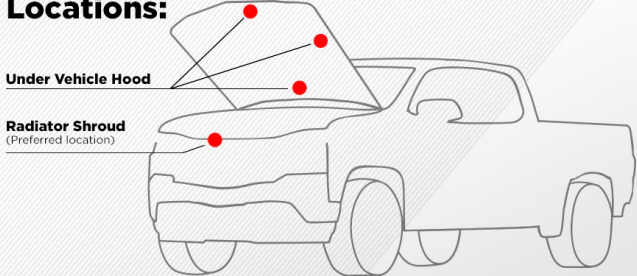
A line drawing of a vehicle from a front-three-quarter perspective. Red dots indicate the preferred locations for the CARB EO label: one on the radiator shroud and three on the underside of the hood. Lines connect these dots to the corresponding text labels.